

ANNEX I
SUMMARY OF PRODUCT CHARACTERISTICS

▼ This medicinal product is subject to additional monitoring. This will allow quick identification of new safety information. Healthcare professionals are asked to report any suspected adverse reactions. See section 4.8 for how to report adverse reactions.

1. NAME OF THE MEDICINAL PRODUCT

Lonquex 6 mg solution for injection

2. QUALITATIVE AND QUANTITATIVE COMPOSITION

Each pre-filled syringe contains 6 mg of lipegfilgrastim* in 0.6 ml solution.

Each ml of solution for injection contains 10 mg of lipegfilgrastim.

The active substance is a covalent conjugate of filgrastim** with methoxy polyethylene glycol (PEG) via a carbohydrate linker.

*This is based on protein content only. The concentration is 20.9 mg/ml (i.e. 12.6 mg per pre-filled syringe) if the PEG moiety and the carbohydrate linker are included.

**Filgrastim (recombinant methionyl human granulocyte-colony stimulating factor [G-CSF]) is produced in *Escherichia coli* cells by recombinant DNA technology.

The potency of this medicinal product should not be compared to the potency of another pegylated or non-pegylated protein of the same therapeutic class. For more information, see section 5.1.

Excipients with known effect

Each pre-filled syringe contains 30 mg sorbitol.

Each pre-filled syringe contains less than 1 mmol (23 mg) sodium.

For the full list of excipients, see section 6.1.

3. PHARMACEUTICAL FORM

Solution for injection (injection)

Clear, colourless solution

4. CLINICAL PARTICULARS

4.1 Therapeutic indications

Reduction in the duration of neutropenia and the incidence of febrile neutropenia in adult patients treated with cytotoxic chemotherapy for malignancy (with the exception of chronic myeloid leukaemia and myelodysplastic syndromes).

4.2 Posology and method of administration

Lonquex treatment should be initiated and supervised by physicians experienced in oncology or haematology.

Posology

One 6 mg dose of lipegfilgrastim (a single pre-filled syringe of Lonquex) is recommended for each chemotherapy cycle, given approximately 24 hours after cytotoxic chemotherapy.

Special populations

Elderly patients

In clinical studies with a limited number of elderly patients, there was no relevant age-related difference with regard to the efficacy or safety profiles of lipegfilgrastim. Therefore, no adjustment of the dose is necessary for elderly patients.

Patients with renal impairment

Currently available data are described in section 5.2, but no recommendation on a posology can be made.

Patients with hepatic impairment

Currently available data are described in section 5.2, but no recommendation on a posology can be made.

Paediatric population

The safety and efficacy of Lonquex in children and adolescents aged up to 17 years have not yet been established. Currently available data are described in sections 4.8, 5.1 and 5.2.

Method of administration

The solution is injected subcutaneously (SC). The injections should be given into the abdomen, upper arm or thigh.

For instructions on handling of the medicinal product before administration, see section 6.6.

Self-administration of Lonquex should only be performed by patients who are well motivated, adequately trained and have access to expert advice. The first injection of Lonquex should be performed under direct medical supervision.

4.3 Contraindications

Hypersensitivity to the active substance or to any of the excipients listed in section 6.1

4.4 Special warnings and precautions for use

General

The safety and efficacy of Lonquex have not been investigated in patients receiving high dose chemotherapy. Lonquex should not be used to increase the dose of cytotoxic chemotherapy beyond established dosage regimens.

In order to improve the traceability, the trade name and batch number of the administered medicinal product should be clearly recorded in the patient file.

Allergic reactions and immunogenicity

Patients who are hypersensitive to G-CSF or derivatives are also at risk of hypersensitivity reactions to lipegfilgrastim due to possible cross-reactivity. No lipegfilgrastim therapy should be commenced in these patients because of the risk of cross-reaction.

Most biological medicinal products elicit some level of anti-drug antibody response. This antibody response can, in some cases, lead to undesirable effects or loss of efficacy. If a patient fails to respond to treatment, the patient should undergo further evaluation.

If a serious allergic reaction occurs, appropriate therapy with close patient follow-up over several days should be administered.

Haematopoietic system

Treatment with lipegfilgrastim does not preclude thrombocytopenia and anaemia caused by myelosuppressive chemotherapy. Lipegfilgrastim may also cause reversible thrombocytopenia (see section 4.8). Regular monitoring of the platelet count and haematocrit is recommended. Special care should be taken when administering single or combination chemotherapeutic medicinal products that are known to cause severe thrombocytopenia.

Leukocytosis may occur (see section 4.8). No adverse events directly attributable to leukocytosis have been reported. Elevation in white blood cells (WBC) is consistent with the pharmacodynamic effects of lipegfilgrastim. A WBC count should be performed at regular intervals during therapy owing to the clinical effects of lipegfilgrastim and the potential for leukocytosis. If WBC counts exceed $50 \times 10^9/l$ after the expected nadir, lipegfilgrastim should be discontinued immediately.

Increased haematopoietic activity of the bone marrow in response to growth factor therapy has been associated with transient positive bone-imaging findings. This should be considered when interpreting bone-imaging results.

Patients with myeloid leukaemia or myelodysplastic syndromes

Granulocyte-colony stimulating factor can promote growth of myeloid cells and some non-myeloid cells *in vitro*.

The safety and efficacy of Lonquex have not been investigated in patients with chronic myeloid leukaemia, myelodysplastic syndromes or secondary acute myeloid leukaemia; it should therefore not be used in such patients. Particular care should be taken to distinguish the diagnosis of blast transformation of chronic myeloid leukaemia from acute myeloid leukaemia.

Splenic adverse reactions

Generally asymptomatic cases of splenomegaly have been reported after administration of lipegfilgrastim (see section 4.8) and infrequent cases of splenic rupture, including fatal cases, have been reported after administration of G-CSF or derivatives (see section 4.8). Spleen size should therefore be carefully monitored (e.g. clinical examination, ultrasound). A diagnosis of splenic rupture should be considered in patients reporting left upper abdominal pain or shoulder tip pain.

Pulmonary adverse reactions

Pulmonary adverse reactions, in particular interstitial pneumonia, have been reported after administration of lipegfilgrastim (see section 4.8). Patients with a recent history of pulmonary infiltrates or pneumonia may be at higher risk.

The onset of pulmonary symptoms such as cough, fever and dyspnoea in association with radiological signs of pulmonary infiltrates and deterioration in pulmonary function together with an increased neutrophil count may be preliminary signs of Acute Respiratory Distress Syndrome (ARDS) (see section 4.8). In such circumstances Lonquex should be discontinued at the discretion of the physician and appropriate treatment given.

Vascular adverse reactions

Capillary leak syndrome has been reported after administration of G-CSF or derivatives and is characterised by hypotension, hypoalbuminaemia, oedema and haemoconcentration. Patients who develop symptoms of capillary leak syndrome should be closely monitored and receive standard symptomatic treatment, which may include a need for intensive care (see section 4.8).

Patients with sickle cell anaemia

Sickle cell crisis has been associated with the use of G-CSF or derivatives in patients with sickle cell anaemia (see section 4.8). Physicians should therefore exercise caution when administering Lonquex in patients with sickle cell anaemia, monitor appropriate clinical parameters and laboratory results and be attentive to the possible association of lipegfilgrastim with splenic enlargement and vaso-occlusive crisis.

Hypokalaemia

Hypokalaemia may occur (see section 4.8). For patients with increased risk on hypokalaemia due to underlying disease or co-medications, it is recommended to monitor the serum potassium level carefully and to substitute potassium if necessary.

Excipients with known effect

This medicinal product contains sorbitol. Patients with rare hereditary problems of fructose intolerance should not use this medicinal product.

This medicinal product contains less than 1 mmol sodium (23 mg) per pre-filled syringe, i.e. essentially 'sodium-free'.

4.5 Interaction with other medicinal products and other forms of interaction

Due to the potential sensitivity of rapidly dividing myeloid cells to cytotoxic chemotherapy, Lonquex should be administered approximately 24 hours after administration of cytotoxic chemotherapy. Concomitant use of lipegfilgrastim with any chemotherapeutic medicinal product has not been evaluated in patients. In animal models, concomitant administration of G-CSF and 5-fluorouracil (5-FU) or other antimetabolites has been shown to potentiate myelosuppression.

The safety and efficacy of Lonquex have not been evaluated in patients receiving chemotherapy associated with delayed myelosuppression, e.g. nitrosoureas.

The potential for interaction with lithium, which also promotes the release of neutrophils, has not been specifically investigated. There is no evidence that such an interaction would be harmful.

4.6 Fertility, pregnancy and lactation

Pregnancy

There are very limited data (less than 300 pregnancy outcomes) on the use of lipegfilgrastim in pregnant women. Animal studies have shown reproductive toxicity (see section 5.3). As a precautionary measure, it is preferable to avoid the use of Lonquex during pregnancy.

Breast-feeding

It is unknown whether lipegfilgrastim/metabolites are excreted in human milk. A risk to the suckling child cannot be excluded. Breast-feeding should be discontinued during treatment with Lonquex.

Fertility

No data are available. Animal studies with G-CSF and derivatives do not indicate harmful effects with respect to fertility (see section 5.3).

4.7 Effects on ability to drive and use machines

Lonquex has no or negligible influence on the ability to drive and use machines.

4.8 Undesirable effects

Summary of the safety profile

The most frequent undesirable effects are musculoskeletal pains. Musculoskeletal pains are generally of mild to moderate severity, transient and can be controlled in most patients with standard analgesics.

Capillary leak syndrome, which can be life-threatening if treatment is delayed, has been reported mostly in cancer patients undergoing chemotherapy after administration of G-CSF or derivatives (see section 4.4 and subsection "Description of selected adverse reactions" of section 4.8).

Tabulated list of adverse reactions

The safety of lipegfilgrastim has been evaluated based on results from clinical studies including 506 patients and 76 healthy volunteers treated at least once with lipegfilgrastim.

The adverse reactions listed below in table 1 are classified according to System organ class. Frequency groupings are defined according to the following convention:

Very common: $\geq 1/10$

Common: $\geq 1/100$ to $< 1/10$

Uncommon: $\geq 1/1,000$ to $< 1/100$

Rare: $\geq 1/10,000$ to $< 1/1,000$

Very rare: $< 1/10,000$

Not known: cannot be estimated from the available data.

Within each frequency grouping, undesirable effects are presented in order of decreasing seriousness.

Table 1: Adverse reactions

<u>System organ class</u>	<u>Frequency</u>	<u>Adverse reaction</u>
<i>Blood and lymphatic system disorders</i>	Common	Thrombocytopenia*
	Uncommon	Leukocytosis*, Splenomegaly*
<i>Immune system disorders</i>	Uncommon	Hypersensitivity reactions*
<i>Metabolism and nutrition disorders</i>	Common	Hypokalaemia*
<i>Nervous system disorders</i>	Common	Headache
<i>Vascular disorders</i>	Not known	Capillary leak syndrome*
<i>Respiratory, thoracic and mediastinal disorders</i>	Uncommon	Pulmonary adverse reactions*
<i>Skin and subcutaneous tissue disorders</i>	Common	Skin reactions*
	Uncommon	Injection site reactions*
<i>Musculoskeletal and connective tissue disorders</i>	Very common	Musculoskeletal pains*
<i>General disorders and administration site conditions</i>	Common	Chest pain
<i>Investigations</i>	Uncommon	Blood alkaline phosphatase increased*, Blood lactate dehydrogenase increased*

*See subsection "Description of selected adverse reactions" below

Description of selected adverse reactions

Thrombocytopenia and leukocytosis have been reported (see section 4.4).

Splenomegaly, generally asymptomatic, has been reported (see section 4.4).

Hypersensitivity reactions such as allergic skin reactions, urticaria, angioedema and serious allergic reactions may occur.

Hypokalaemia has been reported (see section 4.4).

Pulmonary adverse reactions, in particular interstitial pneumonia, have been reported (see section 4.4). These pulmonary adverse reactions may also include pulmonary oedema, pulmonary infiltrates, pulmonary fibrosis, respiratory failure or ARDS (see section 4.4).

Skin reactions such as erythema and rash may occur.

Injection site reactions such as injection site induration and injection site pain may occur.

The most frequent adverse reactions are musculoskeletal pains such as bone pain and myalgia. Musculoskeletal pains are generally of mild to moderate severity, transient and can be controlled in most patients with standard analgesics.

Reversible, mild to moderate elevations in alkaline phosphatase and lactate dehydrogenase may occur, with no associated clinical effects. Elevations in alkaline phosphatase and lactate dehydrogenase most likely originate from the increase in neutrophils.

Certain adverse reactions have not yet been observed with lipegfilgrastim, but are generally accepted as being attributable to G-CSF and derivatives:

Blood and lymphatic system disorders

- Splenic rupture including some fatal cases (see section 4.4)
- Sickle cell crisis in patients with sickle cell anaemia (see section 4.4)

Vascular disorders

- Capillary leak syndrome
Cases of capillary leak syndrome have been reported in postmarketing experience after administration of G-CSF or derivatives. These have generally occurred in patients suffering from advanced malignant diseases, having sepsis, taking multiple chemotherapy medications or undergoing apheresis (see section 4.4).

Skin and subcutaneous tissue disorders

- Acute febrile neutrophilic dermatosis (Sweet's syndrome)
- Cutaneous vasculitis

Paediatric population

The experience in children is limited to a single-dose phase 1 study in 21 paediatric patients aged 2 to <18 years (see section 5.1), which did not indicate a difference in the safety profile of lipegfilgrastim in children compared to that in adults. Treatment-related adverse events were back pain, bone pain and increased neutrophil count (1 event each).

Reporting of suspected adverse reactions

Reporting suspected adverse reactions after authorisation of the medicinal product is important. It allows continued monitoring of the benefit/risk balance of the medicinal product. Healthcare professionals are asked to report any suspected adverse reactions via the national reporting system listed in Appendix V.

4.9 Overdose

There is no experience with overdose of lipegfilgrastim. In the case of overdose, WBC and platelet count should be performed regularly and spleen size should be carefully monitored (e.g. clinical examination, ultrasound).

5. PHARMACOLOGICAL PROPERTIES

5.1 Pharmacodynamic properties

Pharmacotherapeutic group: Immunostimulants, Colony stimulating factors, ATC code: L03AA14

Mechanism of action

Lipegfilgrastim is a covalent conjugate of filgrastim with a single methoxy polyethylene glycol (PEG) molecule via a carbohydrate linker consisting of glycine, *N*-acetylneuraminic acid and *N*-acetylgalactosamine. The average molecular mass is approximately 39 kDa of which the protein moiety constitutes approximately 48 %. Human G-CSF is a glycoprotein that regulates the production and release of functional neutrophils from the bone marrow. Filgrastim is an un-glycosylated

recombinant methionyl human G-CSF. Lipegfilgrastim is a sustained duration form of filgrastim due to decreased renal clearance. Lipegfilgrastim binds to human the G-CSF receptor like filgrastim and pegfilgrastim.

Pharmacodynamic effects

Lipegfilgrastim and filgrastim induced a marked increase in peripheral blood neutrophil counts within 24 hours, with minor increases in monocytes and/or lymphocytes. These results suggest that the G-CSF moiety of lipegfilgrastim confers the expected activity of this growth factor: stimulation of proliferation of haematopoietic progenitor cells, differentiation into mature cells and release into the peripheral blood. This effect includes not only the neutrophil lineage but extends to other single lineage and multilineage progenitors and pluripotent haematopoietic stem cells. G-CSF also increases the antibacterial activities of neutrophils including the phagocytosis.

Clinical efficacy and safety

Once-per-cycle dosing of lipegfilgrastim was investigated in two pivotal randomised, double-blind clinical studies in patients undergoing myelosuppressive chemotherapy.

The first pivotal (phase III) clinical study XM22-03 was an active-controlled study in 202 patients with stage II-IV breast cancer receiving up to 4 cycles of chemotherapy consisting of doxorubicin and docetaxel. Patients were randomised 1:1 to receive 6 mg lipegfilgrastim or 6 mg pegfilgrastim. The study showed non-inferiority of 6 mg lipegfilgrastim to 6 mg pegfilgrastim for the primary endpoint, duration of severe neutropenia (DSN) in the first cycle of chemotherapy (see table 2).

Table 2: DSN, severe neutropenia (SN) and febrile neutropenia (FN) in cycle 1 of study XM22-03 (ITT)

	Pegfilgrastim 6 mg (n = 101)	Lipegfilgrastim 6 mg (n = 101)
<u>DSN</u>		
Mean ± SD (d)	0.9 ± 0.9	0.7 ± 1.0
Δ LS mean	-0.186	
95 % CI	-0.461 to 0.089	
<u>SN</u>		
Incidence (%)	51.5	43.6
<u>FN</u>		
Incidence (%)	3.0	1.0
ITT = Intent-to-treat population (all randomised patients) SD = standard deviation d = days CI = confidence interval Δ LS mean (least square mean difference lipegfilgrastim – pegfilgrastim) and CI out of multivariate Poisson regression analysis		

The second pivotal (phase III) clinical study XM22-04 was a placebo-controlled study in 375 patients with non-small cell lung cancer receiving up to 4 cycles of chemotherapy consisting of cisplatin and etoposide. Patients were randomised 2:1 to receive either 6 mg lipegfilgrastim or placebo. The results of the study are presented in table 3. When the main study was finalised, the incidence of death was 7.2 % (placebo) and 12.5 % (6 mg lipegfilgrastim) although after the 360-day follow-up period the overall incidence of death was similar between placebo and lipegfilgrastim (44.8 % and 44.0 %; safety population).

Table 3: DSN, SN and FN in cycle 1 of study XM22-04 (ITT)

	Placebo (n = 125)	Lipegfilgrastim 6 mg (n = 250)
FN		
Incidence (%)	5.6	2.4
95 % CI	0.121 to 1.260	
p-value	0.1151	
DSN		
Mean ± SD (d)	2.3 ± 2.5	0.6 ± 1.1
Δ LS mean	-1.661	
95 % CI	-2.089 to -1.232	
p-value	< 0.0001	
SN		
Incidence (%)	59.2	32.1
Odds ratio	0.325	
95 % CI	0.206 to 0.512	
p-value	< 0.0001	
Δ LS mean (least square mean difference lipegfilgrastim – placebo), CI and p-value out of multivariate Poisson regression analysis		
Odds ratio (lipegfilgrastim / placebo), CI and p-value out of multivariate logistic regression analysis		

Immunogenicity

An analysis of anti-drug antibodies of 579 patients and healthy volunteers treated with lipegfilgrastim, 188 patients and healthy volunteers treated with pegfilgrastim and 121 patients treated with placebo was performed. Drug-specific antibodies emerging after start of treatment were detected in 0.86 % of the subjects receiving lipegfilgrastim, in 1.06 % of the subjects receiving pegfilgrastim and in 1.65 % of the subjects receiving placebo. No neutralising antibodies against lipegfilgrastim were observed.

Paediatric population

The European Medicines Agency has deferred the obligation to submit the results of studies with Lonquex in all subsets of the paediatric population in the treatment of chemotherapy-induced neutropenia and prevention of chemotherapy-induced febrile neutropenia (see section 4.2 for information on paediatric use). In a phase 1 study of 21 children aged between 2 and 16 years with Ewing family of tumours or rhabdomyosarcoma, lipegfilgrastim was administered as a single subcutaneous dose of 100 µg/kg (up to a maximum of 6 mg, which is the fixed dose for adults) 24 hours after the end of the last chemotherapy treatment in week 1 of the regimen. The incidence of FN varied according to age (from 14.3 % to 71.4 %), with the highest frequency in the oldest age group. The use of three different chemotherapy regimens, with varying myelosuppressive effects and age distributions, complicated the comparison of efficacy across age groups. See section 4.2.

5.2 Pharmacokinetic properties

General

Healthy volunteers

In 3 studies (XM22-01, XM22-05, XM22-06) in healthy volunteers, the maximum blood concentration was reached after a median of 30 to 36 hours and the average terminal half-life ranged from approximately 32 to 62 hours after a single subcutaneous injection of 6 mg lipegfilgrastim.

After subcutaneous injection of 6 mg lipegfilgrastim at three different sites (upper arm, abdomen and thigh) in healthy volunteers, the bioavailability (peak concentration and area under the curve [AUC]) was lower after subcutaneous injection in the thigh compared to subcutaneous injection in the abdomen and in the upper arm. In this limited study XM22-06, bioavailability of lipegfilgrastim and observed differences among the injection sites were higher in male subjects compared to female subjects. Nevertheless, pharmacodynamic effects were similar and independent from gender and injection site.

Metabolism

Lipegfilgrastim is metabolised via intra- or extracellular degradation by proteolytic enzymes. Lipegfilgrastim is internalised by neutrophils (non-linear process), then degraded within the cell by endogenous proteolytic enzymes. The linear pathway is likely due to extracellular protein degradation by neutrophil elastase and other plasma proteases.

Drug interactions

In vitro data indicate that lipegfilgrastim has little or no direct or immune system-mediated effects on CYP1A2, CYP2B6, CYP2C8, CYP2C9, CYP2C19, and CYP3A4/5 activity. Therefore, lipegfilgrastim is not likely to affect metabolism via human cytochrome P450 enzymes.

Special populations

Cancer patients

In 2 studies (XM22-02 and XM22-03) in patients with breast cancer receiving chemotherapy consisting of doxorubicin and docetaxel, mean maximum blood concentrations of 227 and 262 ng/ml were reached after median times to maximum concentration (t_{max}) of 44 and 48 hours. The mean terminal half-lives were approximately 29 and 31 hours after a single subcutaneous injection of 6 mg lipegfilgrastim during the first cycle of chemotherapy. After a single subcutaneous injection of 6 mg lipegfilgrastim during the fourth cycle, the maximum blood concentrations were lower than observed in the first cycle (mean values 77 and 111 ng/ml) and were reached after median t_{max} of 8 hours. The mean terminal half-lives in the fourth cycle were approximately 39 and 42 hours.

In a study (XM22-04) in patients with non-small cell lung cancer receiving chemotherapy consisting of cisplatin and etoposide, the mean maximum blood concentration of 317 ng/ml was reached after a median t_{max} of 24 hours and the mean terminal half-life was approximately 28 hours after a single subcutaneous injection of 6 mg lipegfilgrastim during the first cycle of chemotherapy. After a single subcutaneous injection of 6 mg lipegfilgrastim during the fourth cycle, the mean maximum blood concentration of 149 ng/ml was reached after a median t_{max} of 8 hours and the mean terminal half-life was approximately 34 hours.

Lipegfilgrastim appears to be mainly eliminated by neutrophil-mediated clearance, which becomes saturated at higher doses. Consistent with a self-regulating clearance mechanism, the serum concentration of lipegfilgrastim declines slowly during the chemotherapy-induced transient neutrophil nadir and rapidly at the following onset of neutrophil recovery (see figure 1).

Figure 1: Profile of median serum concentration of lipegfilgrastim and median ANC in chemotherapy-treated patients after a single 6 mg injection of lipegfilgrastim

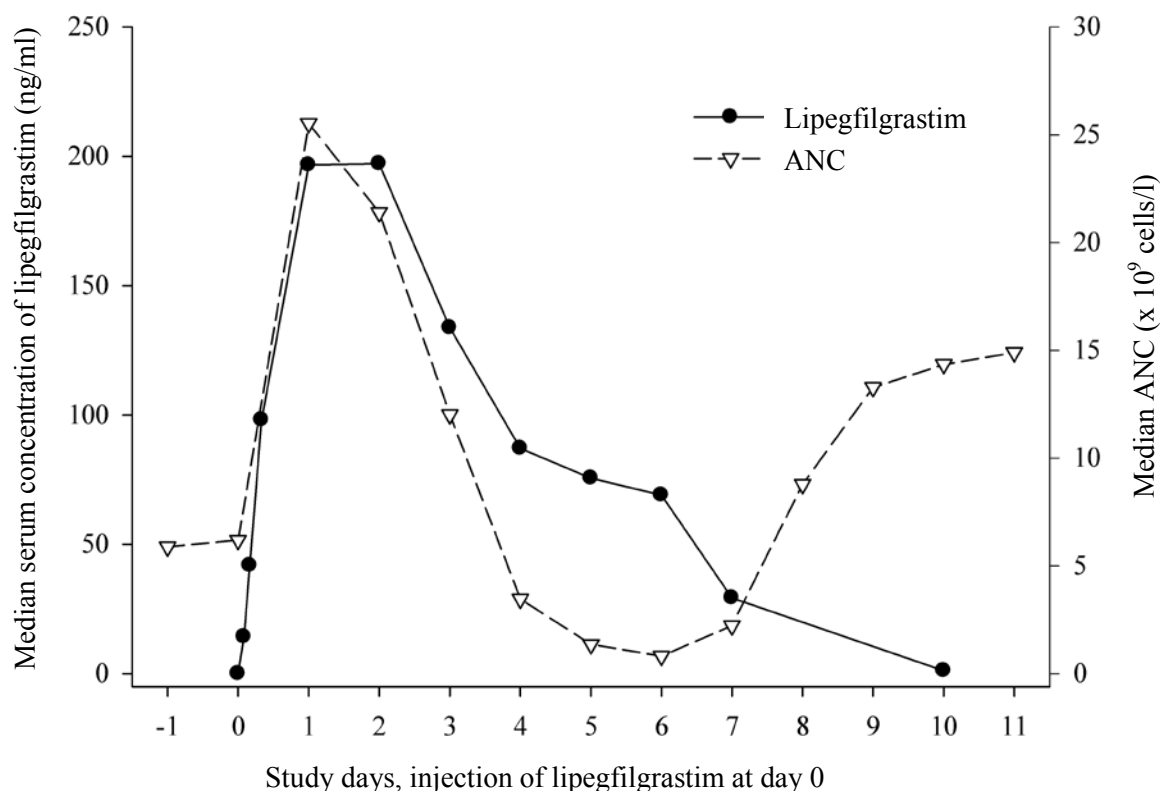

Patients with renal or hepatic impairment

Due to the neutrophil-mediated clearance mechanism, the pharmacokinetics of lipegfilgrastim is not expected to be affected by renal or hepatic impairment.

Elderly patients

Limited patient data indicate that the pharmacokinetics of lipegfilgrastim in elderly patients (65 - 74 years) is similar to that in younger patients. No pharmacokinetic data are available in patients ≥ 75 years.

Paediatric population

In a phase 1 study (see section 5.1), using a 10 mg/ml solution for subcutaneous injection specifically developed for the paediatric studies, the mean maximum blood concentrations (C_{max}) were 243 ng/ml in the 2 to <6-year group, 255 ng/ml in the 6 to <12-year group and 224 ng/ml in the 12 to <18-year group after a single subcutaneous injection of 100 μ g/kg (maximum 6 mg) lipegfilgrastim with the first cycle of chemotherapy. The maximum blood concentrations were reached after a median time (t_{max}) of 23.9 hours, 30.0 hours and 95.8 hours, respectively. See section 4.2.

Overweight patients

A trend towards a decrease in lipegfilgrastim exposure was observed with increase in weight. This may result in lowered pharmacodynamic responses in heavy patients (> 95 kg). Consequent decrease in efficacy in these patients cannot be excluded on current data.

5.3 Preclinical safety data

Non-clinical data reveal no special hazard for humans based on conventional studies of safety pharmacology, single and repeated dose toxicity and local tolerance.

In a study of toxicity to reproduction and development in rabbits, an increased incidence of post-implantation loss and abortion has been observed at high doses of lipegfilgrastim, likely owing to

an exaggerated pharmacodynamic effect specific for rabbits. There is no evidence that lipegfilgrastim is teratogenic. These findings are consistent with results from G-CSF and derivatives. Published information on G-CSF and derivatives reveal no evidence of adverse effects on fertility and embryo-foetal development in rats or pre-/postnatal effects other than those related to maternal toxicity as well. There is evidence that filgrastim and pegfilgrastim may be transported at low levels over the placenta in rats, although no information is available for lipegfilgrastim. The relevance of these findings for humans is not known.

6. PHARMACEUTICAL PARTICULARS

6.1 List of excipients

Acetic acid, glacial
Sodium hydroxide (for pH adjustment)
Sorbitol (E420)
Polysorbate 20
Water for injections

6.2 Incompatibilities

In the absence of compatibility studies, this medicinal product must not be mixed with other medicinal products.

6.3 Shelf life

2 years

6.4 Special precautions for storage

Store in a refrigerator (2 °C – 8 °C).

Do not freeze.

Keep the pre-filled syringe in the outer carton in order to protect from light.

Lonquex may be removed from the refrigerator and stored below 25 °C for a maximum single period of up to 3 days. Once removed from the refrigerator, the medicinal product must be used within this period or disposed of.

6.5 Nature and contents of container

0.6 ml of solution in a pre-filled syringe (type I glass) with a plunger stopper [poly(ethylene-co-tetrafluoroethylene)-coated bromobutyl rubber] and a fixed injection needle (stainless steel, 29G [0.34 mm] or 27G [0.4 mm] x 0.5 inch [12.7 mm]).

Pack sizes of 1 pre-filled syringe with or without safety device (which prevents needle stick injury and re-use).

Not all pack sizes may be marketed.

6.6 Special precautions for disposal and other handling

The solution should be visually inspected before use. Only clear, colourless solutions without particles should be used.

The solution should be allowed to reach a comfortable temperature (15 °C - 25 °C) for injection.

Vigorous shaking should be avoided. Excessive shaking may aggregate lipegfilgrastim, rendering it biologically inactive.

Lonquex does not contain any preservative. In view of the possible risk of microbial contamination, Lonquex syringes are for single use only.

Any unused medicinal product or waste material should be disposed of in accordance with local requirements.

7. MARKETING AUTHORISATION HOLDER

UAB "Sicor Biotech"
Molėtų pl. 5
LT-08409 Vilnius
Lithuania

8. MARKETING AUTHORISATION NUMBER(S)

EU/1/13/856/001
EU/1/13/856/002

9. DATE OF FIRST AUTHORISATION/RENEWAL OF THE AUTHORISATION

Date of first authorisation: 25 July 2013.

10. DATE OF REVISION OF THE TEXT

Detailed information on this medicinal product is available on the website of the European Medicines Agency <http://www.ema.europa.eu>.

ANNEX II

- A. MANUFACTURER OF THE BIOLOGICAL ACTIVE
SUBSTANCE AND MANUFACTURERS RESPONSIBLE
FOR BATCH RELEASE**
- B. CONDITIONS OR RESTRICTIONS REGARDING SUPPLY
AND USE**
- C. OTHER CONDITIONS AND REQUIREMENTS OF THE
MARKETING AUTHORISATION**
- D. CONDITIONS OR RESTRICTIONS WITH REGARD TO
THE SAFE AND EFFECTIVE USE OF THE MEDICINAL
PRODUCT**

A. MANUFACTURER OF THE BIOLOGICAL ACTIVE SUBSTANCE AND MANUFACTURERS RESPONSIBLE FOR BATCH RELEASE

Name and address of the manufacturer of the biological active substance

Teva Biotech GmbH
Dornierstraße 10
D-89079 Ulm
Germany

Name and address of the manufacturers responsible for batch release

Teva Biotech GmbH
Dornierstraße 10
D-89079 Ulm
Germany

Teva Pharmaceuticals Europe B.V.
Swensweg 5
NL-2031 GA Haarlem
The Netherlands

The printed package leaflet of the medicinal product must state the name and address of the manufacturer responsible for the release of the concerned batch.

B. CONDITIONS OR RESTRICTIONS REGARDING SUPPLY AND USE

Medicinal product subject to restricted medical prescription (see Annex I: Summary of Product Characteristics, section 4.2).

C. OTHER CONDITIONS AND REQUIREMENTS OF THE MARKETING AUTHORISATION

● **Periodic safety update reports**

The requirements for submission of periodic safety update reports for this medicinal product are set out in the list of Union reference dates (EURD list) provided for under Article 107c(7) of Directive 2001/83/EC and any subsequent updates published on the European medicines web-portal.

D. CONDITIONS OR RESTRICTIONS WITH REGARD TO THE SAFE AND EFFECTIVE USE OF THE MEDICINAL PRODUCT

● **Risk Management Plan (RMP)**

The MAH shall perform the required pharmacovigilance activities and interventions detailed in the agreed RMP presented in Module 1.8.2 of the Marketing Authorisation and any agreed subsequent updates of the RMP.

An updated RMP should be submitted:

- At the request of the European Medicines Agency;
- Whenever the risk management system is modified, especially as the result of new information being received that may lead to a significant change to the benefit/risk profile or as the result of an important (pharmacovigilance or risk minimisation) milestone being reached.

- **Obligation to conduct post-authorisation measures**

The MAH shall complete, within the stated timeframe, the below measures:

Description	Due date
A post-authorisation safety study to further investigate the risks of disease progression and mortality associated with Lonquex in patients with malignancy treated with cytotoxic chemotherapy. Risks should be determined in relation to an established comparator and placebo and objective evaluation of disease progression should occur. A suitably sensitive clinical model should be selected in which to evaluate the above risks. Submission of final study report.	31/12/2017

ANNEX III
LABELLING AND PACKAGE LEAFLET

A. LABELLING

PARTICULARS TO APPEAR ON THE OUTER PACKAGING

OUTER CARTON

1. NAME OF THE MEDICINAL PRODUCT

Lonquex 6 mg solution for injection in pre-filled syringe
Lipegfilgrastim

2. STATEMENT OF ACTIVE SUBSTANCE(S)

Each pre-filled syringe contains 6 mg lipegfilgrastim in 0.6 ml solution. Each ml of solution contains 10 mg lipegfilgrastim.

3. LIST OF EXCIPIENTS

Excipients: Glacial acetic acid, sodium hydroxide, sorbitol (E420), polysorbate 20 and water for injections.
Read the package leaflet before use.

4. PHARMACEUTICAL FORM AND CONTENTS

Solution for injection

1 pre-filled syringe
1 pre-filled syringe with safety device

5. METHOD AND ROUTE(S) OF ADMINISTRATION

For single use only.

Avoid vigorous shaking.

Read the package leaflet before use.

Subcutaneous use

Only for the pre-filled syringe with safety device:
Important: read the package leaflet before handling syringe.

6. SPECIAL WARNING THAT THE MEDICINAL PRODUCT MUST BE STORED OUT OF THE SIGHT AND REACH OF CHILDREN

Keep out of the sight and reach of children.

7. OTHER SPECIAL WARNING(S), IF NECESSARY

8. EXPIRY DATE

EXP

9. SPECIAL STORAGE CONDITIONS

Store in a refrigerator.

Do not freeze.

Keep the pre-filled syringe in the outer carton in order to protect from light.

10. SPECIAL PRECAUTIONS FOR DISPOSAL OF UNUSED MEDICINAL PRODUCTS OR WASTE MATERIALS DERIVED FROM SUCH MEDICINAL PRODUCTS, IF APPROPRIATE**11. NAME AND ADDRESS OF THE MARKETING AUTHORISATION HOLDER**

UAB "Sicor Biotech"
Molėtų pl. 5
LT-08409 Vilnius
Lithuania

12. MARKETING AUTHORISATION NUMBER(S)

EU/1/13/856/001 1 pre-filled syringe with safety device
EU/1/13/856/002 1 pre-filled syringe

13. BATCH NUMBER

Batch

14. GENERAL CLASSIFICATION FOR SUPPLY

Medicinal product subject to medical prescription.

15. INSTRUCTIONS ON USE**16. INFORMATION IN BRAILLE**

Lonquex 6 mg

17. UNIQUE IDENTIFIER – 2D BARCODE

2D barcode carrying the unique identifier included.

18. UNIQUE IDENTIFIER - HUMAN READABLE DATA

PC:
SN:
NN:

**MINIMUM PARTICULARS TO APPEAR ON SMALL IMMEDIATE PACKAGING UNITS
PRE-FILLED SYRINGE**

1. NAME OF THE MEDICINAL PRODUCT AND ROUTE(S) OF ADMINISTRATION

Lonquex 6 mg injection
Lipegfilgrastim

SC

2. METHOD OF ADMINISTRATION

3. EXPIRY DATE

EXP

4. BATCH NUMBER

Batch

5. CONTENTS BY WEIGHT, BY VOLUME OR BY UNIT

0.6 ml

6. OTHER

B. PACKAGE LEAFLET

Package leaflet: Information for the user

Lonquex 6 mg solution for injection in pre-filled syringe

Lipegfilgrastim

▼ This medicine is subject to additional monitoring. This will allow quick identification of new safety information. You can help by reporting any side effects you may get. See the end of section 4 for how to report side effects.

Read all of this leaflet carefully before you start using this medicine because it contains important information for you.

- Keep this leaflet. You may need to read it again.
- If you have any further questions, ask your doctor, pharmacist or nurse.
- This medicine has been prescribed for you only. Do not pass it on to others. It may harm them, even if their signs of illness are the same as yours.
- If you get any side effects, talk to your doctor, pharmacist or nurse. This includes any possible side effects not listed in this leaflet. See section 4.

What is in this leaflet

1. What Lonquex is and what it is used for
2. What you need to know before you use Lonquex
3. How to use Lonquex
4. Possible side effects
5. How to store Lonquex
6. Contents of the pack and other information
7. Information for injecting yourself

1. What Lonquex is and what it is used for

What Lonquex is

Lonquex contains the active substance lipegfilgrastim. Lipegfilgrastim is a long-acting modified protein produced by biotechnology in bacteria called *Escherichia coli*. It belongs to a group of proteins called cytokines and is similar to a natural protein (granulocyte-colony stimulating factor [G-CSF]) produced by your own body.

What Lonquex is used for

Your doctor has prescribed Lonquex for you in order to reduce the duration of a condition called neutropenia (low white blood cell count) and the occurrence of febrile neutropenia (low white blood cell count with a fever). These can be caused by the use of cytotoxic chemotherapy (medicines that destroy rapidly-growing cells).

How Lonquex works

Lipegfilgrastim stimulates the bone marrow (the tissue where new blood cells are made) to produce more white blood cells. White blood cells are important as they help your body fight infection. These cells are very sensitive to the effects of chemotherapy which can cause the number of these cells in your body to decrease. If white blood cells fall to a low level, there may not be enough left in the body to fight bacteria and you may have an increased risk of infection.

2. What you need to know before you use Lonquex

Do not use Lonquex:

- if you are allergic to lipegfilgrastim or any of the other ingredients of this medicine (listed in section 6).

Warnings and precautions

Talk to your doctor, pharmacist or nurse before using Lonquex

- if you get left upper abdominal pain or pain at the tip of your shoulder. It could be a consequence of a spleen disorder (see section “4. Possible side effects”).
- if you have a cough, fever and difficulty breathing. It could be a consequence of a pulmonary disorder (see section “4. Possible side effects”).
- if you have sickle cell anaemia, which is an inherited disease characterised by sickle-shaped red blood cells.
- if you have previously experienced allergic reactions to other medicines like this one (e.g. filgrastim, lenograstim or pegfilgrastim of the group of G-CSFs). There could be a risk of reacting to Lonquex too.

Your doctor will carry out regular blood tests in order to monitor various blood components and their levels.

Children and adolescents

Do not give this medicine to children and adolescents under 18 years of age because there is only limited experience in children to show that this medicine is safe and works in this age group.

Other medicines and Lonquex

Tell your doctor or pharmacist if you are using, have recently used or might use any other medicines.

You will normally inject your dose of Lonquex approximately 24 hours after your last dose of chemotherapy at the end of each chemotherapy cycle.

Pregnancy and breast-feeding

Lonquex has not been tested in pregnant women. It is important to tell your doctor if you are pregnant, think you may be pregnant or are planning to have a baby, as the doctor may decide that you should not use this medicine.

It is unknown whether the active substance in this medicine passes into the breast milk. You should therefore interrupt breast-feeding during treatment..

Driving and using machines

Lonquex has no or negligible influence on your ability to drive and use machines.

Lonquex contains sorbitol and sodium

This medicine contains sorbitol. If you have been told by your doctor that you have an intolerance to some sugars, contact your doctor before using this medicine.

This medicine contains less than 1 mmol sodium (23 mg) per pre-filled syringe, i.e. essentially ‘sodium-free’.

3. How to use Lonquex

Always use this medicine exactly as your doctor or pharmacist has told you. Check with your doctor or pharmacist if you are not sure.

What the recommended dose is

The recommended dose is one pre-filled syringe (6 mg lipegfilgrastim) *once per chemotherapy cycle*.

When to use Lonquex

This medicine should be given approximately 24 hours after your last dose of chemotherapy at the end of each chemotherapy cycle.

How are the injections given?

This medicine is given as an injection using a pre-filled syringe. The injection is given into the tissue just under the skin (subcutaneous injection).

Your doctor may suggest that you learn how to inject yourself with this medicine. Your doctor or nurse will give you instructions on how to do this. Do not attempt to give Lonquex to yourself without this training. Information required for using the pre-filled syringe can be found at the end of this package leaflet (see section “7. Information for injecting yourself”). Proper treatment of your disease, however, requires close and constant co-operation with your doctor.

If you use more Lonquex than you should

If you use more Lonquex than you should, talk to your doctor.

If you forget to use Lonquex

If you have missed an injection, contact your doctor to discuss when you should inject the next dose.

If you have any further questions on the use of this medicine, ask your doctor, pharmacist or nurse.

4. Possible side effects

Like all medicines, this medicine can cause side effects, although not everybody gets them.

Most serious side effects

- Allergic reactions such as skin rash, raised itchy areas of skin and serious allergic reactions with weakness, drop in blood pressure, difficulty breathing and swelling of the face have been reported uncommonly (may affect up to 1 in 100 people). If you think you are having this type of reaction, you must stop your Lonquex injection and get medical help immediately.
- Increased spleen size has been reported uncommonly (may affect up to 1 in 100 people) and cases of splenic ruptures have been reported with other medicines similar to Lonquex. Some cases of splenic rupture were fatal. It is important to contact your doctor immediately if you experience *pain in the upper left side of the abdomen or left shoulder pain* since this may relate to a problem with your spleen.
- Cough, fever and difficult or painful breathing can be signs of uncommon (may affect up to 1 in 100 people) serious pulmonary side effects, such as pneumonia and acute respiratory distress syndrome, which may be fatal. If you have a fever or any of these symptoms, it is important to contact your doctor immediately.
- It is important to contact your doctor immediately if you have any of the following symptoms: swelling or puffiness, which may be associated with passing water less frequently, difficulty breathing, abdominal swelling and feeling of fullness, and a general feeling of tiredness. These symptoms generally develop in a rapid fashion. These could be symptoms of a condition reported with other medicines similar to Lonquex called “capillary leak syndrome”, which causes blood to leak from the small blood vessels into your body and needs urgent medical attention.

Other side effects

Very common (may affect more than 1 in 10 people)

- Musculoskeletal pains such as bone pain and pain in the joints, muscles, limbs, chest, neck or back. Your doctor will tell you what you can take to ease the bone pain.

Common (may affect up to 1 in 10 people)

- Reduction in blood platelets, which increases risk of bleeding or bruising.
- Headache.
- Skin reactions, such as redness or rash.
- Low blood levels of potassium, which can cause muscle weakness, twitching or abnormal heart rhythm.

- Chest pain.

Uncommon (may affect up to 1 in 100 people)

- Rise in white blood cells.
- Local reactions at the injection site, such as pain or hardening.
- Some changes may occur in your blood, but these will be detected by routine blood tests.

Side effects that have been seen with similar medicines, but not yet with Lonquex

- Sickle cell crises in patients with sickle cell anaemia.
- Plum-coloured raised painful sores on the limbs and sometimes the face and neck with fever (Sweet's syndrome).
- Inflammation of the blood vessels in the skin.

Reporting of side effects

If you get any side effects, talk to your doctor, pharmacist or nurse. This includes any possible side effects not listed in this leaflet. You can also report side effects directly via the national reporting system listed in Appendix V. By reporting side effects you can help provide more information on the safety of this medicine.

5. How to store Lonquex

Keep this medicine out of the sight and reach of children.

Do not use this medicine after the expiry date which is stated on the outer carton and on the label of the pre-filled syringe after EXP. The expiry date refers to the last day of that month.

Store in a refrigerator (2 °C – 8 °C).

Do not freeze.

Keep the pre-filled syringe in the outer carton, in order to protect from light.

Lonquex may be removed from the refrigerator and stored below 25 °C for a maximum single period of up to 3 days. Once removed from the refrigerator, the medicine must be used within this period or disposed of.

Do not use this medicine if you notice that it is cloudy or there are particles in it.

Dispose of this medicine as instructed by your doctor, pharmacist or nurse.

6. Contents of the pack and other information

What Lonquex contains

- The active substance is lipegfilgrastim. Each pre-filled syringe contains 6 mg lipegfilgrastim. Each ml solution contains 10 mg lipegfilgrastim.
- The other ingredients (excipients) are glacial acetic acid, sodium hydroxide, sorbitol (E420), polysorbate 20 and water for injections.

What Lonquex looks like and contents of the pack

Lonquex is a solution for injection (injection) in pre-filled syringe with a fixed injection needle in a blister. Lonquex is a clear and colourless solution. Each pre-filled syringe contains 0.6 ml solution.

Each pack contains 1 pre-filled syringe with or without safety device.

Not all pack sizes may be marketed.

Marketing Authorisation Holder

UAB "Sicor Biotech"
Molėtų pl. 5
LT-08409 Vilnius
Lithuania

Manufacturer

Teva Biotech GmbH
Dornierstraße 10
89079 Ulm
Germany

Teva Pharmaceuticals Europe B.V.
Swensweg 5
2031 GA Haarlem
The Netherlands

For any information about this medicine, please contact the local representative of the Marketing Authorisation Holder:

België/Belgique/Belgien

Teva Pharma Belgium N.V./S.A./AG
Tél/Tel: +32 3 820 73 73

Lietuva

UAB "Sicor Biotech"
Tel: +370 5 266 0203

България

Тева Фармасютикълс България ЕООД
Тел: +359 2 489 95 82

Luxembourg/Luxemburg

Teva Pharma Belgium N.V./S.A./AG,
Belgique/Belgien
Tél/Tel: +32 3 820 73 73

Česká republika

Teva Pharmaceuticals CR, s.r.o.
Tel: +420 251 007 111

Magyarország

Teva Gyógyszergyár Zrt.
Tel.: +36 1 288 64 00

Danmark

Teva Denmark A/S
Tlf: +45 44 98 55 11

Malta

Teva Pharmaceuticals Ireland, L-Irlanda
Tel: +353 51 321740

Deutschland

TEVA GmbH
Tel: +49 731 402 08

Nederland

Teva Nederland B.V.
Tel: +31 800 0228 400

Eesti

UAB "Sicor Biotech" Eesti filiaal
Tel: +372 661 0801

Norge

Teva Norway AS
Tlf: +47 66 77 55 90

Ελλάδα

Teva Ελλάς Α.Ε.
Τηλ: +30 210 72 79 099

Österreich

ratiopharm Arzneimittel Vertriebs-GmbH
Tel: +43 1 97 007

España

Teva Pharma, S.L.U.
Tél: +34 91 387 32 80

Polska

Teva Pharmaceuticals Polska Sp. z o.o.
Tel.: +48 22 345 93 00

France

Teva Santé
Tél: +33 1 55 91 78 00

Portugal

Teva Pharma - Produtos Farmacêuticos, Lda
Tel: +351 21 476 75 50

Hrvatska

Pliva Hrvatska d.o.o.
Tel: +385 1 37 20 000

Ireland

Teva Pharmaceuticals Ireland
Tel: +353 51 321740

Ísland

Vistor hf.
Sími: +354 535 7000

Italia

Teva Italia S.r.l.
Tel: +39 02 89 17 98 1

Κύπρος

Teva Ελλάς A.E., Ελλάδα
Τηλ: +30 210 72 79 099

Latvija

UAB "Sicor Biotech" filiāle Latvijā
Tel: +371 673 23 666

România

Teva Pharmaceuticals S.R.L.
Tel: +40 21 230 65 24

Slovenija

Pliva Ljubljana d.o.o.
Tel: +386 1 58 90 390

Slovenská republika

TEVA Pharmaceuticals Slovakia s.r.o.
Tel: +421 2 57 26 79 11

Suomi/Finland

Teva Finland
Puh/Tel: +358 20 180 5900

Sverige

Teva Sweden AB
Tel: +46 42 12 11 00

United Kingdom

Teva UK Limited
Tel: +44 1977 628500

This leaflet was last revised in {month YYYY}.

Detailed information on this medicine is available on the European Medicines Agency web site:
<http://www.ema.europa.eu>.

7. Information for injecting yourself

This section contains information on how to give yourself an injection of Lonquex under the skin. It is important that you do not try to give yourself the injection unless you have received special training from your doctor or nurse. If you are not sure about giving yourself the injection or you have any questions, please ask your doctor or nurse for help.

How Lonquex is used

You will need to give yourself the injection into the tissue just under the skin. This is known as a subcutaneous injection.

Equipment that you need

To give yourself an injection into the tissue under the skin you will need:

- a pre-filled syringe of Lonquex,
- an alcohol wipe,
- a piece of gauze bandage or a sterile gauze swab,
- a puncture-proof container (plastic container provided by the hospital or pharmacy) so you can dispose of used syringes safely.

What you should do before your injection

1. Take the medicine out of the refrigerator.
2. Open the blister and take the pre-filled syringe out of the blister. Do not pick up the pre-filled syringe by the plunger or needle cover.
3. Check the expiry date on the pre-filled syringe label (EXP). Do not use it if the date has passed the last day of the month shown.
4. Check the appearance of Lonquex. It must be a clear and colourless liquid. If there are particles in it or if it is cloudy, you must not use it.
5. Do not shake Lonquex vigorously as this may affect its activity.
6. For a more comfortable injection, let the pre-filled syringe stand for 30 minutes to reach room temperature (not above 25 °C) or hold the pre-filled syringe gently in your hand for a few minutes. Do **not** warm Lonquex in any other way (for example, do not warm it in a microwave or in hot water).
7. Do **not** remove the needle cover from the syringe until you are ready to inject.
8. Find a comfortable, well-lit place. Put everything you need within easy reach (the Lonquex pre-filled syringe, an alcohol wipe, a piece of gauze bandage or a sterile gauze swab and the puncture-proof container).
9. **Wash your hands thoroughly.**

How to prepare for your injection

Before you give yourself a Lonquex injection, you must do the following:

1. Hold the syringe and gently remove the cover from the needle without twisting. Pull straight as shown in pictures 1 and 2. Do not touch the needle or push the plunger.
2. You may notice small air bubbles in the pre-filled syringe. If there are air bubbles present, gently tap the syringe with your fingers until the air bubbles rise to the top of the syringe. With the syringe pointing upwards, expel all air from the syringe by pushing the plunger slowly upwards.
3. You can now use the pre-filled syringe.

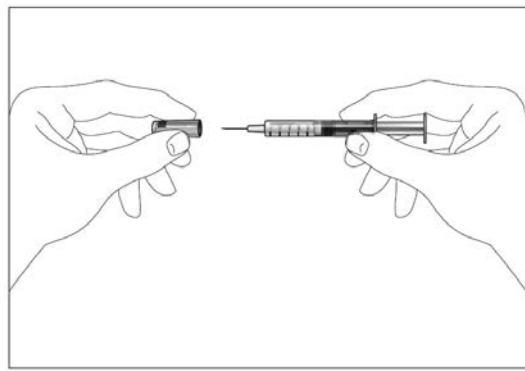
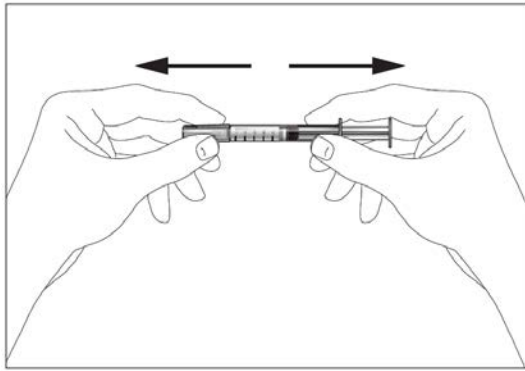

Where your injection should be given

The most suitable places to inject yourself are:

- the top of your thighs,
- the abdomen (see grey areas in picture 3) avoiding the skin directly surrounding the navel.

If someone else is injecting you, they can also use the back and side of your upper arms (see grey areas in pictures 4 and 5).

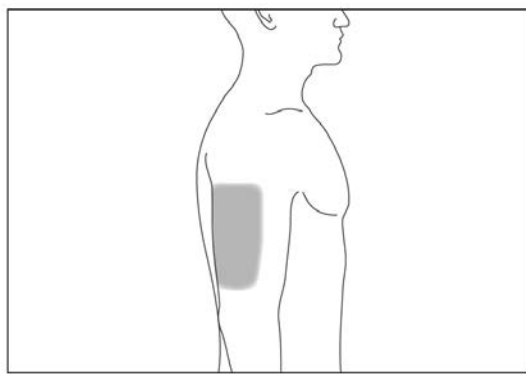
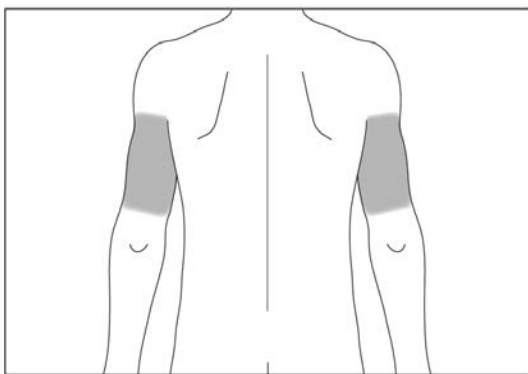
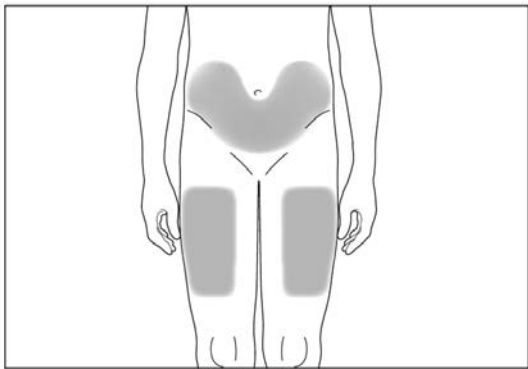

How you should inject yourself

1. Disinfect the injection site on the skin by using an alcohol wipe and pinch the skin between your thumb and forefinger, without squeezing it (see picture 6).
2. Put the needle fully into the skin as shown by your doctor or nurse. The angle between the syringe and skin should not be too narrow (at least 45°, see picture 7).
3. Pull slightly on the plunger to check that a blood vessel has not been punctured. If you see blood in the syringe, remove the needle and re-insert it in another place.
4. Inject the liquid into the tissue slowly and evenly, always keeping your skin pinched.
5. After injecting the liquid, remove the needle and let go of your skin.
6. Press the injection site with a piece of gauze bandage or a sterile gauze swab for several seconds.
7. Only use each syringe for one injection. Do not use any Lonquex that is left in the syringe.

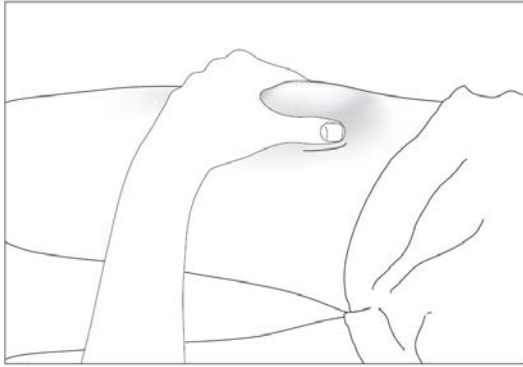

6

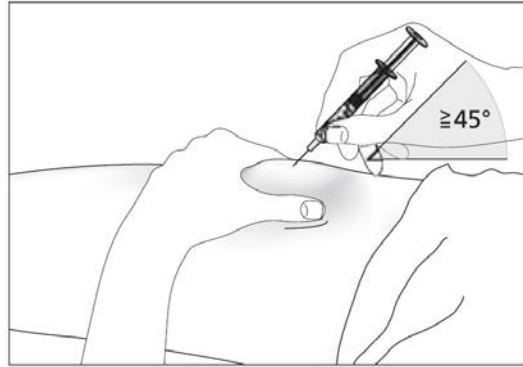

7

Remember

If you have any problems, please ask your doctor or nurse for help and advice.

Disposing of used syringes

- Do not put the cover back on used needles.
- Put used syringes into the puncture-proof container and keep this container out of the sight and reach of children.
- Dispose of the full puncture-proof container as instructed by your doctor, pharmacist or nurse.
- Never put the syringes that you have used into your normal household rubbish bin.

7. Information for injecting yourself

This section contains information on how to give yourself an injection of Lonquex under the skin. It is important that you do not try to give yourself the injection unless you have received special training from your doctor or nurse. If you are not sure about giving yourself the injection or you have any questions, please ask your doctor or nurse for help.

How Lonquex is used

You will need to give yourself the injection into the tissue just under the skin. This is known as a subcutaneous injection.

Equipment that you need

To give yourself an injection into the tissue under the skin you will need:

- a pre-filled syringe of Lonquex,
- an alcohol wipe,
- a piece of gauze bandage or a sterile gauze swab.

What you should do before your injection

1. Take the medicine out of the refrigerator.
2. Open the blister and take the pre-filled syringe out of the blister (see picture 1). Do not pick up the pre-filled syringe by the plunger or needle cover. This could damage the safety device.
3. Check the expiry date on the pre-filled syringe label (EXP). Do not use it if the date has passed the last day of the month shown.
4. Check the appearance of Lonquex. It must be a clear and colourless liquid. If there are particles in it or if it is cloudy, you must not use it.
5. Do not shake Lonquex vigorously as this may affect its activity.
6. For a more comfortable injection, let the pre-filled syringe stand for 30 minutes to reach room temperature (not above 25 °C) or hold the pre-filled syringe gently in your hand for a few minutes. Do **not** warm Lonquex in any other way (for example, do not warm it in a microwave or in hot water).
7. Do **not** remove the needle cover from the syringe until you are ready to inject.
8. Find a comfortable, well-lit place. Put everything you need within easy reach (the Lonquex pre-filled syringe, an alcohol wipe and a piece of gauze bandage or a sterile gauze swab).
9. **Wash your hands thoroughly.**

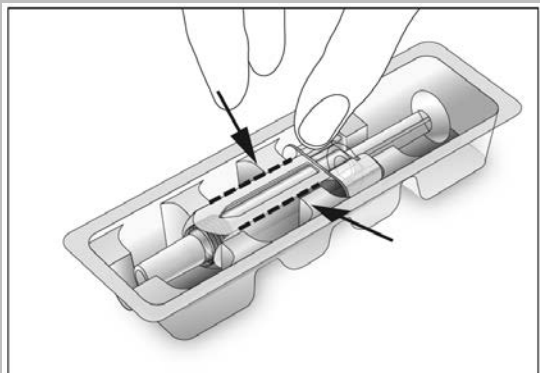

How to prepare for your injection

Before you give yourself a Lonquex injection, you must do the following:

1. Hold the syringe and gently remove the cover from the needle without twisting. Pull straight as shown in pictures 2 and 3. Do not touch the needle or push the plunger.
2. You may notice small air bubbles in the pre-filled syringe. If there are air bubbles present, gently tap the syringe with your fingers until the air bubbles rise to the top of the syringe. With the syringe pointing upwards, expel all air from the syringe by pushing the plunger slowly upwards.
3. You can now use the pre-filled syringe.

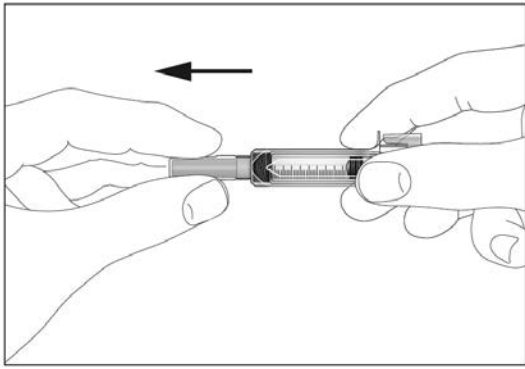

2

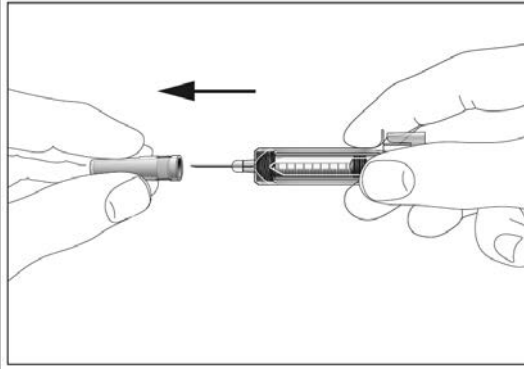

3

Where your injection should be given

The most suitable places to inject yourself are:

- the top of your thighs,
- the abdomen (see grey areas in picture 4) avoiding the skin directly surrounding the navel.

If someone else is injecting you, they can also use the back and side of your upper arms (see grey areas in pictures 5 and 6).

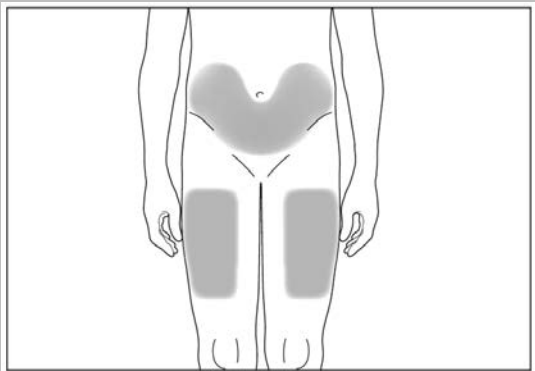

4

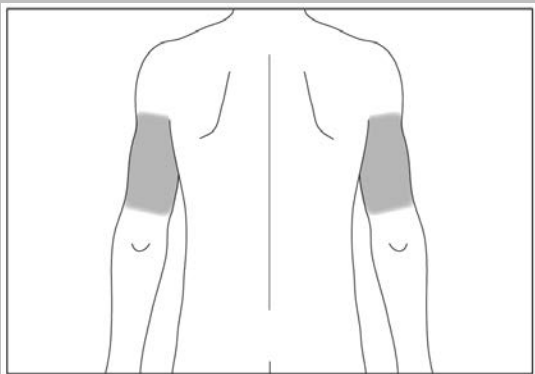

5

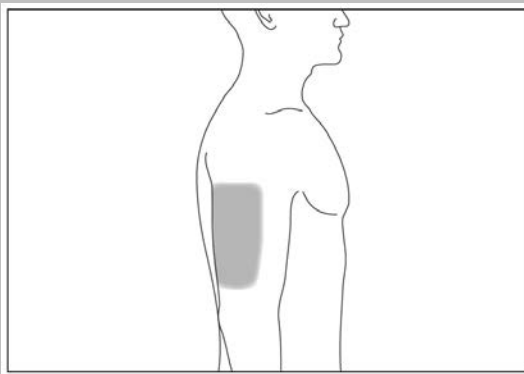

6

How you should inject yourself

1. Disinfect the injection site on the skin by using an alcohol wipe and pinch the skin between your thumb and forefinger, without squeezing it (see picture 7).
2. Put the needle fully into the skin as shown by your doctor or nurse. The angle between the syringe and skin should not be too narrow (at least 45°, see picture 8).
3. Pull slightly on the plunger to check that a blood vessel has not been punctured. If you see blood in the syringe, remove the needle and re-insert it in another place.
4. Inject the liquid into the tissue slowly and evenly, always keeping your skin pinched (see picture 9).
5. Push the plunger as far as it will go to inject all the liquid. While the plunger is still pressed all the way down, remove the needle from the skin (see picture 10). Then release the plunger. The safety device will be activated immediately. The entire needle and syringe will be drawn back automatically and covered so that you cannot prick yourself (see picture 11).

6. Press the injection site with a piece of gauze bandage or a sterile gauze swab for several seconds.
7. Each pre-filled syringe is for single use only.

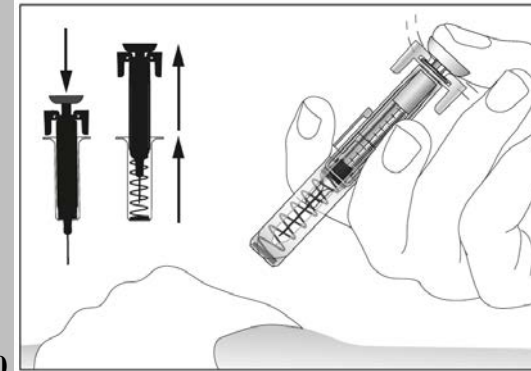
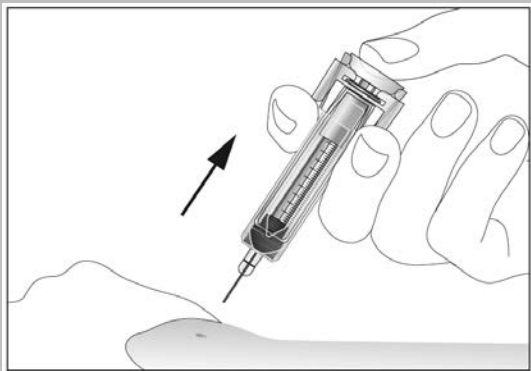
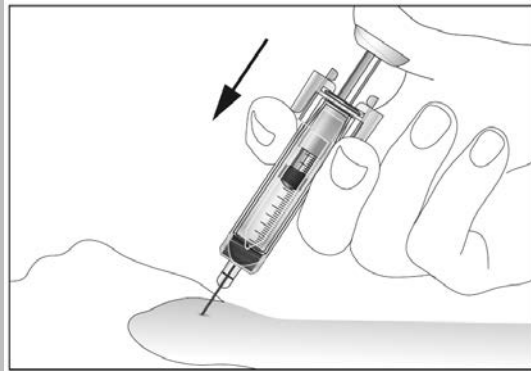
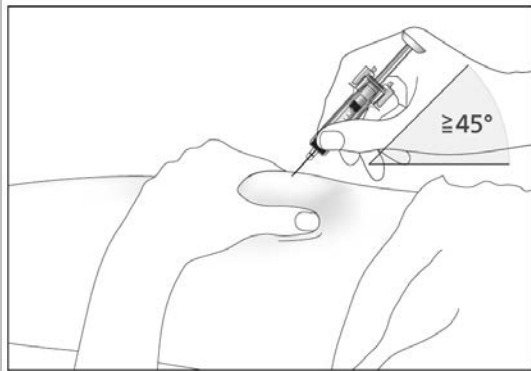
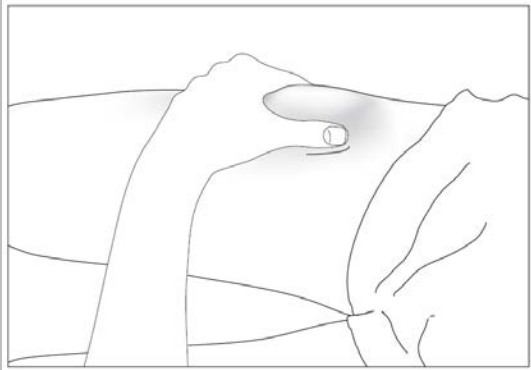

Remember

If you have any problems, please ask your doctor or nurse for help and advice.