

ANNEX I
SUMMARY OF PRODUCT CHARACTERISTICS

▼ This medicinal product is subject to additional monitoring. This will allow quick identification of new safety information. Healthcare professionals are asked to report any suspected adverse reactions. See section 4.8 for how to report adverse reactions.

1. NAME OF THE MEDICINAL PRODUCT

Vabysmo 120 mg/mL solution for injection

Vabysmo 120 mg/mL solution for injection in pre-filled syringe

2. QUALITATIVE AND QUANTITATIVE COMPOSITION

One mL of solution contains 120 mg of faricimab.

Pre-filled syringe

Each pre-filled syringe contains 21 mg faricimab in 0.175 mL solution. This provides a usable amount to deliver a single dose of 0.05 mL solution containing 6 mg of faricimab.

Vial

Each vial contains 28.8 mg faricimab in 0.24 mL solution. This provides a usable amount to deliver a single dose of 0.05 mL solution containing 6 mg of faricimab.

Faricimab is a humanised antibody produced in mammalian Chinese Hamster Ovary (CHO) cell culture by recombinant DNA technology.

Excipients with known effect

Each 0.05 mL solution contains 0.02 mg polysorbate and 0.07 mg sodium.

For the full list of excipients, see section 6.1.

3. PHARMACEUTICAL FORM

Solution for injection (injection)

Clear to opalescent, colourless to brownish-yellow solution, with a pH of 5.5 and an osmolality of 270-370 mOsm/kg.

4. CLINICAL PARTICULARS

4.1 Therapeutic indications

Vabysmo is indicated for the treatment of adult patients with:

- neovascular (wet) age-related macular degeneration (nAMD),
- visual impairment due to diabetic macular oedema (DME),
- visual impairment due to macular oedema secondary to retinal vein occlusion (branch RVO or central RVO).

4.2 Posology and method of administration

This medicinal product must be administered by a qualified physician experienced in intravitreal injections.

Posology

Neovascular (wet) age-related macular degeneration (nAMD)

The recommended dose is 6 mg (0.05 mL solution) administered by intravitreal injection every 4 weeks (monthly) for the first 3 doses.

Thereafter, an assessment of disease activity based on anatomic and/or visual outcomes is recommended 16 and/or 20 weeks after treatment initiation so that treatment can be individualised. In patients without disease activity, administration of faricimab every 16 weeks (4 months) should be considered. In patients with disease activity, treatment every 8 weeks (2 months) or 12 weeks (3 months) should be considered. If anatomic and/or visual outcomes change, the treatment interval should be adjusted accordingly, and interval reduction should be implemented if anatomic and/or visual outcomes deteriorate (see section 5.1). There is limited safety data on treatment intervals of 8 weeks or less between injections (see section 4.4). Monitoring between the dosing visits should be scheduled based on the patient's status and at the physician's discretion, but there is no requirement for monthly monitoring between injections.

Visual impairment due to diabetic macular oedema (DME) and macular oedema secondary to retinal vein occlusion (RVO)

The recommended dose is 6 mg (0.05 mL solution) administered by intravitreal injection every 4 weeks (monthly); 3 or more consecutive, monthly injections may be needed.

Thereafter, treatment is individualised using a treat -and-extend approach. Based on the physician's judgement of the patient's anatomic and/or visual outcomes, the dosing interval may be extended in increments of up to 4 weeks. If anatomic and/or visual outcomes change, the treatment interval should be adjusted accordingly, and interval reduction should be implemented if anatomic and/or visual outcomes deteriorate (see section 5.1). Treatment intervals shorter than 4 weeks and longer than 4 months between injections have not been studied. Monitoring between the dosing visits should be scheduled based on the patient's status and at the physician's discretion but there is no requirement for monthly monitoring between injections.

Duration of treatment

This medicinal product is intended for long-term treatment. If visual and/or anatomic outcomes indicate that the patient is not benefitting from continued treatment, treatment should be discontinued.

Delayed or missed dose

If a dose is delayed or missed, the patient should return to be assessed by physician at the next available visit and continue dosing depending on physician's discretion.

Special populations

Elderly

No dose adjustment is required in patients aged 65 years or above (see section 5.2). Safety data in nAMD and RVO patients \geq 85 years is limited (see section 4.4).

Renal impairment

No dose adjustment is required in patients with renal impairment (see section 5.2).

Hepatic impairment

No dose adjustment is required in patients with hepatic impairment (see section 5.2).

Paediatric population

There is no relevant use of this medicinal product in the paediatric population for the indications of nAMD, DME, and RVO.

Method of administration

For intravitreal use only. Each pre-filled syringe or vial should only be used for the treatment of a single eye.

Vabysmo should be inspected visually for particulate matter and discoloration prior to administration, and if present, the pre-filled syringe or vial should not be used.

The intravitreal injection procedure should be carried out under aseptic conditions, which includes the use of surgical hand disinfection, a sterile drape and a sterile eyelid speculum (or equivalent). The patient's medical history for hypersensitivity reactions should be carefully evaluated prior to performing the intravitreal procedure (see section 4.8). Adequate anaesthesia and a broad-spectrum topical microbicide to disinfect the periocular skin, eyelid, and ocular surface should be administered prior to the injection.

Pre-filled syringe

The pre-filled syringe contains an excess of volume. The excess volume must be expelled before injecting the recommended dose. Injecting the entire volume of the pre-filled syringe could result in overdose.

To expel the air bubbles along with excess medicinal product, slowly push the plunger rod until the lower edge of the rubber stopper's dome is aligned with the 0.05 mL dose mark (see sections 4.9 and 6.6).

The injection filter needle (included in the package) should be inserted 3.5 to 4.0 mm posterior to the limbus into the vitreous cavity, avoiding the horizontal meridian and aiming towards the centre of the globe. The injection volume of 0.05 mL is then delivered slowly; a different scleral site should be used for subsequent injections.

Vial

The injection needle (30-gauge x ½ inch, not included in the package) should be inserted 3.5 to 4.0 mm posterior to the limbus into the vitreous cavity, avoiding the horizontal meridian and aiming towards the centre of the globe. The injection volume of 0.05 mL is then delivered slowly; a different scleral site should be used for subsequent injections.

Post-injection monitoring

After injection, any unused medicinal product or waste material should be disposed of in accordance with local requirements.

Immediately following the intravitreal injection, patients should be monitored for elevation in intraocular pressure. Appropriate monitoring may consist of a check for perfusion of the optic nerve head or tonometry. If required, sterile equipment for paracentesis should be available.

Following intravitreal injection patients should be instructed to report any symptoms suggestive of endophthalmitis (e.g. vision loss, eye pain, redness of the eye, photophobia, blurring of vision) without delay.

For instructions on handling of the medicinal product before administration, see section 6.6.

4.3 Contraindications

Hypersensitivity to the active substance or to any of the excipients listed in section 6.1.

Active or suspected ocular or periocular infections.

Active intraocular inflammation.

4.4 Special warnings and precautions for use

Traceability

In order to improve the traceability of biological medicinal products, the name and the batch number of the administered medicinal product should be clearly recorded.

Intravitreal injection-related reactions

Intravitreal injections, including those with faricimab, have been associated with endophthalmitis, intraocular inflammation, rhegmatogenous retinal detachment, retinal tear, and iatrogenic traumatic cataract (see section 4.8). Proper aseptic injection techniques must always be used when administering Vabysmo. Patients should be instructed to report any symptoms, such as pain, loss of vision, photophobia, blurred vision, floaters, or redness, suggestive of endophthalmitis or any of the above-mentioned adverse reactions without delay, to permit prompt and appropriate management. Patients with increased frequency of injections may be at increased risk of procedural complications.

Intraocular pressure increases

Transient increases in intraocular pressure (IOP) have been seen within 60 minutes of intravitreal injection, including those with faricimab (see section 4.8). Special precaution is needed in patients with poorly controlled glaucoma (do not inject Vabysmo while the IOP is ≥ 30 mmHg). In all cases, both the IOP and perfusion of the optic nerve head must be monitored and managed appropriately.

Systemic effects

Systemic adverse events including arterial thromboembolic events have been reported following intravitreal injection of vascular endothelial growth factor (VEGF) inhibitors and there is a theoretical risk that these may be related to VEGF inhibition. A low incidence rate of arterial thromboembolic events was observed in the faricimab clinical trials in patients with nAMD, DME, and RVO. There are limited data on the safety of faricimab treatment in DME patients with high blood pressure ($\geq 140/90$ mmHg) and vascular disease, and in nAMD and RVO patients ≥ 85 years of age.

Immunogenicity

As this is a therapeutic protein, there is a potential for immunogenicity with faricimab (see section 4.8). Patients should be instructed to inform their physician of any signs or symptoms of intraocular inflammation such as vision loss, eye pain, increased sensitivity to light, floaters or worsening eye redness, which might be a clinical sign attributable to hypersensitivity against faricimab (see section 4.8).

Bilateral treatment

The safety and efficacy of faricimab administered in both eyes concurrently have not been studied. Bilateral treatment could cause bilateral ocular adverse reactions and/or potentially lead to an increase in systemic exposure, which could increase the risk of systemic adverse reactions. Until data for bilateral use become available, this is a theoretical risk for faricimab.

Concomitant use of other anti-VEGF

There are no data available on the concomitant use of faricimab with anti-VEGF medicinal products in the same eye. Faricimab should not be administered concurrently with other anti-VEGF medicinal products (systemic or ocular).

Use of other injection needles with the pre-filled syringe

Only use the pre-filled syringe with the co-packaged injection filter needle. There are no clinical data available on the use of other injection needles with the pre-filled syringe.

Withholding treatment

Treatment should be withheld in patients with:

- Rhegmatogenous retinal detachment, stage 3 or 4 macular holes, retinal break; treatment should not be resumed until an adequate repair has been performed.
- Treatment related decrease in Best Corrected Visual Acuity (BCVA) of ≥ 30 letters compared with the last assessment of visual acuity; treatment should not be resumed earlier than the next scheduled treatment.
- An intraocular pressure of ≥ 30 mmHg.
- A subretinal haemorrhage involving the centre of the fovea, or, if the size of the haemorrhage is $\geq 50\%$, of the total lesion area.
- Performed or planned intraocular surgery within the previous or next 28 days; treatment should not be resumed earlier than the next scheduled treatment.

Retinal pigment epithelial tear

Retinal pigment epithelial (RPE) tear is a complication of pigment epithelial detachment (PED) in patients with nAMD. Risk factors associated with the development of a retinal pigment epithelial tear after anti-VEGF therapy for nAMD, include a large and/or high pigment epithelial detachment. When initiating faricimab therapy, caution should be used in patients with these risk factors for retinal pigment epithelial tears. RPE tears are common in nAMD patients with PED, treated with intravitreal anti-VEGF agents including faricimab. There was a higher rate of RPE tear in the faricimab group (2.9%) compared to aflibercept group (1.5%). The majority of events occurred during the loading phase, and were mild to moderate, without impact on vision.

Populations with limited data

There is only limited experience in the treatment of nAMD and RVO patients ≥ 85 years, and DME patients with type I diabetes, patients with HbA1c over 10%, patients with high-risk proliferative diabetic retinopathy (DR), high blood pressure ($\geq 140/90$ mmHg) and vascular disease, sustained dosing intervals shorter than every 8 weeks (Q8W), or nAMD, DME, and RVO patients with active

systemic infections. There is limited safety information on sustained dosing intervals of 8 weeks or less and these may be associated with a higher risk of ocular and systemic adverse reactions, including serious adverse reactions. There is also no experience of treatment with faricimab in diabetic or RVO patients with uncontrolled hypertension and patients with RVO who have failed previous therapy. This lack of information should be considered by the physician when treating such patients.

Sodium content

This medicinal product contains less than 1 mmol sodium (23 mg) per dose, that is to say essentially “sodium-free”.

Polysorbate content

This medicinal product contains 0.02 mg of polysorbate per 0.05 mL dose. Patients with hypersensitivity to polysorbate should not take this medicine.

4.5 Interaction with other medicinal products and other forms of interaction

No interaction studies have been performed. Based on the biotransformation and elimination of faricimab (see section 5.2), no interactions are expected. However, faricimab should not be administered concurrently with other systemic or ocular anti-VEGF medicinal products (see section 4.4).

4.6 Fertility, pregnancy and lactation

Women of childbearing potential

Women of childbearing potential should use effective contraception during treatment and for at least 3 months following the last intravitreal injection of faricimab.

Pregnancy

There are no or limited amount of data from the use of faricimab in pregnant women. The systemic exposure to faricimab is low after ocular administration, but due to its mechanism of action (i.e. VEGF inhibition), faricimab must be regarded as potentially teratogenic and embryo-/foetotoxic (see section 5.3).

Faricimab should not be used during pregnancy unless the potential benefit outweighs the potential risk to the foetus.

Breast-feeding

It is unknown whether faricimab is excreted in human milk. A risk to the breast-fed newborn/infant cannot be excluded. Vabysmo should not be used during breast-feeding. A decision must be made whether to discontinue breast-feeding or to discontinue/abstain from faricimab therapy taking into account the benefit of breast-feeding for the child and the benefit of therapy for the woman.

Fertility

No effects on reproductive organs or fertility were observed in a 6-month cynomolgus monkey study with faricimab (see section 5.3).

4.7 Effects on ability to drive and use machines

Vabysmo has a minor influence on the ability to drive and use machines. Temporary visual disturbances may occur following the intravitreal injection and the associated eye examination. Patients should not drive or use machines until visual function has recovered sufficiently.

4.8 Undesirable effects

Summary of the safety profile

The most frequently reported adverse reactions were cataract (10%), conjunctival haemorrhage (7%), vitreous detachment (4%), IOP increased (4%), vitreous floaters (4%), eye pain (3%), and retinal pigment epithelial tear (nAMD only) (3%).

The most serious adverse reactions were uveitis (0.5%), endophthalmitis (0.4%), vitritis (0.4%), retinal tear (0.2%), rhegmatogenous retinal detachment (0.1%), and traumatic cataract (< 0.1%) (see section 4.4).

Tabulated list of adverse reactions

The adverse reactions reported in clinical studies or during post-marketing surveillance are listed according to the MedDRA system organ class and ranked by frequency using the following convention: Very common ($\geq 1/10$), common ($\geq 1/100$ to $< 1/10$), uncommon ($\geq 1/1\ 000$ to $< 1/100$), rare ($\geq 1/10\ 000$ to $< 1/1\ 000$) or not known (frequency cannot be estimated from the available data). Within each frequency grouping, adverse reactions are presented in order of decreasing seriousness.

Table 1: Frequencies of adverse reactions

MedDRA System organ class	Frequency category
Eye disorders	
Cataract	Common
Conjunctival haemorrhage	Common
Vitreous detachment	Common
Increased intraocular pressure	Common
Vitreous floaters	Common
Retinal pigment epithelial tear (nAMD only)	Common
Eye pain	Common
Corneal abrasion	Uncommon
Eye irritation	Uncommon
Increased lacrimation	Uncommon
Blurred vision	Uncommon
Eye pruritus	Uncommon
Ocular discomfort	Uncommon
Ocular hyperaemia	Uncommon
Iritis	Uncommon
Reduced visual acuity	Uncommon
Uveitis	Uncommon
Endophthalmitis	Uncommon
Sensation of foreign body	Uncommon
Vitreous haemorrhage	Uncommon
Vitritis	Uncommon
Iridocyclitis	Uncommon
Conjunctival hyperaemia	Uncommon
Procedural pain	Uncommon
Retinal tear	Uncommon
Rhegmatogenous retinal detachment	Uncommon
Transiently reduced visual acuity	Rare
Traumatic cataract	Rare
Retinal vasculitis*	Not known
Retinal occlusive vasculitis*	Not known

Terms marked with asterisk (*) are adverse reactions which have been identified based on post-marketing spontaneous reports. Because these reactions are reported voluntarily from a population of uncertain size, it is not always possible to reliably estimate their frequency.

Description of selected adverse reactions

Retinal Vasculitis and Retinal Occlusive Vasculitis

Rare cases of retinal vasculitis and/or retinal occlusive vasculitis have been spontaneously reported in the post-marketing setting (see section 4.4). Retinal vasculitis and retinal occlusive vasculitis have also been reported in patients treated with IVT therapies.

Product-class-related adverse reactions

There is a theoretical risk of arterial thromboembolic events, including stroke and myocardial infarction, following intravitreal use of VEGF inhibitors. A low incidence rate of arterial thromboembolic events was observed in the faricimab clinical trials in patients with nAMD, DME, and RVO (see section 4.4). Across indications, no notable difference between the groups treated with faricimab and the comparator were observed.

Immunogenicity

There is a potential for an immune response in patients treated with faricimab (see section 4.4). After dosing with faricimab for up to 112 (nAMD), 100 (DME), and 72 (RVO) weeks, treatment-emergent anti-faricimab antibodies were detected in approximately 13.8%, 9.6%, and 14.4% of patients with nAMD, DME, and RVO randomised to faricimab, respectively. The clinical significance of anti-faricimab antibodies on safety is unclear at this time. The incidence of intraocular inflammation in anti-faricimab antibody positive patients was 12/98 (12.2%; nAMD), 15/128 (11.7%; DME), and 9/95 (9.5%; RVO), and in anti-faricimab antibody negative patients was 8/562 (1.4%; nAMD), 5/1124 (0.4%; DME), and 10/543 (1.8%; RVO). The incidence of serious ocular adverse reactions in anti-faricimab antibody positive patients was 6/98 (6.1%; nAMD), 14/128 (10.9%; DME), and 7/95 (7.4%; RVO), and in anti-faricimab antibody negative patients was 23/562 (4.1%; nAMD), 45/1124 (4.0%; DME), and 34/543 (6.3%; RVO). Anti-faricimab antibodies were not associated with an impact on clinical efficacy or systemic pharmacokinetics.

Reporting of suspected adverse reactions

Reporting suspected adverse reactions after authorisation of the medicinal product is important. It allows continued monitoring of the benefit/risk balance of the medicinal product. Healthcare professionals are asked to report any suspected adverse reactions via the national reporting system listed in [Appendix V](#).

4.9 Overdose

Overdosing with greater than recommended injection volume may increase intraocular pressure. In the event of overdose, IOP should be monitored and, if deemed necessary by the treating physician, appropriate treatment should be initiated.

5. PHARMACOLOGICAL PROPERTIES

5.1 Pharmacodynamic properties

Pharmacotherapeutic group: Ophthalmologicals, antineovascularisation agents, ATC code: S01LA09

Mechanism of action

Faricimab is a humanised bispecific immunoglobulin G1 (IgG1) antibody that acts through inhibition of two distinct pathways by neutralisation of both angiopoietin-2 (Ang-2) and vascular endothelial growth factor A (VEGF-A).

Ang-2 causes vascular instability by promoting endothelial destabilisation, pericyte loss, and pathological angiogenesis, thus potentiating vascular leakage and inflammation. It also sensitises blood vessels to the activity of VEGF-A resulting in further vascular destabilisation. Ang-2 and VEGF-A synergistically increase vascular permeability and stimulate neovascularisation.

By dual inhibition of Ang-2 and VEGF-A, faricimab reduces vascular permeability and inflammation, inhibits pathological angiogenesis and restores vascular stability.

Pharmacodynamic effects

A suppression from baseline of median ocular free Ang-2 and free VEGF-A concentrations was observed from day 7 onwards in the six Phase III studies described hereafter.

nAMD

In TENAYA and LUCERNE, objective, pre-specified visual and anatomic criteria, as well as treating physician clinical assessment, were used to guide treatment decisions at the disease activity assessment time points (week 20 and week 24).

The mean central subfield thickness (CST) reduction from baseline at the primary endpoint visits (averaged at weeks 40-48) was comparable to those observed with aflibercept, with -137 μm and -137 μm in patients treated with faricimab dosed up to every 16 weeks (Q16W) as compared to -129 μm and -131 μm with aflibercept, in TENAYA and LUCERNE, respectively. These mean CST reductions were maintained through year 2.

At week 48, in both studies there was a comparable effect of faricimab and aflibercept on the reduction of intraretinal fluid (IRF), subretinal fluid (SRF), and PED. These effects in IRF, SRF, and PED were maintained at year 2. There were also comparable changes in total CNV lesion area and reductions in CNV leakage area from baseline for patients in the faricimab and aflibercept treatment arms.

DME

In YOSEMITE and RHINE, anatomic parameters related to macular oedema were part of the disease activity assessments guiding treatment decisions.

The mean CST reduction from baseline at the primary endpoint visits (averaged at weeks 48-56) was numerically greater than those observed with aflibercept, with -207 μm and -197 μm in patients treated with faricimab Q8W and faricimab up to Q16W adjustable dosing as compared to -170 μm in aflibercept Q8W patients in YOSEMITE; results were 196 μm , 188 μm , and 170 μm , respectively in RHINE. Consistent reductions in CST were observed through year 2. Greater proportions of patients in both faricimab arms achieved absence of IRF and absence of DME (defined as reaching CST below 325 μm) over time through year 2 as compared to aflibercept in both studies.

RVO

In Phase III studies in patients with branch retinal vein occlusion (BRVO; BALATON) and central/hemiretinal vein occlusion (C/HRVO; COMINO), reductions in mean CST were observed from baseline to week 24 with faricimab Q4W and were comparable to those seen with aflibercept Q4W. The mean CST reduction from baseline to week 24 was 311.4 μm for faricimab Q4W versus 304.4 μm for aflibercept Q4W, in BALATON, and 461.6 μm versus 448.8 μm in COMINO for faricimab and aflibercept, respectively. CST reductions were maintained through week 72 when patients moved to a faricimab up to Q16W adjustable dosing regimen.

Comparable proportions of patients in both faricimab Q4W and aflibercept Q4W arms achieved absence of IRF, absence of SRF, and absence of macular edema (defined as reaching CST below 325 μm) over time through week 24, in both studies. These results were maintained through week 72 when patients moved to a faricimab up to Q16W adjustable dosing regimen.

Clinical efficacy and safety

nAMD

The safety and efficacy of faricimab were assessed in two randomised, multi-centre, double-masked, active comparator-controlled, 2-year non-inferiority studies in patients with nAMD, TENAYA and LUCERNE. A total of 1 329 patients were enrolled, with 1 135 (85%) patients completing the studies through week 112. A total of 1 326 patients received at least one dose (664 with faricimab). Patient ages ranged from 50 to 99 years with a mean [standard deviation; SD] of 75.9 [8.6] years.

In both studies, patients were randomised in a 1:1 ratio to one of two treatment arms:

- Faricimab 6 mg up to Q16W after four initial monthly doses
- Aflibercept 2 mg Q8W after three initial monthly doses

After the first four monthly doses (weeks 0, 4, 8, and 12) patients randomised to the faricimab arm received Q16W, every 12 weeks (Q12W) or Q8W dosing based on an assessment of disease activity at weeks 20 and 24. Disease activity was assessed using objective pre-specified visual (BCVA) and anatomic (CST) criteria, as well as treating physician clinical assessment of the presence of macular haemorrhage or nAMD disease activity requiring treatment (week 24 only). Patients remained on these fixed dosing intervals until week 60 without supplemental therapy. From week 60 onwards, patients in the faricimab arm moved to an adjustable dosing regimen, where their treatment interval could be modified by up to 4 week interval extensions (up to Q16W) or reduced by up to 8 week intervals (up to Q8W) based on an automated objective assessment of pre-specified visual (BCVA) and anatomic (CST and macular haemorrhage) disease activity criteria. Patients in the aflibercept arm remained on Q8W dosing throughout the study period. Both studies were 112 weeks in duration.

Results

Both studies showed efficacy in the primary endpoint, defined as the mean change from baseline in BCVA when averaged over the week 40, 44, and 48 visits and measured by the Early Treatment Diabetic Retinopathy Study (ETDRS) letter score (Table 2 and Table 3). In both studies, faricimab up to Q16W treated patients had a non-inferior mean change from baseline in BCVA, as the patients treated with aflibercept Q8W at year 1, and these vision gains were maintained through week 112. Improvements from baseline BCVA at week 112 are shown in Figure 1.

The proportion of patients on each of the different treatment intervals at week 112 in TENAYA and LUCERNE, respectively was:

- Q16W: 59% and 67%
- Q12W: 15% and 14%
- Q8W: 26% and 19%

Table 2: Efficacy outcomes at the primary endpoint visits^a and at year 2^b in TENAYA

Efficacy Outcomes	TENAYA			
	Year 1		Year 2	
	Faricimab up to Q16W N = 334	Aflibercept Q8W N = 337	Faricimab up to Q16W N = 334	Aflibercept Q8W N = 337
Mean change in BCVA as measured by ETDRS letter score from baseline (95% CI)	5.8 (4.6, 7.1)	5.1 (3.9, 6.4)	3.7 (2.1, 5.4)	3.3 (1.7, 4.9)
Difference in LS mean (95% CI)	0.7 (-1.1, 2.5)		0.4 (-1.9, 2.8)	
Proportion of patients with ≥ 15 letter gain from baseline (CMH weighted proportion, 95% CI)	20.0% (15.6%, 24.4%)	15.7% (11.9%, 19.6%)	22.5% (17.8%, 27.2%)	16.9% (12.7%, 21.1%)
Difference in CMH weighted % (95% CI)	4.3% (-1.6%, 10.1%)		5.6% (-0.7%, 11.9%)	
Proportion of patients avoiding ≥ 15 letter loss from baseline (CMH weighted proportion, 95% CI)	95.4% (93.0%, 97.7%)	94.1% (91.5%, 96.7%)	92.1% (89.1%, 95.1%)	88.6% (85.1%, 92.2%)
Difference in CMH weighted % (95% CI)	1.3% (-2.2%, 4.8%)		3.4% (-1.2%, 8.1%)	

^aAverage of weeks 40, 44, and 48; ^bAverage of weeks 104, 108, 112

BCVA: Best Corrected Visual Acuity

ETDRS: Early Treatment Diabetic Retinopathy Study

CI: Confidence Interval

LS: Least Square

CMH: Cochran–Mantel–Haenszel method; a statistical test that generates an estimate of an association with a binary outcome and is used for assessment of categorical variables.

Table 3: Efficacy outcomes at the primary endpoint visits^a and at year 2^b in LUCERNE

Efficacy Outcomes	LUCERNE			
	Year 1		Year 2	
	Faricimab up to Q16W N = 331	Aflibercept Q8W N = 327	Faricimab up to Q16W N = 331	Aflibercept Q8W N = 327
Mean change in BCVA as measured by ETDRS letter score from baseline (95% CI)	6.6 (5.3, 7.8)	6.6 (5.3, 7.8)	5.0 (3.4, 6.6)	5.2 (3.6, 6.8)
Difference in LS mean (95% CI)	0.0 (-1.7, 1.8)		-0.2 (-2.4, 2.1)	
Proportion of patients with ≥ 15 letter gain from baseline (CMH weighted proportion, 95% CI)	20.2% (15.9%, 24.6%)	22.2% (17.7%, 26.8%)	22.4% (17.8%, 27.1%)	21.3% (16.8%, 25.9%)
Difference in CMH weighted % (95% CI)	-2.0% (-8.3%, 4.3%)		1.1% (-5.4%, 7.6%)	
Proportion of patients avoiding ≥ 15 letter loss from baseline (CMH weighted proportion, 95% CI)	95.8% (93.6%, 98.0%)	97.3% (95.5%, 99.1%)	92.9% (90.1%, 95.8%)	93.2% (90.2%, 96.2%)
Difference in CMH weighted % (95% CI)	-1.5% (-4.4%, 1.3%)		-0.2% (-4.4%, 3.9%)	

^aAverage of weeks 40, 44, and 48; ^bAverage of weeks 104, 108, 112

BCVA: Best Corrected Visual Acuity

ETDRS: Early Treatment Diabetic Retinopathy Study

CI: Confidence Interval

LS: Least Square

CMH: Cochran–Mantel–Haenszel method; a statistical test that generates an estimate of an association with a binary outcome and is used for assessment of categorical variables.

Figure 1: Mean change in visual acuity from baseline to year 2 (week 112); combined data from TENAYA and LUCERNE studies

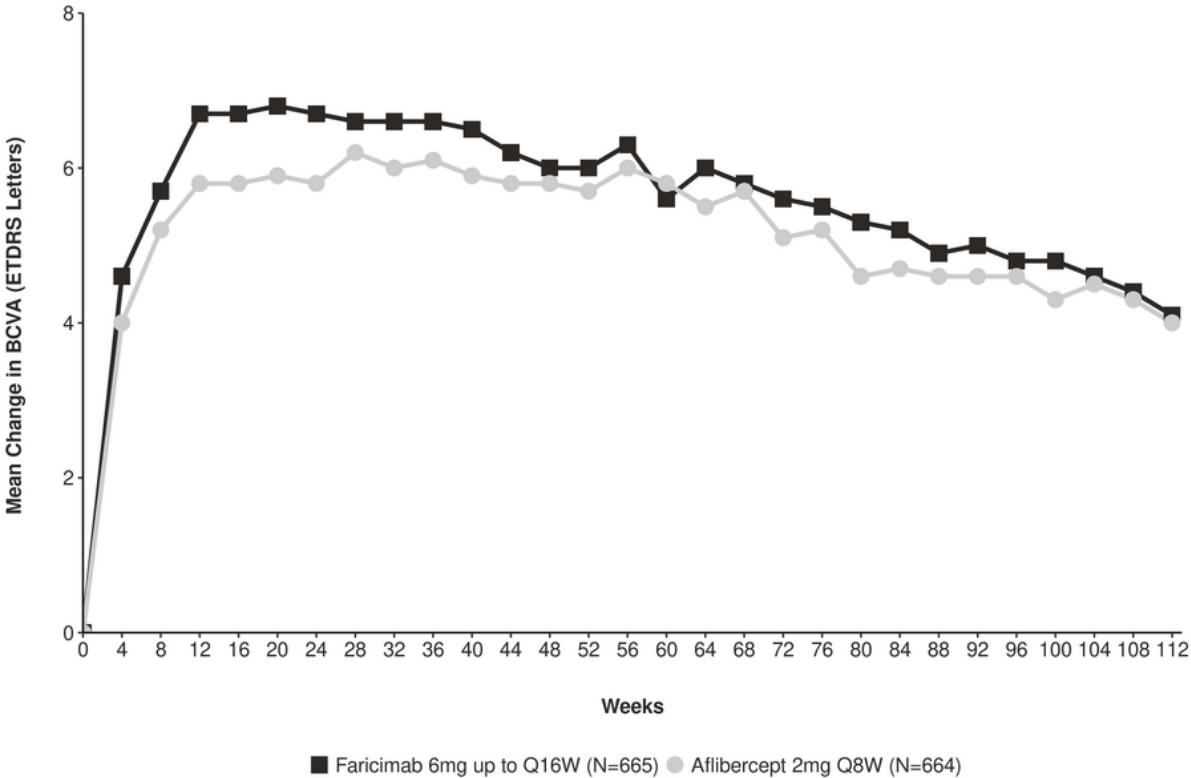

In both TENAYA and LUCERNE, improvements from baseline in BCVA and CST at week 60 were comparable across the two treatment arms and consistent with those seen at week 48.

At week 60, 46% of patients in both TENAYA and LUCERNE were on a Q16W interval. Of these, 69% of patients in both studies maintained Q16W through week 112 without interval reduction.

At week 60, 80% and 78% of patients in TENAYA and LUCERNE, respectively, were on a \geq Q12W interval (Q16W or Q12W). Of these, 67% and 75% of patients, respectively, maintained a \geq Q12W interval through week 112 without an interval reduction below Q12W.

At week 60, 33% of patients in both TENAYA and LUCERNE were on a Q12W interval. Of these, 3.2% and 0% of patients in TENAYA and LUCERNE, respectively, maintained Q12W through week 112.

At week 60, 20% and 22% of patients in TENAYA and LUCERNE, respectively, were on a Q8W interval. Of these, 34% and 30% of patients in TENAYA and LUCERNE, respectively, maintained Q8W therapy through week 112.

Efficacy results in all evaluable subgroups (e.g. age, gender, race, baseline visual acuity, lesion type, lesion size) in each study, and in the pooled analysis, were consistent with the results in the overall populations.

Across studies, faricimab up to Q16W showed improvement in pre-specified efficacy endpoint of mean change from baseline to week 48 in the National Eye Institute Visual Function Questionnaire (NEI VFQ-25) composite score that was comparable to aflibercept Q8W, and exceeded the threshold of 4 points. The magnitude of these changes corresponds to a 15-letter gain in BCVA.

The incidence of ocular adverse events in the study eye was 53.9% and 52.1% and non-ocular adverse events was 73.3% and 74.3%, through week 112 in the faricimab and aflibercept arms, respectively (see section 4.4 and 4.8).

DME

The safety and efficacy of faricimab were assessed in two randomised, multi-centre, double-masked, active comparator-controlled 2-year non-inferiority studies (YOSEMITE and RHINE) in patients with DME. A total of 1 891 patients were enrolled in the two studies with 1 622 (86%) patients completing the studies through week 100. A total of 1 887 patients were treated with at least one dose through week 56 (1 262 with faricimab). Patient ages ranged from 24 to 91 with a mean [SD] of 62.2 [9.9] years. The overall population included both anti-VEGF naive patients (78%) and patients who had been previously treated with a VEGF inhibitor prior to study participation (22%). In both studies, patients were randomised in a 1:1:1 ratio to one of the three treatment regimens:

- Faricimab 6 mg Q8W after the first 6 monthly doses.
- Faricimab 6 mg up to Q16W adjustable dosing administered in 4, 8, 12 or 16-week intervals after the first 4 monthly doses.
- Aflibercept 2 mg Q8W after the first 5 monthly doses.

In the Q16W adjustable dosing arm, the dosing followed a standardised treat-and-extend approach. The interval could be increased in 4-week increments or decreased in 4- or 8-week increments based on anatomic and/or visual outcomes, using data obtained only at study drug dosing visits.

Results

Both studies showed efficacy in the primary endpoint, defined as the mean change from baseline in BCVA at year 1 (average of the week 48, 52, and 56 visits), measured by the ETDRS Letter Score. In both studies, faricimab up to Q16W treated patients had a non-inferior mean change from baseline in BCVA, as the patients treated with aflibercept Q8W at year 1, and these vision gains were maintained through year 2.

After 4 initial monthly doses, the patients in the faricimab up to Q16W adjustable dosing arm could have received between the minimum of 6 and the maximum of 21 total injections through week 96. At week 52, 74% and 71% of patients in the faricimab up to Q16W adjustable dosing arm achieved a Q16W or Q12W dosing interval in YOSEMITE and RHINE, respectively (53% and 51% on Q16W, 21% and 20% on Q12W). Of these patients, 75% and 84% maintained \geq Q12W dosing without an interval reduction below Q12W through week 96; of the patients on Q16W at week 52, 70% and 82% of patients maintained Q16W dosing without an interval reduction through week 96 in YOSEMITE and RHINE, respectively. At week 96, 78% of patients in the faricimab up to Q16W adjustable dosing arm achieved a Q16W or Q12W dosing interval in both studies (60% and 64% on Q16W, 18% and 14% on Q12W). 4% and 6% of patients were extended to Q8W and stayed on \leq Q8W dosing intervals through week 96; 3% and 5% received only Q4W dosing in YOSEMITE and RHINE through week 96, respectively.

Detailed results from the analyses of YOSEMITE and RHINE studies are listed in Table 4, Table 5, and Figure 2 below.

Table 4: Efficacy outcomes at the year 1 primary endpoint visits^a and at year 2^b in YOSEMITE

Efficacy Outcomes	YOSEMITE					
	Year 1			Year 2		
	Faricimab Q8W N = 315	Faricimab up to Q16W adjustable dosing N = 313	Aflibercept Q8W N = 312	Faricimab Q8W N = 315	Faricimab up to Q16W adjustable dosing N = 313	Aflibercept Q8W N = 312
Mean change in BCVA as measured by ETDRS letter score from baseline (97.5% CI year 1 and 95% CI year 2)	10.7 (9.4, 12.0)	11.6 (10.3, 12.9)	10.9 (9.6, 12.2)	10.7 (9.4, 12.1)	10.7 (9.4, 12.1)	11.4 (10.0, 12.7)
Difference in LS mean (97.5% CI year 1, 95% CI year 2)	-0.2 (-2.0, 1.6)	0.7 (-1.1, 2.5)		-0.7 (-2.6, 1.2)	-0.7 (-2.5, 1.2)	
Proportion of patients who gained at least 15 letters in BCVA from baseline (CMH weighted proportion, 95% CI year 1 and year 2)	29.2% (23.9%, 34.5%)	35.5% (30.1%, 40.9%)	31.8% (26.6%, 37.0%)	37.2% (31.4%, 42.9%)	38.2% (32.8%, 43.7%)	37.4% (31.7%, 43.0%)
Difference in CMH weighted % (95% CI year 1 and year 2)	-2.6% (-10.0%, 4.9%)	3.5% (-4.0%, 11.1%)		-0.2% (-8.2%, 7.8%)	0.2% (-7.6%, 8.1%)	
Proportion of patients who avoided loss of at least 15 letters in BCVA from baseline (CMH weighted proportion, 95% CI year 1 and year 2)	98.1% (96.5%, 99.7%)	98.6% (97.2%, 100.0%)	98.9% (97.6%, 100.0%)	97.6% (95.7%, 99.5%)	97.8% (96.1%, 99.5%)	98.0% (96.2%, 99.7%)
Difference in CMH weighted % (95% CI year 1 and year 2)	-0.8% (-2.8%, 1.3%)	-0.3% (-2.2%, 1.5%)		-0.4% (-2.9%, 2.2%)	-0.2% (-2.6%, 2.2%)	

^aAverage of weeks 48, 52, 56; ^bAverage of weeks 92, 96, 100

BCVA: Best Corrected Visual Acuity

ETDRS: Early Treatment Diabetic Retinopathy Study

LS: Least Square

CI: Confidence Interval

CMH: Cochran–Mantel–Haenszel method; a statistical test that generates an estimate of an association with a binary outcome and is used for assessment of categorical variables.

Note: CMH weighted % for aflibercept arm presented for faricimab Q8W vs. aflibercept comparison, however the corresponding CMH weighted % for faricimab adjustable vs. aflibercept comparison is similar to the one shown above.

Table 5: Efficacy outcomes at the year 1 primary endpoint visits^a and at year 2^b in RHINE

Efficacy Outcomes	RHINE					
	Year 1			Year 2		
	Faricimab Q8W N = 317	Faricimab up to Q16W adjustable dosing N = 319	Aflibercept Q8W N = 315	Faricimab Q8W N = 317	Faricimab up to Q16W adjustable dosing N = 319	Aflibercept Q8W N = 315
Mean change in BCVA as measured by ETDRS letter score from baseline (97.5% CI year 1 and 95% CI year 2)	11.8 (10.6, 13.0)	10.8 (9.6, 11.9)	10.3 (9.1, 11.4)	10.9 (9.5, 12.3)	10.1 (8.7, 11.5)	9.4 (7.9, 10.8)
Difference in LS mean (97.5% CI year 1, 95% CI year 2)	1.5 (-0.1, 3.2)	0.5 (-1.1, 2.1)		1.5 (-0.5, 3.6)	0.7 (-1.3, 2.7)	
Proportion of patients who gained at least 15 letters in BCVA from baseline (CMH weighted proportion, 95% CI year 1 and year 2)	33.8% (28.4%, 39.2%)	28.5% (23.6%, 33.3%)	30.3% (25.0%, 35.5%)	39.8% (34.0%, 45.6%)	31.1% (26.1%, 36.1%)	39.0% (33.2%, 44.8%)
Difference in CMH weighted % (95% CI year 1 and year 2)	3.5% (-4.0%, 11.1%)	-2.0% (-9.1%, 5.2%)		0.8% (-7.4%, 9.0%)	-8% (-15.7%, -0.3%)	
Proportion of patients who avoided loss of at least 15 letters in BCVA from baseline (CMH weighted proportion, 95% CI year 1 and year 2)	98.9% (97.6%, 100.0%)	98.7% (97.4%, 100.0%)	98.6% (97.2%, 99.9%)	96.6% (94.4%, 98.8%)	96.8% (94.8%, 98.9%)	97.6% (95.7%, 99.5%)
Difference in CMH weighted % (95% CI year 1 and year 2)	0.3% (-1.6%, 2.1%)	0.0% (-1.8%, 1.9%)		-1.0% (-3.9%, 1.9%)	-0.7% (-3.5%, 2.0%)	

^aAverage of weeks 48, 52, 56; ^bAverage of weeks 92, 96, 100

BCVA: Best Corrected Visual Acuity

ETDRS: Early Treatment Diabetic Retinopathy Study

LS: Least Square

CI: Confidence Interval

CMH: Cochran–Mantel–Haenszel method; a statistical test that generates an estimate of an association with a binary outcome and is used for assessment of categorical variables.

Note: CMH weighted % for aflibercept arm presented for faricimab Q8W vs. aflibercept comparison, however the corresponding CMH weighted % for faricimab adjustable vs. aflibercept comparison is similar to the one shown above.

Figure 2: Mean change in visual acuity from baseline to year 2 (week 100); combined data from YOSEMITE and RHINE studies

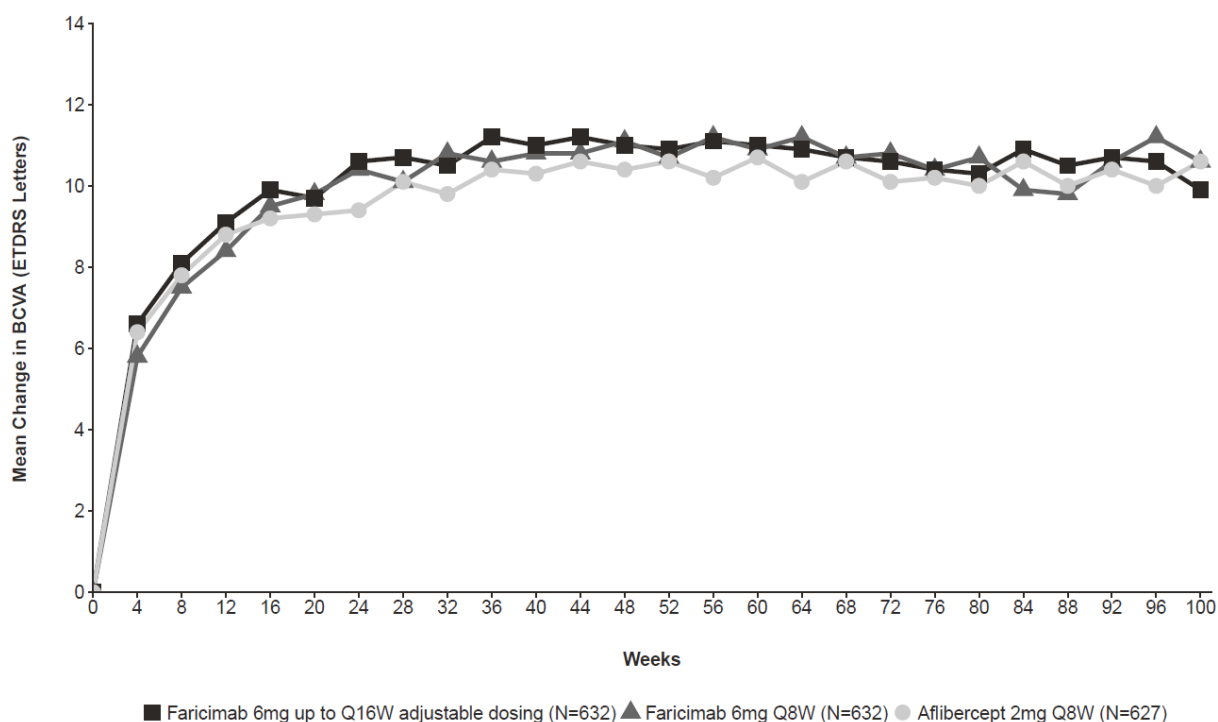

Efficacy results in patients who were anti-VEGF treatment naive prior to study participation and in all the other evaluable subgroups (e.g. by age, gender, race, baseline HbA1c, baseline visual acuity) in each study were consistent with the results in the overall populations.

Across studies, faricimab Q8W and up to Q16W adjustable dosing showed improvements in the pre-specified efficacy endpoint of mean change from baseline to week 52 in the NEI VFQ-25 composite score that was comparable to aflibercept Q8W and exceeded the threshold of 4 points. Faricimab Q8W and up to Q16W adjustable dosing also demonstrated clinically meaningful improvements in the pre-specified efficacy endpoint of change from baseline to week 52 in the NEI VFQ-25 near activities, distance activities, and driving scores, that were comparable to aflibercept Q8W. The magnitude of these changes corresponds to a 15-letter gain in BCVA. Comparable proportions of patients treated with faricimab Q8W, faricimab up to Q16W adjustable dosing, and aflibercept Q8W experienced a clinically meaningful improvement of ≥ 4 -points from baseline to week 52 in the NEI VFQ-25 composite score, a pre-specified efficacy endpoint. These results were maintained at week 100.

An additional key efficacy outcome in DME studies was the change in the Early Treatment Diabetic Retinopathy Study Diabetic Retinopathy Severity Scale (ETDRS-DRSS) from baseline to week 52. Of the 1 891 patients enrolled in Studies YOSEMITE and RHINE, 708 and 720 patients were evaluable for DR endpoints, respectively.

The ETDRS-DRSS scores ranged from 10 to 71 at baseline.

The majority of patients, approximately 60%, had moderate to severe non-proliferative DR (DRSS 43/47/53) at baseline.

The proportion of patients who achieved ≥ 2 -step and ≥ 3 -step improvement from baseline in ETDRS-DRSS at week 52 and at week 96 are shown in Table 6 and Table 7 below.

Table 6: Proportion of patients who achieved ≥ 2 -step and ≥ 3 -step improvement from baseline in ETDRS-DRSS score at week 52 and at week 96 in YOSEMITE (DR evaluable population)

	YOSEMITE					
	52 Weeks			96 Weeks		
	Faricimab Q8W n = 237	Faricimab up to Q16W adjustable dosing n = 242	Aflibercept Q8W n = 229	Faricimab Q8W n = 220	Faricimab up to Q16W adjustable dosing n = 234	Aflibercept Q8W n = 221
Proportion of patients with ≥ 2 -step ETDRS-DRSS improvement from baseline (CMH weighted proportion)	46.0%	42.5%	35.8%	51.4%	42.8%	42.2%
Weighted Difference (97.5% CI year 1, 95% year 2)	10.2% (0.3%, 20.0%)	6.1% (-3.6%, 15.8%)		9.1% (0.0%, 18.2%)	0.0% (-8.9%, 8.9%)	
Proportion of patients with ≥ 3 -step ETDRS-DRSS improvement from baseline (CMH weighted proportion)	16.8%	15.5%	14.7%	22.4%	14.6%	20.9%
Weighted Difference (95% CI year 1 and year 2)	2.1% (-4.3%, 8.6%)	0.6% (-5.8%, 6.9%)		1.5% (-6.0%, 9.0%)	-6.7% (-13.6%, 0.1%)	

ETDRS-DRSS: Early Treatment Diabetic Retinopathy Study Diabetic Retinopathy Severity Scale

CI: Confidence Interval

CMH: Cochran–Mantel–Haenszel method; a statistical test that generates an estimate of an association with a binary outcome and is used for assessment of categorical variables.

Note: CMH weighted % for aflibercept arm presented for faricimab Q8W vs. aflibercept comparison, however the corresponding CMH weighted % for faricimab adjustable vs. aflibercept comparison is similar to the one shown above.

Table 7: Proportion of patients who achieved ≥ 2 -step and ≥ 3 -step improvement from baseline in ETDRS-DRSS score at week 52 and at week 96 in RHINE (DR evaluable population)

	RHINE					
	52 Weeks			96 Weeks		
	Faricimab Q8W n = 231	Faricimab up to Q16W adjustable dosing n = 251	Aflibercept Q8W n = 238	Faricimab Q8W n = 214	Faricimab up to Q16W adjustable dosing n = 228	Aflibercept Q8W n = 203
Proportion of patients with ≥ 2 -step ETDRS-DRSS improvement from baseline (CMH weighted proportion)	44.2%	43.7%	46.8%	53.5%	44.3%	43.8%
Weighted Difference (97.5% CI year 1, 95% year 2)	-2.6% (-12.6%, 7.4%)	-3.5% (-13.4%, 6.3%)		9.7% (0.4%, 19.1%)	0.3% (-8.9%, 9.5%)	
Proportion of patients with ≥ 3 -step ETDRS-DRSS improvement from baseline (CMH weighted proportion)	16.7%	18.9%	19.4%	25.1%	19.3%	21.8%
Weighted Difference (95% CI year 1 and year 2)	-0.2% (-5.8%, 5.3%)	-1.1% (-8.0%, 5.9%)		3.3% (-4.6%, 11.3%)	-2.7% (-10.2%, 4.8%)	

ETDRS-DRSS: Early Treatment Diabetic Retinopathy Study Diabetic Retinopathy Severity Scale

CI: Confidence Interval

CMH: Cochran–Mantel–Haenszel method; a statistical test that generates an estimate of an association with a binary outcome and is used for assessment of categorical variables.

Note: CMH weighted % for aflibercept arm presented for faricimab Q8W vs. aflibercept comparison, however the corresponding CMH weighted % for faricimab adjustable vs. aflibercept comparison is similar to the one shown above.

Treatment effects in evaluable subgroups (e.g. by previous anti-VEGF treatment, age, gender, race, baseline HbA1c, and baseline visual acuity) in each study were generally consistent with the results in the overall population.

Treatment effects in subgroups by DR severity at baseline were different and showed the greatest ≥ 2 -step DRSS improvements among patients with moderately severe and severe non-proliferative DR with approximately 90% of patients achieving improvements consistently across all treatment arms in both studies.

The incidence of ocular adverse events in the study eye was 49.7%, 49.2%, and 45.4% and non-ocular adverse events was 73.0%, 74.2%, and 75.7% through week 100, in the faricimab Q8W, faricimab up to Q16W, and aflibercept Q8W arms, respectively (see section 4.4 and 4.8).

RV0

The safety and efficacy of faricimab were assessed in two randomised, multi-centre, double-masked, 72-week long studies in patients with macular oedema secondary to BRVO (BALATON) or CRVO/HRVO (COMINO). Active comparator-controlled data are available through month 6.

A total of 1 282 patients (553 in BALATON and 729 in COMINO) were enrolled in the two studies, with 1 276 patients treated with at least one dose through week 24 (641 with faricimab). Patient ages ranged from 28 to 93 with a mean [SD] of 64 [10.7] years, and 22 to 100 with a mean [SD] of 65 [13.2] years in BALATON and COMINO, respectively.

A total of 489 out of 553 patients randomised in BALATON completed the study at week 72; 263 patients initially randomised to faricimab ('prior faricimab') and 267 patients initially randomised to aflibercept ('prior aflibercept') received at least one dose of faricimab during the faricimab adjustable dosing phase.

A total of 656 out of 729 patients randomised in COMINO completed the study at week 72; 353 prior faricimab and 342 prior aflibercept patients received at least one dose of faricimab during the faricimab adjustable dosing phase.

In both studies, patients were randomised in a 1:1 ratio to one of two treatment arms until week 24:

- Faricimab 6 mg Q4W for 6 consecutive monthly doses
- Aflibercept 2 mg Q4W for 6 consecutive monthly doses

After 6 initial monthly doses, patients initially randomised to the aflibercept 2 mg arm moved to faricimab 6 mg, and could have received faricimab 6 mg up to Q16W adjustable dosing, where the dosing interval could be increased in 4-week increments or decreased by 4-, 8- or 12-weeks based on an automated objective assessment of pre-specified visual and anatomic disease activity criteria.

Results

Both studies showed efficacy in the primary endpoint, defined as the change from baseline in BCVA at week 24, measured by the ETDRS Letter Score. In both studies, faricimab Q4W treated patients had a non-inferior mean change from baseline in BCVA, compared to patients treated with aflibercept Q4W, and these vision gains were maintained through week 72 when patients moved to a faricimab up to Q16W adjustable dosing regimen.

Between week 24 and week 68, 81.5% and 74.0% of the patients receiving faricimab up to Q16W adjustable dosing regimen achieved a \geq Q12W (Q16W or Q12W) dosing interval in BALATON and COMINO, respectively. Of these patients, 72.1% and 61.6% completed at least one cycle of Q12W and maintained \geq Q12W dosing without an interval reduction below Q12W through week 68 in BALATON and COMINO, respectively; 1.2% and 2.5% of the patients received only Q4W dosing through week 68 in BALATON and COMINO, respectively.

Across studies, at week 24 patients in the faricimab Q4W arm showed improvement in the pre-specified efficacy endpoint of change from baseline to week 24 in the NEI VFQ-25 composite score that was comparable to aflibercept Q4W. Faricimab Q4W also demonstrated improvement in the pre-specified efficacy endpoint of change from baseline to week 24 in the NEI VFQ-25 near activities and distance activities, that were comparable to aflibercept Q4W. These results were maintained through week 72 when all patients were on faricimab up to Q16W adjustable dosing regimen.

Table 8: Efficacy outcomes at the week 24 primary endpoint visit and at the end of the study^a in BALATON

Efficacy Outcomes	BALATON			
	24 Weeks		72 Weeks ^a	
	Faricimab Q4W N = 276	Aflibercept Q4W N = 277	Faricimab Q4W to Faricimab Adjustable N = 276	Aflibercept Q4W to Faricimab Adjustable N = 277
Mean change in BCVA as measured by ETDRS letter score from baseline (95% CI)	16.9 (15.7, 18.1)	17.5 (16.3, 18.6)	18.1 (16.9, 19.4)	18.8 (17.5, 20.0)
Difference in LS mean (95% CI)	-0.6 (-2.2, 1.1)			
Proportion of patients with ≥ 15 letter gain from baseline (CMH weighted proportion, 95% CI)	56.1% (50.4%, 61.9%)	60.4% (54.7%, 66.0%)	61.5% (56.0%, 67.0%)	65.8% (60.3%, 71.2%)
Difference in CMH weighted % (95% CI)	-4.3% (-12.3%, 3.8%)			

^aAverage of weeks 64, 68, 72

BCVA: Best Corrected Visual Acuity

ETDRS: Early Treatment Diabetic Retinopathy Study

CI: Confidence Interval

LS: Least Square

CMH: Cochran–Mantel–Haenszel method; a statistical test that generates an estimate of an association with a binary outcome and is used for assessment of categorical variables.

Table 9: Efficacy outcomes at the week 24 primary endpoint visit and at the end of the study^a in COMINO

Efficacy Outcomes	COMINO			
	24 Weeks		72 Weeks ^a	
	Faricimab Q4W N = 366	Aflibercept Q4W N = 363	Faricimab Q4W to Faricimab Adjustable N = 366	Aflibercept Q4W to Faricimab Adjustable N = 363
Mean change in BCVA as measured by ETDRS letter score from baseline (95% CI)	16.9 (15.4, 18.3)	17.3 (15.9, 18.8)	16.9 (15.2, 18.6)	17.1 (15.4, 18.8)
Difference in LS mean (95% CI)	-0.4 (-2.5, 1.6)			
Proportion of patients with ≥ 15 letter gain from baseline (CMH weighted proportion, 95% CI)	56.6% (51.7%, 61.5%)	58.1% (53.3%, 62.9%)	57.6% (52.8%, 62.5%)	59.5% (54.7%, 64.3%)
Difference in CMH weighted % (95% CI)	-1.5% (-8.4%, 5.3%)			

^aAverage of weeks 64, 68, 72

BCVA: Best Corrected Visual Acuity

ETDRS: Early Treatment Diabetic Retinopathy Study

CI: Confidence Interval

LS: Least Square

CMH: Cochran–Mantel–Haenszel method; a statistical test that generates an estimate of an association with a binary outcome and is used for assessment of categorical variables.

Figure 3: Mean change in visual acuity from baseline to week 72 in BALATON

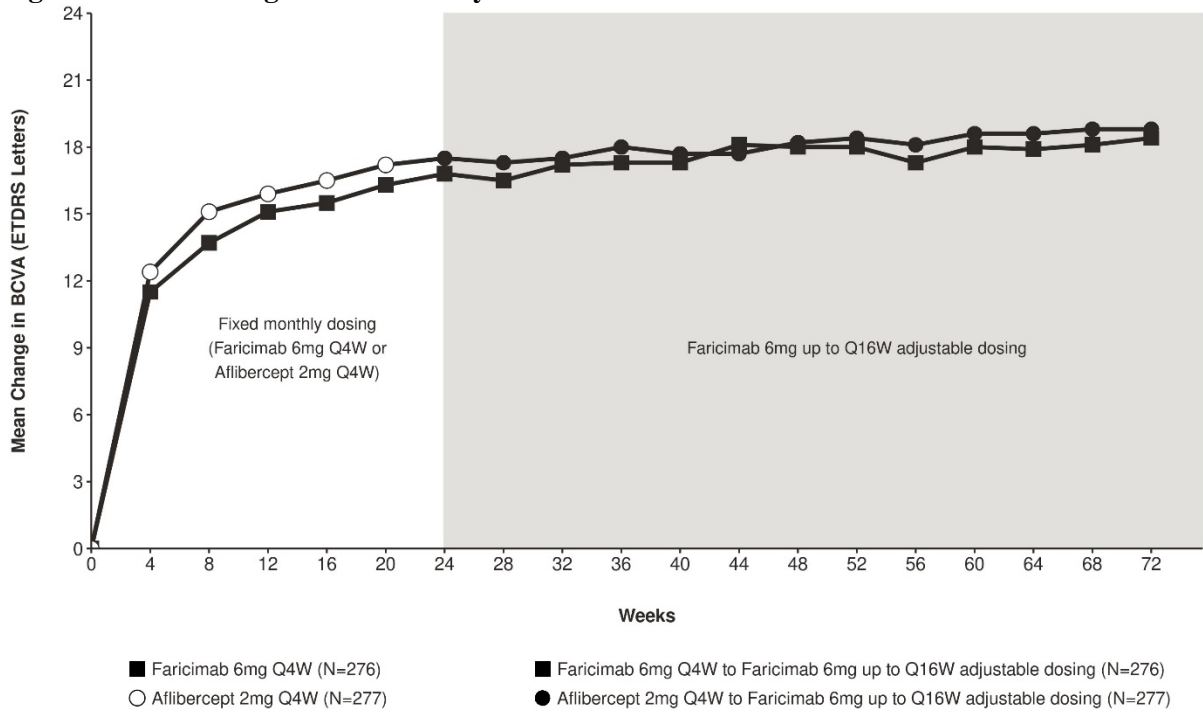

Faricimab 6 mg up to Q16W adjustable dosing started at week 24 but not all patients received faricimab at week 24.

Figure 4: Mean change in visual acuity from baseline to week 72 in COMINO

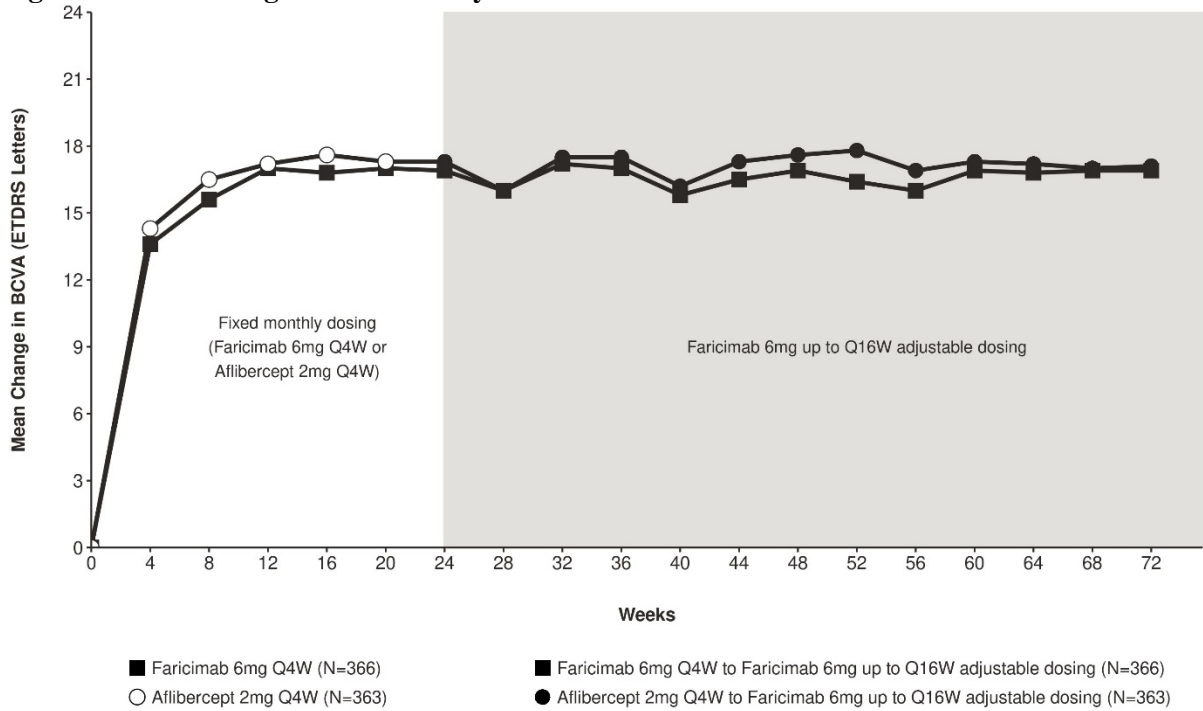

Faricimab 6 mg up to Q16W adjustable dosing started at week 24 but not all patients received faricimab at week 24.

The incidence of ocular adverse events in the study eye was 20.1% and 24.6%, and non-ocular adverse events was 32.9% and 36.4%, through week 24 in the faricimab Q4W and aflibercept Q4W arms, respectively (see section 4.8).

Paediatric population

The European Medicines Agency has waived the obligation to submit the results of studies with faricimab in all subsets of the paediatric population in nAMD, DME, and RVO (see section 4.2 for information on paediatric use).

5.2 Pharmacokinetic properties

Faricimab is administered intravitreally to exert local effects in the eye.

Absorption and distribution

Based on a population pharmacokinetic analysis (including nAMD and DME N = 2 246), maximum free (unbound to VEGF-A and Ang-2) faricimab plasma concentrations (C_{max}) are estimated to occur approximately 2 days post-dose. Mean (\pm SD [standard deviation]) plasma C_{max} are estimated 0.23 (0.07) μ g/mL and 0.22 (0.07) μ g/mL respectively in nAMD and in DME patients. After repeated administrations, mean plasma free faricimab trough concentrations are predicted to be 0.002-0.003 μ g/mL for Q8W dosing.

Faricimab exhibited dose-proportional pharmacokinetics (based on C_{max} and AUC) over the dose range 0.5 mg-6 mg. No accumulation of faricimab was apparent in the vitreous or in plasma following monthly dosing.

Maximum plasma free faricimab concentrations are predicted to be approximately 600 and 6 000-fold lower than in aqueous and vitreous humour respectively. Therefore, systemic pharmacodynamic effects are unlikely, further supported by the absence of significant changes in free VEGF and Ang-2 concentration in plasma upon faricimab treatment in clinical studies.

Population pharmacokinetic analysis has shown an effect of age and body weight on ocular or systemic pharmacokinetics of faricimab respectively. Both effects were considered not clinically meaningful; no dose adjustment is needed.

Biotransformation and elimination

Faricimab is a protein-based therapeutic hence its metabolism and elimination have not been fully characterised. Faricimab is expected to be catabolised in lysosomes to small peptides and amino acids, which may be excreted renally, in a similar manner to the elimination of endogenous IgG.

The faricimab plasma concentration-time profile declined in parallel with the vitreous and aqueous concentration-time profiles. The estimated mean ocular half-life and apparent systemic half-life of faricimab is approximately 7.5 days.

Pharmacokinetic analysis of patients with nAMD, DME, and RVO (N=2 977) has shown that the pharmacokinetics of faricimab are comparable in nAMD, DME, and RVO patients.

Special populations

Elderly

In the six Phase III clinical studies, approximately 58% (1,496/2,571) of patients randomised to treatment with faricimab were \geq 65 years of age. Population pharmacokinetic analysis has shown an effect of age on ocular pharmacokinetics of faricimab. The effect was considered not clinically meaningful. No dose adjustment is required in patients 65 years and above (see section 4.2).

Renal impairment

No specific studies in patients with renal impairment have been conducted with faricimab. Pharmacokinetic analysis of patients in all clinical studies of which 63% had renal impairment (mild 38%, moderate 23%, and severe 2%), revealed no differences with respect to systemic pharmacokinetics of faricimab after intravitreal administration of faricimab. No dose adjustment is required in patients with renal impairment (see section 4.2).

Hepatic impairment

No specific studies in patients with hepatic impairment have been conducted with faricimab. However, no special considerations are needed in this population because metabolism occurs via proteolysis and does not depend on hepatic function. No dose adjustment is required in patients with hepatic impairment (see section 4.2).

Other special populations

The systemic pharmacokinetics of faricimab are not influenced by race. Gender was not shown to have a clinically relevant influence on systemic pharmacokinetics of faricimab. No dose adjustment is needed.

5.3 Preclinical safety data

No studies have been conducted on the carcinogenic or mutagenic potential of faricimab.

In pregnant cynomolgus monkeys, intravenous injections of faricimab resulting in serum exposure (C_{max}) more than 500-times the maximum human exposure did not elicit developmental toxicity or teratogenicity, and had no effect on weight or structure of the placenta, although, based on its pharmacological effect faricimab should be regarded as potentially teratogenic and embryo-/foetotoxic.

Systemic exposure after ocular administration of faricimab is very low.

6. PHARMACEUTICAL PARTICULARS

6.1 List of excipients

L-histidine
Acetic acid 30% (for pH adjustment) (E 260)
L-methionine
Polysorbate 20 (E 432)
Sodium chloride
D-sucrose
Water for injections

6.2 Incompatibilities

In the absence of compatibility studies, this medicinal product must not be mixed with other medicinal products.

6.3 Shelf life

Pre-filled syringe: 2 years
Vial: 30 months

6.4 Special precautions for storage

Store in a refrigerator (2 °C - 8 °C).

Do not freeze.

Keep the vial in the outer carton in order to protect from light.

Keep the pre-filled syringe in the sealed tray in the original carton in order to protect from light.

Prior to use, the unopened pre-filled syringe or vial may be kept at room temperature, 20 °C to 25 °C, in the original carton, for up to 24 hours.

Ensure that the injection is given immediately after preparation of the dose.

6.5 Nature and contents of container

Pre-filled syringe

Solution for injection in a pre-filled syringe consisting of a glass barrel (type I) with a dose mark, a butyl rubber stopper, and a tamper-evident closure cap (including a rigid tip cap, a butyl rubber tip cap and a luer lock adapter). The container is assembled with a plunger rod and an extended finger grip. Each pre-filled syringe contains 21 mg faricimab in 0.175 mL solution.

Pack size of one sterile Extra Thin Wall injection filter needle (30-gauge × ½ inch, 0.30 mm x 12.7 mm, 5 µm), co-packed with one pre-filled syringe.

The rubber tip cap, the rubber stopper, the glass barrel and the injection filter needle are in contact with the medicinal product.

Vial

0.24 mL sterile, solution in a glass vial with a coated rubber stopper sealed with an aluminum cap with a yellow plastic flip-off disk.

Pack size of one vial and one blunt transfer filter needle (18-gauge x 1½ inch, 1.2 mm x 40 mm, 5 µm).

6.6 Special precautions for disposal and other handling

Do not shake.

Vabysmo should be inspected visually upon removal from the refrigerator and prior to administration. If particulates or cloudiness are visible, Vabysmo must not be used.

Pre-filled syringe

The pre-filled syringe is for single use in one eye only. Open the sterile pre-filled syringe under aseptic conditions only. The solution should be inspected visually prior to administration. If particulates or cloudiness are visible, the pre-filled syringe must not be used.

The pre-filled syringe contains more than the recommended dose of 6 mg faricimab (equivalent to 0.05 mL). Each pre-filled syringe contains 21 mg faricimab in 0.175 mL solution. The excess volume must be expelled prior to injection.

Do not use if the packaging, pre-filled syringe and/or injection filter needle are damaged or expired. Detailed instructions for use are provided in the package leaflet.

Vial

The vial contains more than the recommended dose of 6 mg. The fill volume of the vial (0.24 mL) is not to be used in total. The excess volume should be expelled prior to injection. Injecting the entire volume of the vial results in overdose. The injection dose must be set to the 0.05 mL dose mark, i.e. 6 mg faricimab.

The contents of the vial and the transfer filter needle are sterile and for single use only. Do not use if the packaging, vial and/or transfer filter needle are damaged or expired. Detailed instructions for use are provided in the package leaflet.

Any unused medicinal product or waste material should be disposed of in accordance with local requirements.

Instructions for use of pre-filled syringe:

Removal of the syringe from the syringe tray (step 1) and all subsequent steps should be done using aseptic technique.

Note: the dose must be set to the 0.05 mL dose mark.

Open tray and remove syringe cap

- 1 Peel the lid off the syringe tray and aseptically remove the pre-filled syringe.
- 2 Hold the syringe by the white collar; snap off the syringe cap (see **Figure C**).

Do not twist off the cap.

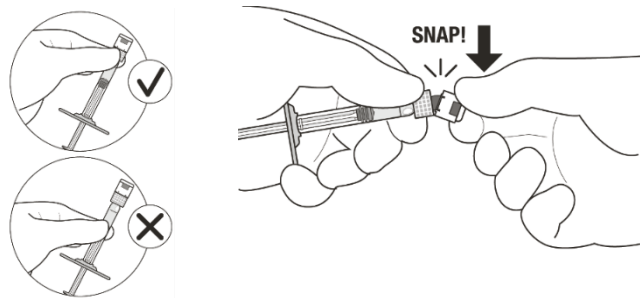

Figure C

Attach injection filter needle

- 3 Aseptically remove the injection filter needle from its packaging.
- 4 Aseptically and firmly attach the injection filter needle onto the syringe Luer lock (see **Figure D**).

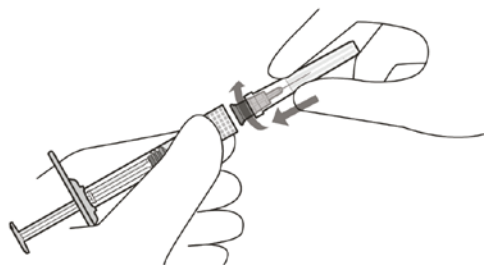

Figure D

Only use the provided injection filter needle for the administration

- 5 Carefully remove the needle cap by pulling it straight off.

Dislodge air bubbles

- 6 Hold the syringe with the injection filter needle pointing up. Check the syringe for air bubbles.
- 7 If there are any air bubbles, gently tap the syringe with your finger until the bubbles rise to the top (see **Figure E**).

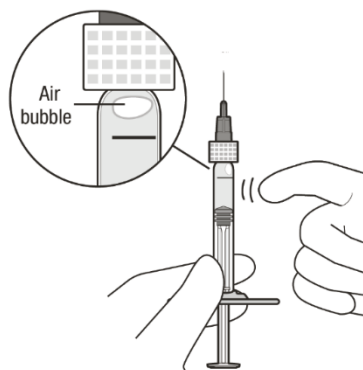

Figure E

Adjust medicinal product dose and expel air

- 8 Hold the syringe at eye level and **slowly** push the plunger rod until the **lower edge of the rubber stopper's dome** is aligned with the 0.05 mL dose mark (see **Figure F**). This will expel the air and the excess solution and set the dose to 0.05 mL.

Ensure that the injection is given **immediately** after preparation of the dose.

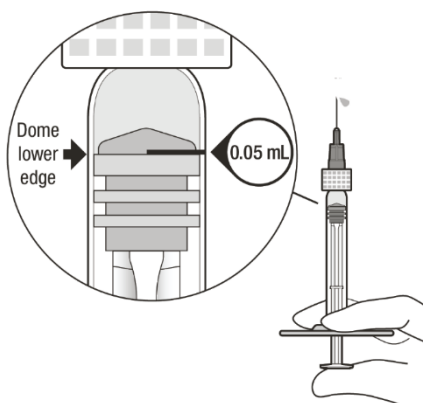

Figure F

Injection procedure

- 9 The injection procedure should be carried out under aseptic conditions.
Inject **slowly** until the rubber stopper reaches the bottom of the syringe to deliver the volume of 0.05 mL.
Do not recap or detach the injection filter needle from the syringe.
Any unused medicinal product or waste material should be disposed of in accordance with local regulations.

7. MARKETING AUTHORISATION HOLDER

Roche Registration GmbH
Emil-Barell-Strasse 1
79639 Grenzach-Wyhlen
Germany

8. MARKETING AUTHORISATION NUMBER(S)

EU/1/22/1683/001
EU/1/22/1683/002

9. DATE OF FIRST AUTHORISATION/RENEWAL OF THE AUTHORISATION

Date of first authorisation: 15 September 2022

10. DATE OF REVISION OF THE TEXT

Detailed information on this medicinal product is available on the website of the European Medicines Agency <https://www.ema.europa.eu/en>.

ANNEX II

- A. MANUFACTURER(S) OF THE BIOLOGICAL ACTIVE SUBSTANCE(S) AND MANUFACTURER(S) RESPONSIBLE FOR BATCH RELEASE**
- B. CONDITIONS OR RESTRICTIONS REGARDING SUPPLY AND USE**
- C. OTHER CONDITIONS AND REQUIREMENTS OF THE MARKETING AUTHORISATION**
- D. CONDITIONS OR RESTRICTIONS WITH REGARD TO THE SAFE AND EFFECTIVE USE OF THE MEDICINAL PRODUCT**

A. MANUFACTURER(S) OF THE BIOLOGICAL ACTIVE SUBSTANCE(S) AND MANUFACTURER(S) RESPONSIBLE FOR BATCH RELEASE

Name and address of the manufacturer(s) of the biological active substance(s)

Roche Diagnostics GmbH
Nonnenwald 2
82377 Penzberg
Germany

Name and address of the manufacturer(s) responsible for batch release

Roche Pharma AG
Emil-Barell-Strasse 1
79639 Grenzach-Wyhlen
Germany

B. CONDITIONS OR RESTRICTIONS REGARDING SUPPLY AND USE

Medicinal product subject to restricted medical prescription (see Annex I: Summary of Product Characteristics, section 4.2).

C. OTHER CONDITIONS AND REQUIREMENTS OF THE MARKETING AUTHORISATION

- **Periodic safety update reports (PSURs)**

The requirements for submission of PSURs for this medicinal product are set out in the list of Union reference dates (EURD list) provided for under Article 107c(7) of Directive 2001/83/EC and any subsequent updates published on the European medicines web-portal.

The marketing authorisation holder (MAH) shall submit the first PSUR for this medicinal product within 6 months following authorisation.

D. CONDITIONS OR RESTRICTIONS WITH REGARD TO THE SAFE AND EFFECTIVE USE OF THE MEDICINAL PRODUCT

- **Risk management plan (RMP)**

The marketing authorisation holder (MAH) shall perform the required pharmacovigilance activities and interventions detailed in the agreed RMP presented in Module 1.8.2 of the marketing authorisation and any agreed subsequent updates of the RMP.

An updated RMP should be submitted:

- At the request of the European Medicines Agency;
- Whenever the risk management system is modified, especially as the result of new information being received that may lead to a significant change to the benefit/risk profile or as the result of an important (pharmacovigilance or risk minimisation) milestone being reached.

- **Additional risk minimisation measures**

Prior to the launch of Vabysmo in each Member State the Marketing Authorisation Holder (MAH) must agree about the content and format of the educational programme, including communication media, distribution modalities, and any other aspects of the programme, with the National Competent Authority.

The educational programme is aimed at adequately informing patients/carers on the risks of Vabysmo, the key signs and symptoms of those risks, and when to seek urgent attention from their physician with the objective to minimize the risks and any resultant complications by encouraging prompt intervention.

The MAH shall ensure that in each Member State where Vabysmo is marketed, all patients/carers who are expected to use Vabysmo have access to/are provided with the following educational package:

- Patient information pack

The patient information pack consists of the patient information leaflet and a patient/carer guide. The patient guide is provided in written and audio format, and will include the following key elements:

- A description of neovascular age-related macular degeneration (nAMD), diabetic macular edema (DME), and retinal vein occlusion (RVO)
- A description of Vabysmo, how it works, and what to expect from Vabysmo treatment
- A description of the key signs and symptoms of the key risks associated with Vabysmo, i.e., infectious endophthalmitis and intraocular inflammation
- A description of when to seek urgent attention from the health care provider should signs and symptoms of these risks present themselves
- Recommendations for adequate care after the injection

ANNEX III
LABELLING AND PACKAGE LEAFLET

A. LABELLING

**PARTICULARS TO APPEAR ON THE OUTER PACKAGING
CARTON
PRE-FILLED SYRINGE**

1. NAME OF THE MEDICINAL PRODUCT

Vabysmo 120 mg/mL solution for injection in pre-filled syringe
faricimab

2. STATEMENT OF ACTIVE SUBSTANCE(S)

One mL of solution contains 120 mg of faricimab.
Each pre-filled syringe contains 21 mg faricimab in 0.175 mL solution.

3. LIST OF EXCIPIENTS

Also contains: L-histidine, acetic acid, L-methionine, polysorbate 20, sodium chloride, sucrose, water for injections.
See leaflet for further information

4. PHARMACEUTICAL FORM AND CONTENTS

Solution for injection
21 mg/0.175 mL
Delivers 1 single dose of 6 mg/0.05 mL

1 pre-filled syringe
1 injection filter needle

5. METHOD AND ROUTE(S) OF ADMINISTRATION

Intravitreal use
Single use only
Read the package leaflet before use
Upon opening of the sealed tray, proceed under aseptic conditions

Attention:
Only use the provided injection filter needle for the administration
The dose must be set to the 0.05 mL dose mark

6. SPECIAL WARNING THAT THE MEDICINAL PRODUCT MUST BE STORED OUT OF THE SIGHT AND REACH OF CHILDREN

Keep out of the sight and reach of children

7. OTHER SPECIAL WARNING(S), IF NECESSARY

8. EXPIRY DATE

EXP

9. SPECIAL STORAGE CONDITIONS

Store in a refrigerator
Do not freeze
Keep the sealed tray in the original carton to protect from light

10. SPECIAL PRECAUTIONS FOR DISPOSAL OF UNUSED MEDICINAL PRODUCTS OR WASTE MATERIALS DERIVED FROM SUCH MEDICINAL PRODUCTS, IF APPROPRIATE

11. NAME AND ADDRESS OF THE MARKETING AUTHORISATION HOLDER

Roche Registration GmbH
Emil-Barell-Strasse 1
79639 Grenzach-Wyhlen
Germany

12. MARKETING AUTHORISATION NUMBER(S)

EU/1/22/1683/002

13. BATCH NUMBER

Lot

14. GENERAL CLASSIFICATION FOR SUPPLY

15. INSTRUCTIONS ON USE

16. INFORMATION IN BRAILLE

Justification for not including Braille accepted.

17. UNIQUE IDENTIFIER – 2D BARCODE

2D barcode carrying the unique identifier included.

18. UNIQUE IDENTIFIER - HUMAN READABLE DATA

PC
SN
NN

**PARTICULARS TO APPEAR ON THE BLISTER FOIL
PRE-FILLED SYRINGE**

1. NAME OF THE MEDICINAL PRODUCT

Vabysmo 120 mg/mL solution for injection
faricimab

2. STATEMENT OF ACTIVE SUBSTANCE

3. LIST OF EXCIPIENTS

4. PHARMACEUTICAL FORM AND CONTENTS

21 mg/0.175 mL

5. METHOD AND ROUTE OF ADMINISTRATION

Single use only
Read the package leaflet before use
Intravitreal use
Only use the provided injection filter needle for the administration

**6. SPECIAL WARNING THAT THE MEDICINAL PRODUCT MUST BE STORED OUT
OF THE SIGHT AND REACH OF CHILDREN**

Keep out of the sight and reach of children.

7. OTHER SPECIAL WARNING(S), IF NECESSARY

8. EXPIRY DATE

EXP

9. SPECIAL STORAGE CONDITIONS

Store in a refrigerator
Do not freeze
Protect from light

10. SPECIAL PRECAUTIONS FOR DISPOSAL OF UNUSED MEDICINAL PRODUCTS OR WASTE MATERIALS DERIVED FROM SUCH MEDICINAL PRODUCTS, IF APPROPRIATE

11. NAME AND ADDRESS OF THE MARKETING AUTHORISATION HOLDER

Roche Registration GmbH
Emil-Barell-Strasse 1
79639 Grenzach-Wyhlen
Germany

12. MARKETING AUTHORISATION NUMBER(S)

EU/1/22/1683/002

13. BATCH NUMBER

Lot

14. GENERAL CLASSIFICATION FOR SUPPLY

15. INSTRUCTIONS ON USE

16. INFORMATION IN BRAILLE

**MINIMUM PARTICULARS TO APPEAR ON SMALL IMMEDIATE PACKAGING UNITS
PRE-FILLED SYRINGE**

1. NAME OF THE MEDICINAL PRODUCT AND ROUTE(S) OF ADMINISTRATION

Vabysmo 120 mg/mL injection
faricimab
Intravitreal use

2. METHOD OF ADMINISTRATION

3. EXPIRY DATE

EXP

4. BATCH NUMBER

Lot

5. CONTENTS BY WEIGHT, BY VOLUME OR BY UNIT

21 mg/0.175 mL

6. OTHER

**PARTICULARS TO APPEAR ON THE OUTER PACKAGING
CARTON
VIAL**

1. NAME OF THE MEDICINAL PRODUCT

Vabysmo 120 mg/mL solution for injection
faricimab

2. STATEMENT OF ACTIVE SUBSTANCE(S)

One mL of solution contains 120 mg of faricimab.
Each vial contains 28.8 mg faricimab (120 mg/mL).

3. LIST OF EXCIPIENTS

Also contains: L-histidine, acetic acid, L-methionine, polysorbate 20, sodium chloride, sucrose, water for injections.
See leaflet for further information

4. PHARMACEUTICAL FORM AND CONTENTS

Solution for injection
1 x 0.24 mL vial
1 filter needle

5. METHOD AND ROUTE(S) OF ADMINISTRATION

Single use only
Read the package leaflet before use
Intravitreal use
Single dose: 6 mg/0.05 mL
28.8 mg/0.24 mL

6. SPECIAL WARNING THAT THE MEDICINAL PRODUCT MUST BE STORED OUT OF THE SIGHT AND REACH OF CHILDREN

Keep out of the sight and reach of children.

7. OTHER SPECIAL WARNING(S), IF NECESSARY

8. EXPIRY DATE

EXP

9. SPECIAL STORAGE CONDITIONS

Store in a refrigerator
Do not freeze
Keep the vial in the outer carton in order to protect from light

10. SPECIAL PRECAUTIONS FOR DISPOSAL OF UNUSED MEDICINAL PRODUCTS OR WASTE MATERIALS DERIVED FROM SUCH MEDICINAL PRODUCTS, IF APPROPRIATE

11. NAME AND ADDRESS OF THE MARKETING AUTHORISATION HOLDER

Roche Registration GmbH
Emil-Barell-Strasse 1
79639 Grenzach-Wyhlen
Germany

12. MARKETING AUTHORISATION NUMBER(S)

EU/1/22/1683/001

13. BATCH NUMBER

Lot

14. GENERAL CLASSIFICATION FOR SUPPLY

15. INSTRUCTIONS ON USE

16. INFORMATION IN BRAILLE

Justification for not including Braille accepted.

17. UNIQUE IDENTIFIER – 2D BARCODE

2D barcode carrying the unique identifier included.

18. UNIQUE IDENTIFIER – HUMAN READABLE DATA

PC
SN
NN

**MINIMUM PARTICULARS TO APPEAR ON SMALL IMMEDIATE PACKAGING UNITS
VIAL**

1. NAME OF THE MEDICINAL PRODUCT AND ROUTE(S) OF ADMINISTRATION

Vabysmo 120 mg/mL solution for injection
faricimab
Intravitreal use

2. METHOD OF ADMINISTRATION

3. EXPIRY DATE

EXP

4. BATCH NUMBER

Lot

5. CONTENTS BY WEIGHT, BY VOLUME OR BY UNIT

28.8 mg/0.24 mL

6. OTHER

B. PACKAGE LEAFLET

Package leaflet: Information for the patient

Vabysmo 120 mg/mL solution for injection in pre-filled syringe faricimab

▼ This medicine is subject to additional monitoring. This will allow quick identification of new safety information. You can help by reporting any side effects you may get. See the end of section 4 for how to report side effects.

Read all of this leaflet carefully before you start using this medicine because it contains important information for you.

- Keep this leaflet. You may need to read it again.
- If you have any further questions, ask your doctor.
- If you get any side effects, talk to your doctor. This includes any possible side effects not listed in this leaflet. See section 4.

What is in this leaflet

1. What Vabysmo is and what it is used for
2. What you need to know before you receive Vabysmo
3. How to use Vabysmo
4. Possible side effects
5. How to store Vabysmo
6. Contents of the pack and other information

1. What Vabysmo is and what it is used for

What Vabysmo is and what it is used for

Vabysmo contains the active substance faricimab, which belongs to a group of medicines called antineovascularisation agents.

Vabysmo is injected into the eye by your doctor to treat eye disorders in adults called:

- neovascular (wet) age-related macular degeneration (nAMD),
- visual impairment due to diabetic macular oedema (DME),
- visual impairment due to macular oedema secondary to retinal vein occlusion (branch RVO or central RVO).

These disorders affect the macula, the central part of the retina (the light-sensitive layer at the back of the eye) that is responsible for fine, central vision. nAMD is caused by the growth of abnormal blood vessels which leak blood and fluid into the macula, and DME is caused by leaky blood vessels that cause swelling of the macula. Central RVO is the blockage of the main blood vessel (vein) that transports blood away from the retina, and branch RVO is the blockage of one of the smaller branches of the main blood vein. Due to the increased pressure within these blood vessels, there is leakage of fluid into the retina, causing swelling of the macula (macular edema).

How Vabysmo works

Vabysmo specifically recognises and blocks the activity of proteins known as angiopoietin-2 and vascular endothelial growth factor A. When these proteins are present at higher levels than normal, they can cause growth of abnormal blood vessels and/or damage to normal vessels, with leakage into the macula, causing swelling or damage that can negatively affect a person's vision. By attaching to these proteins, Vabysmo can block their actions and prevent abnormal vessel growth, leakage and

swelling. Vabysmo may improve the disease and/or slow down worsening of the disease and thereby maintain, or even improve, your vision.

2. What you need to know before you receive Vabysmo

You should not receive Vabysmo:

- if you are allergic to faricimab or any of the other ingredients of this medicine (listed in section 6).
- if you have an active or suspected infection in or around the eye.
- if you have pain or redness in your eye (eye inflammation).

If any of these apply to you, tell your doctor. You should not be given Vabysmo.

Warnings and precautions

Talk to your doctor before receiving Vabysmo:

- if you have glaucoma (an eye condition usually caused by high pressure in the eye).
- if you have a history of seeing flashes of light or floaters (dark floating spots) and if you have a sudden increase in the size and number of floaters.
- if you have had eye surgery in the last 4 weeks or if eye surgery is planned in the next four weeks.
- if you have ever had any eye diseases or eye treatments.

Tell your doctor immediately if you:

- develop sudden vision loss.
- develop signs of a possible eye infection or inflammation, such as increased redness of the eye, eye pain, increased eye discomfort, blurred or decreased vision, an increased number of small particles in your vision, increased sensitivity to light.

Furthermore it is important for you to know that:

- the safety and efficacy of Vabysmo when administered to both eyes at the same time has not been studied and use in this way may lead to an increased risk of side effects.
- injections with Vabysmo may cause a temporary increase in eye pressure (intraocular pressure) in some patients within 60minutes of the injection. Your doctor will monitor this after each injection.
- your doctor will check whether you have other risk factors that may increase the chance of a tear or detachment of one of the layers at the back of the eye (retinal detachment or tear, and retinal pigment epithelial detachment or tear), in which case Vabysmo must be given with caution.

When some medicines that work in a similar way to Vabysmo are given, there is known to be a risk of blood clots blocking blood vessels (arterial thromboembolic events), which may lead to heart attack or stroke. As small amounts of the medicine enter the blood, there is a theoretical risk of such events following injection of Vabysmo into the eye.

There is only limited experience in the treatment of:

- patients with active infections.
- patients with nAMD and RVO 85 years or older.
- patients with DME due to type I diabetes.
- diabetics with high average blood sugar values (Hb1Ac over 10%).
- diabetics with an eye disease caused by diabetes called proliferative diabetic retinopathy.
- diabetics with high blood pressure greater than 140/90 mmHg and disease of the blood vessels.
- patients with DME receiving injections less than every 8 weeks over a long period of time.

There is only limited experience in the treatment of patients receiving injections less than every 8 weeks over a long period of time, and these patients may be at greater risk of side effects.

There is no experience in the treatment of:

- diabetics or RVO patients with uncontrolled high blood pressure.

If any of the above applies to you, your doctor will consider this lack of information when treating you with Vabysmo.

Children and adolescents

The use of Vabysmo in children and adolescents has not been studied because nAMD, DME, and RVO occur mainly in adults.

Other medicines and Vabysmo

Tell your doctor if you are using, have recently used or might use any other medicines.

Pregnancy and breast-feeding

Vabysmo has not been studied in pregnant women. Vabysmo should not be used during pregnancy unless the potential benefit to the patient outweighs the potential risk to the unborn child.

If you are pregnant or breast-feeding, think you may be pregnant or are planning to have a baby, ask your doctor for advice before this medicine is given to you.

Breast-feeding is not recommended during treatment with Vabysmo because it is not known whether Vabysmo passes into human milk.

Women who could become pregnant must use an effective method of birth control during treatment and for at least three months after stopping treatment with Vabysmo. If you become pregnant or think you are pregnant during treatment, tell your doctor right away.

Driving and using machines

After your injection with Vabysmo, you may have temporary vision problems (for example blurred vision). Do not drive or use machines as long as these last.

Vabysmo contains sodium

The medicine contains less than 1mmol sodium (23 mg) per dose, that is to say essentially “sodium-free”.

Vabysmo contains polysorbate

This medicine contains 0.02 mg of polysorbate in each 0.05 mL dose. Polysorbates may cause allergic reactions. Tell your doctor that you have any known allergies.

3. How to use Vabysmo

How Vabysmo is given

The recommended dose is 6 mg of faricimab.

Neovascular (wet) age-related macular degeneration (nAMD)

- You will be treated with one injection every month for the first 3 months.

- After that, you may receive injections up to every 4 months. Your doctor will decide on the frequency of the injections based on the condition of your eye.
- Visual impairment due to diabetic macular oedema (DME) and macular oedema secondary to retinal vein occlusion (branch RVO or central RVO)
- You will be treated with one injection every month for a minimum of 3 months.
 - After that, you may receive injections less frequently. Your doctor will decide on the frequency of the injections based on the condition of your eye.

Method of administration

Vabysmo is injected into your eye (intravitreal injection) by a doctor experienced in giving eye injections.

Before the injection your doctor will use a disinfectant eyewash to clean your eye carefully to prevent infection. Your doctor will give you an eye drop (local anaesthetic) to numb the eye to reduce or prevent pain from the injection.

How long does Vabysmo treatment last for

This is a long-term treatment, possibly continuing for months or years. Your doctor will regularly monitor your condition to check that the treatment is working. Depending on how you respond to the treatment with Vabysmo, your doctor may ask you to change to a more or less frequent dose.

If you miss a dose of Vabysmo

If you miss a dose, schedule a new appointment with your doctor as soon as possible.

If you stop using Vabysmo

Speak with your doctor before stopping treatment. Stopping treatment may increase your risk of vision loss and your vision may worsen.

If you have any further questions on the use of this medicine, ask your doctor.

4. Possible side effects

Like all medicines, this medicine can cause side effects, although not everybody gets them.

The side effects with Vabysmo injection are either from the medicine itself or from the injection procedure and they mostly affect the eye.

Some side effects could be serious

Contact your doctor **immediately** if you have any of the following, which are signs of allergic reactions, inflammation or infections:

- eye pain, increased discomfort, increased eye redness, blurred or decreased vision, a higher number of small particles in your vision, or increased sensitivity to light – these are signs of a possible eye infection, inflammation, or allergic reaction.
- a sudden decrease or change in vision.

Other possible side effects

Other side effects which may occur after Vabysmo treatment include those listed below.

Most of the side effects are mild to moderate and will generally disappear within a week after each injection.

Contact your doctor if any of the following side effects become severe.

Very common (may affect more than 1 in 10 people):

- None

Common (may affect up to 1 in 10 people):

- Cloudy lens in the eye (cataract)
- Tear of one of the layers in the back of the eye (retinal pigment epithelial tear — nAMD only)
- Detachment of the gel-like substance inside the eye (vitreous detachment)
- Increase in pressure inside the eye (increased intraocular pressure)
- Bleeding from small blood vessels in the outer layer of the eye (conjunctival haemorrhage)
- Moving spots or dark shapes in your vision (vitreous floaters)
- Eye pain

Uncommon (may affect up to 1 in 100 people):

- Serious inflammation or infection inside the eye (endophthalmitis)
- Inflammation of the gel-like substance inside the eye/red eye (vitritis)
- Inflammation in the iris and its adjacent tissue in the eye (iritis, iridocyclitis, uveitis)
- Bleeding inside the eye (vitreous haemorrhage)
- Eye discomfort
- Itching (eye pruritus)
- Tearing of the retina (the back of the eye that detects light)
- Red eye (ocular/conjunctival hyperaemia)
- A feeling of having something in the eye
- Blurred vision
- Decreased sharpness of vision (visual acuity reduced)
- Pain during the procedure (procedural pain)
- Detachment of the retina
- Increased tear production (increased lacrimation)
- Scratched cornea, damage to the clear layer of the eyeball that covers the iris (corneal abrasion)
- Eye irritation

Rare (may affect up to 1 in 1 000 people):

- Temporary decreased sharpness of vision (visual acuity reduced transiently)
- Clouding of the lens due to injury (traumatic cataract)

Not known

- Retinal vasculitis (inflammation of blood vessels in the back of the eye)
- Retinal occlusive vasculitis (blockage of blood vessels in the back of the eye, typically in presence of inflammation)

When some medicines that work in a similar way to Vabysmo are given, there is known to be a risk of blood clots blocking blood vessels (arterial thromboembolic events), which may lead to heart attack or stroke. As small amounts of the medicine enter the blood, there is a theoretical risk of such events following injection of Vabysmo into the eye.

Reporting of side effects

If you get any side effects, talk to your doctor. This includes any possible side effects not listed in this leaflet. You can also report side effects directly via [the national reporting system listed in Appendix V](#). By reporting side effects you can help provide more information on the safety of this medicine.

5. How to store Vabysmo

Your doctor, pharmacist or nurse is responsible for storing this medicine and disposing of any unused product correctly. The following information is intended for healthcare professionals.

Keep this medicine out of the sight and reach of children.

Do not use this medicine after the expiry date which is stated on the carton and label after EXP. The expiry date refers to the last day of that month.

Store in a refrigerator (2 °C – 8 °C).

Do not freeze.

Keep the sealed tray in the original carton to protect the pre-filled syringe from light.

The pre-filled syringe may be kept at room temperature, 20 °C to 25 °C, in the original carton for up to 24 hours.

6. Contents of the pack and other information

What Vabysmo contains

- The active substance is faricimab. One mL solution for injection contains 120 mg faricimab. Each pre-filled syringe contains 21 mg faricimab in 0.175 mL solution. This provides a usable amount to deliver a single dose of 0.05 mL solution containing 6 mg of faricimab.
- The other ingredients are: L-histidine, acetic acid 30% (E 260), L-methionine, sodium chloride, sucrose, polysorbate 20 (E 432), water for injections (see Section 2 “Vabysmo contains sodium and polysorbate”).

What Vabysmo looks like and contents of the pack

Vabysmo 120 mg/mL solution for injection (injection) in a pre-filled syringe, is a clear to opalescent, colourless to brownish-yellow solution.

Pack size of one sterile Extra Thin Wall injection filter needle (30-gauge x ½ inch, 0.30 mm x 12.7 mm, 5 µm), co-packed with one pre-filled syringe for single-use only.

Marketing Authorisation Holder

Roche Registration GmbH
Emil-Barell-Strasse 1
79639 Grenzach-Wyhlen
Germany

Manufacturer

Roche Pharma AG
Emil-Barell-Str 1
79639 Grenzach-Wyhlen
Germany

For any information about this medicine, please contact the local representative of the Marketing Authorisation Holder:

België/Belgique/Belgien

N.V. Roche S.A.

Tél/Tel: +32 (0) 2 525 82 11

България

Рош България ЕООД

Тел: +359 2 474 5444

Česká republika

Roche s. r. o.

Tel: +420 - 2 20382111

Danmark

Roche Pharmaceuticals A/S

Tlf: +45 - 36 39 99 99

Deutschland

Roche Pharma AG

Tel: +49 (0) 7624 140

Eesti

Roche Eesti OÜ

Tel: + 372 - 6 177 380

Ελλάδα

Roche (Hellas) A.E.

Τηλ: +30 210 61 66 100

España

Roche Farma S.A.

Tel: +34 - 91 324 81 00

France

Roche

Tél: +33 (0)1 47 61 40 00

Hrvatska

Roche d.o.o.

Tel: + 385 1 47 22 333

Ireland

Roche Products (Ireland) Ltd.

Tel: +353 (0) 1 469 0700

Ísland

Roche Pharmaceuticals A/S

c/o Icepharma hf

Sími: +354 540 8000

Italia

Roche S.p.A.

Tel: +39 - 039 2471

Lietuva

UAB "Roche Lietuva"

Tel: +370 5 2546799

Luxembourg/Luxemburg

(Voir/siehe Belgique/Belgien)

Magyarország

Roche (Magyarország) Kft.

Tel: +36 - 1 279 4500

Malta

(See Ireland)

Nederland

Roche Nederland B.V.

Tel: +31 (0) 348 438050

Norge

Roche Norge AS

Tlf: +47 - 22 78 90 00

Österreich

Roche Austria GmbH

Tel: +43 (0) 1 27739

Polska

Roche Polska Sp.z o.o.

Tel: +48 - 22 345 18 88.

Portugal

Roche Farmacêutica Química, Lda

Tel: +351 - 21 425 70 00

România

Roche România S.R.L.

Tel: +40 21 206 47 01

Slovenija

Roche farmacevtska družba d.o.o.

Tel: +386 - 1 360 26 00

Slovenská republika

Roche Slovensko, s.r.o.

Tel: +421 - 2 52638201

Suomi/Finland

Roche Oy

Puh/Tel: +358 (0) 10 554 500

Κύπρος

Roche (Hellas) A.E.

Τηλ: +30 210 61 66 100

Sverige

Roche AB

Tel: +46 (0) 8 726 1200

Latvija

Roche Latvija SIA

Tel: +371 - 6 7039831

This leaflet was last revised in

Detailed information on this medicine is available on the European Medicines Agency web site:

<https://www.ema.europa.eu>.

<----->

The following information is intended for healthcare professionals only:

Instructions for use of pre-filled syringe:

Before you start



Read all the instructions carefully before using Vabysmo.

The Vabysmo carton includes:



A sterile pre-filled syringe in a sealed tray. The pre-filled syringe is for a single dose only.



A sterile, 30-gauge x ½ inch, ETW (Extra Thin Wall) injection filter needle with an integrated filter in the hub. The injection filter needle is for single use only.

Only use the provided injection filter needle for the administration,
as it was designed to ensure safe ophthalmic use of the medicinal product.



Vabysmo should be refrigerated at temperatures between 2°C to 8°C .

Do not freeze.



Allow Vabysmo to reach room temperature, 20°C to 25°C before proceeding with the administration.



Prior to use, keep the sealed tray in the original carton to **protect the pre-filled syringe from light**. The pre-filled syringe may be kept at room temperature in the original carton for up to **24 hours**.



Vabysmo should be inspected visually prior to administration.

Do not use if the carton seals have been tampered with.

Do not use if the packaging, pre-filled syringe, injection filter needle is expired, damaged, or have been tampered with.

Do not use if the injection filter needle is missing.

Do not remove the finger grip from the syringe.

Do not use if the syringe cap is detached from the Luer lock.

Do not use if particulates, cloudiness, or discolouration are visible. Vabysmo is a clear to opalescent and colourless to brownish-yellow liquid solution.

Carton contents

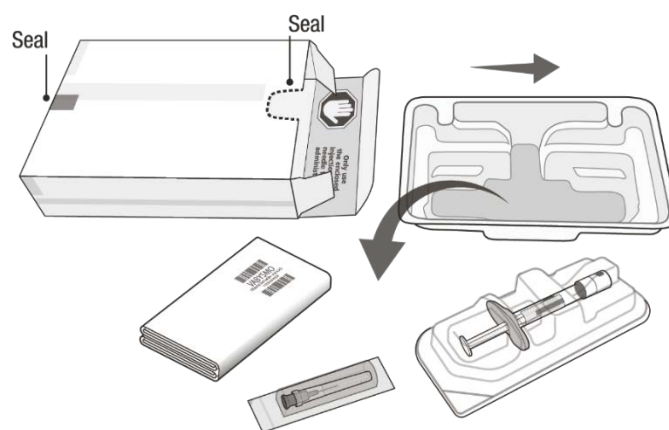

Figure A

Device description

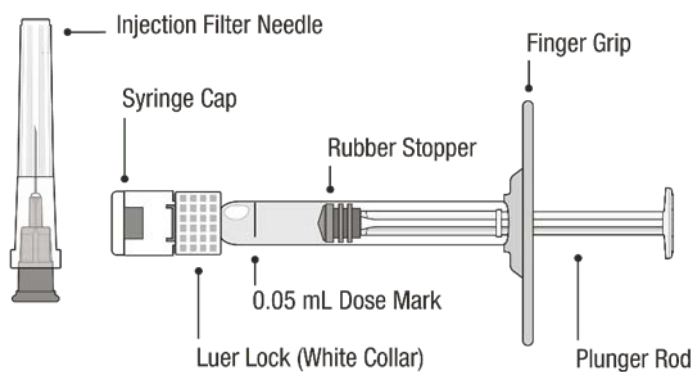

Figure B

Removal of the syringe from the syringe tray (step 1) and all subsequent steps should be done using aseptic technique.

Open tray and remove syringe cap

- 1 Peel the lid off the syringe tray and aseptically remove the pre-filled syringe.
- 2 Hold the syringe by the white collar; snap off the syringe cap (see **Figure C**).

Do not twist off the cap.

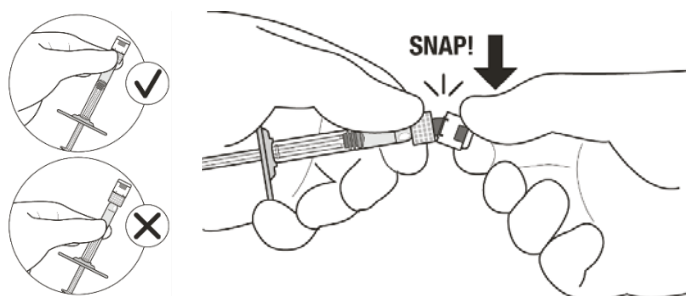
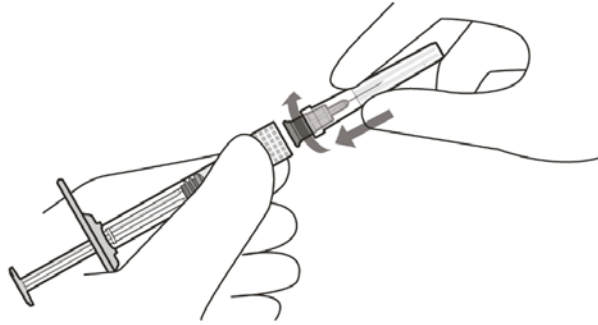

Figure C

Attach injection filter needle

- 3 Aseptically remove the injection filter needle from its packaging.
- 4 Aseptically and firmly attach the injection filter needle onto the syringe Luer lock (see **Figure D**).



Only use the provided injection filter needle for the administration

Figure D

- 5 Carefully remove the needle cap by pulling it straight off.

Dislodge air bubbles

- 6 Hold the syringe with the injection filter needle pointing up. Check the syringe for air bubbles.
- 7 If there are any air bubbles, gently tap the syringe with your finger until the bubbles rise to the top (see **Figure E**).

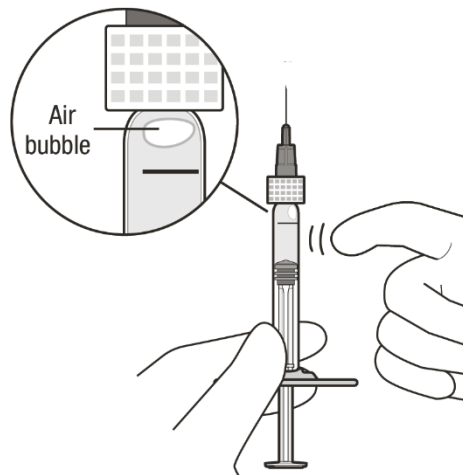

Figure E

Adjust medicinal product dose and expel air

- 8 Hold the syringe at eye level and **slowly** push the plunger rod until the **lower edge of the rubber stopper's dome** is aligned with the 0.05 mL dose mark (see **Figure F**). This will expel the air and the excess solution and set the dose to 0.05 mL.

Ensure that the injection is given **immediately** after preparation of the dose.

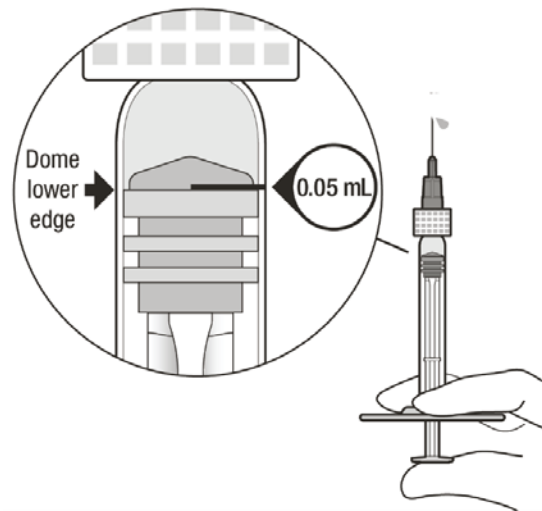

Figure F

Injection procedure

- 9 The injection procedure should be carried out under aseptic conditions.

Inject **slowly** until the rubber stopper reaches the bottom of the syringe to deliver the volume of 0.05 mL.

Do not recap or detach the injection filter needle from the syringe.

Any unused medicinal product or waste material should be disposed of in accordance with local regulations.

Package leaflet: Information for the patient

Vabysmo 120 mg/mL solution for injection faricimab

▼ This medicine is subject to additional monitoring. This will allow quick identification of new safety information. You can help by reporting any side effects you may get. See the end of section 4 for how to report side effects.

Read all of this leaflet carefully before you start using this medicine because it contains important information for you.

- Keep this leaflet. You may need to read it again.
- If you have any further questions, ask your doctor.
- If you get any side effects, talk to your doctor. This includes any possible side effects not listed in this leaflet. See section 4.

What is in this leaflet

1. What Vabysmo is and what it is used for
2. What you need to know before you receive Vabysmo
3. How to use Vabysmo
4. Possible side effects
5. How to store Vabysmo
6. Contents of the pack and other information

1. What Vabysmo is and what it is used for

What Vabysmo is and what it is used for

Vabysmo contains the active substance faricimab, which belongs to a group of medicines called antineovascularisation agents.

Vabysmo is injected into the eye by your doctor to treat eye disorders in adults called:

- neovascular (wet) age-related macular degeneration (nAMD),
- visual impairment due to diabetic macular oedema (DME),
- visual impairment due to macular oedema secondary to retinal vein occlusion (branch RVO or central RVO).

These disorders affect the macula, the central part of the retina (the light-sensitive layer at the back of the eye) that is responsible for fine, central vision. nAMD is caused by the growth of abnormal blood vessels which leak blood and fluid into the macula, and DME is caused by leaky blood vessels that cause swelling of the macula. Central RVO is the blockage of the main blood vessel (vein) that transports blood away from the retina, and branch RVO is the blockage of one of the smaller branches of the main blood vein. Due to the increased pressure within these blood vessels, there is leakage of fluid into the retina, causing swelling of the macula (macular edema).

How Vabysmo works

Vabysmo specifically recognises and blocks the activity of proteins known as angiopoietin-2 and vascular endothelial growth factor A. When these proteins are present at higher levels than normal, they can cause growth of abnormal blood vessels and/or damage to normal vessels, with leakage into the macula, causing swelling or damage that can negatively affect a person's vision. By attaching to these proteins, Vabysmo can block their actions and prevent abnormal vessel growth, leakage and swelling. Vabysmo may improve the disease and/or slow down worsening of the disease and thereby maintain, or even improve, your vision.

2. What you need to know before you receive Vabysmo

You should not receive Vabysmo:

- if you are allergic to faricimab or any of the other ingredients of this medicine (listed in section 6).
- if you have an active or suspected infection in or around the eye.
- if you have pain or redness in your eye (eye inflammation).

If any of these apply to you, tell your doctor. You should not be given Vabysmo.

Warnings and precautions

Talk to your doctor before receiving Vabysmo:

- if you have glaucoma (an eye condition usually caused by high pressure in the eye).
- if you have a history of seeing flashes of light or floaters (dark floating spots) and if you have a sudden increase in the size and number of floaters.
- if you have had eye surgery in the last 4 weeks or if eye surgery is planned in the next 4 weeks.
- if you have ever had any eye diseases or eye treatments.

Tell your doctor immediately if you:

- develop sudden vision loss.
- develop signs of a possible eye infection or inflammation, such as increased redness of the eye, eye pain, increased eye discomfort, blurred or decreased vision, an increased number of small particles in your vision, increased sensitivity to light.

Furthermore it is important for you to know that:

- the safety and efficacy of Vabysmo when administered to both eyes at the same time has not been studied and use in this way may lead to an increased risk of side effects.
- injections with Vabysmo may cause a temporary increase in eye pressure (intraocular pressure) in some patients within 60 minutes of the injection. Your doctor will monitor this after each injection.
- your doctor will check whether you have other risk factors that may increase the chance of a tear or detachment of one of the layers at the back of the eye (retinal detachment or tear, and retinal pigment epithelial detachment or tear), in which case Vabysmo must be given with caution.

When some medicines that work in a similar way to Vabysmo are given, there is known to be a risk of blood clots blocking blood vessels (arterial thromboembolic events), which may lead to heart attack or stroke. As small amounts of the medicine enter the blood, there is a theoretical risk of such events following injection of Vabysmo into the eye.

There is only limited experience in the treatment of:

- patients with active infections.
- patients with nAMD and RVO 85 years or older.
- patients with DME due to type I diabetes.
- diabetics with high average blood sugar values (Hb1Ac over 10%).
- diabetics with an eye disease caused by diabetes called proliferative diabetic retinopathy.
- diabetics with high blood pressure greater than 140/90 mmHg and disease of the blood vessels.
- patients with DME receiving injections less than every 8 weeks over a long period of time.

There is only limited experience in the treatment of patients receiving injections less than every 8 weeks over a long period of time, and these patients may be at greater risk of side effects.

There is no experience in the treatment of:

- diabetics or RVO patients with uncontrolled high blood pressure.

If any of the above applies to you, your doctor will consider this lack of information when treating you with Vabysmo.

Children and adolescents

The use of Vabysmo in children and adolescents has not been studied because nAMD, DME, and RVO occur mainly in adults.

Other medicines and Vabysmo

Tell your doctor if you are using, have recently used or might use any other medicines.

Pregnancy and breast-feeding

Vabysmo has not been studied in pregnant women. Vabysmo should not be used during pregnancy unless the potential benefit to the patient outweighs the potential risk to the unborn child.

If you are pregnant or breast-feeding, think you may be pregnant or are planning to have a baby, ask your doctor for advice before this medicine is given to you.

Breast-feeding is not recommended during treatment with Vabysmo because it is not known whether Vabysmo passes into human milk.

Women who could become pregnant must use an effective method of birth control during treatment and for at least three months after stopping treatment with Vabysmo. If you become pregnant or think you are pregnant during treatment, tell your doctor right away.

Driving and using machines

After your injection with Vabysmo, you may have temporary vision problems (for example blurred vision). Do not drive or use machines as long as these last.

Vabysmo contains sodium

The medicine contains less than 1 mmol sodium (23 mg) per dose, that is to say essentially “sodium-free”.

Vabysmo contains polysorbate

This medicine contains 0.02 mg of polysorbate in each 0.05 mL dose. Polysorbates may cause allergic reactions. Tell your doctor that you have any known allergies.

3. How to use Vabysmo

How Vabysmo is given

The recommended dose is 6 mg of faricimab.

Neovascular (wet) age-related macular degeneration (nAMD)

- You will be treated with one injection every month for the first 3 months.
- After that, you may receive injections up to every 4 months. Your doctor will decide on the frequency of the injections based on the condition of your eye.

Visual impairment due to diabetic macular oedema (DME) and macular oedema secondary to retinal vein occlusion (branch RVO or central RVO)

- You will be treated with one injection every month for a minimum of 3 months.

- After that, you may receive injections less frequently. Your doctor will decide on the frequency of the injections based on the condition of your eye.

Method of administration

Vabysmo is injected into your eye (intravitreal injection) by a doctor experienced in giving eye injections.

Before the injection your doctor will use a disinfectant eyewash to clean your eye carefully to prevent infection. Your doctor will give you an eye drop (local anaesthetic) to numb the eye to reduce or prevent pain from the injection.

How long does Vabysmo treatment last for

This is a long-term treatment, possibly continuing for months or years. Your doctor will regularly monitor your condition to check that the treatment is working. Depending on how you respond to the treatment with Vabysmo, your doctor may ask you to change to a more or less frequent dose.

If you miss a dose of Vabysmo

If you miss a dose, schedule a new appointment with your doctor as soon as possible.

If you stop using Vabysmo

Speak with your doctor before stopping treatment. Stopping treatment may increase your risk of vision loss and your vision may worsen.

If you have any further questions on the use of this medicine, ask your doctor.

4. Possible side effects

Like all medicines, this medicine can cause side effects, although not everybody gets them.

The side effects with Vabysmo injection are either from the medicine itself or from the injection procedure and they mostly affect the eye.

Some side effects could be serious

Contact your doctor **immediately** if you have any of the following, which are signs of allergic reactions, inflammation or infections:

- eye pain, increased discomfort, increased eye redness, blurred or decreased vision, a higher number of small particles in your vision, or increased sensitivity to light – these are signs of a possible eye infection, inflammation, or allergic reaction.
- a sudden decrease or change in vision.

Other possible side effects

Other side effects which may occur after Vabysmo treatment include those listed below.

Most of the side effects are mild to moderate and will generally disappear within a week after each injection.

Contact your doctor if any of the following side effects become severe.

Very common (may affect more than 1 in 10 people):

- None

Common (may affect up to 1 in 10 people):

- Cloudy lens in the eye (cataract)
- Tear of one of the layers in the back of the eye (retinal pigment epithelial tear – nAMD only)
- Detachment of the gel-like substance inside the eye (vitreous detachment)
- Increase in pressure inside the eye (increased intraocular pressure)
- Bleeding from small blood vessels in the outer layer of the eye (conjunctival haemorrhage)
- Moving spots or dark shapes in your vision (vitreous floaters)
- Eye pain

Uncommon (may affect up to 1 in 100 people):

- Serious inflammation or infection inside the eye (endophthalmitis)
- Inflammation of the gel-like substance inside the eye/red eye (vitritis)
- Inflammation in the iris and its adjacent tissue in the eye (iritis, iridocyclitis, uveitis)
- Bleeding inside the eye (vitreous haemorrhage)
- Eye discomfort
- Itching (eye pruritus)
- Tearing of the retina (the back of the eye that detects light)
- Red eye (ocular/conjunctival hyperaemia)
- A feeling of having something in the eye
- Blurred vision
- Decreased sharpness of vision (visual acuity reduced)
- Pain during the procedure (procedural pain)
- Detachment of the retina
- Increased tear production (increased lacrimation)
- Scratched cornea, damage to the clear layer of the eyeball that covers the iris (corneal abrasion)
- Eye irritation

Rare (may affect up to 1 in 1 000 people):

- Temporary decreased sharpness of vision (visual acuity reduced transiently)
- Clouding of the lens due to injury (traumatic cataract)

Not known

- Retinal vasculitis (inflammation of blood vessels in the back of the eye)
- Retinal occlusive vasculitis (blockage of blood vessels in the back of the eye, typically in presence of inflammation)

When some medicines that work in a similar way to Vabysmo are given, there is known to be a risk of blood clots blocking blood vessels (arterial thromboembolic events), which may lead to heart attack or stroke. As small amounts of the medicine enter the blood, there is a theoretical risk of such events following injection of Vabysmo into the eye.

Reporting of side effects

If you get any side effects, talk to your doctor. This includes any possible side effects not listed in this leaflet. You can also report side effects directly via [the national reporting system listed in Appendix V](#). By reporting side effects you can help provide more information on the safety of this medicine.

5. How to store Vabysmo

Your doctor, pharmacist or nurse is responsible for storing this medicine and disposing of any unused product correctly. The following information is intended for healthcare professionals.

Keep this medicine out of the sight and reach of children.

Do not use this medicine after the expiry date which is stated on the carton and label after EXP. The expiry date refers to the last day of that month.

Store in a refrigerator (2 °C – 8 °C).

Do not freeze.

Keep the vial in the outer carton in order to protect from light.

Prior to use, the unopened vial may be kept at room temperature, 20 °C to 25 °C, for up to 24 hours.

6. Contents of the pack and other information

What Vabysmo contains

- The active substance is faricimab. One mL solution for injection contains 120 mg faricimab. Each vial contains 28.8 mg faricimab in 0.24 mL solution. This provides a usable amount to deliver a single dose of 0.05 mL solution containing 6 mg of faricimab.
- The other ingredients are: L-histidine, acetic acid 30% (E 260), L-methionine, sodium chloride, sucrose, polysorbate 20 (E 432), water for injections (see Section 2 “Vabysmo contains sodium and polysorbate”).

What Vabysmo looks like and contents of the pack

Vabysmo is a clear to opalescent, colourless to brownish-yellow solution.

Pack size of one glass vial and one sterile blunt transfer filter needle (18-gauge x 1½ inch, 1.2 mm x 40 mm, 5 µm) for single-use only.

Marketing Authorisation Holder

Roche Registration GmbH
Emil-Barell-Strasse 1
79639 Grenzach-Wyhlen
Germany

Manufacturer

Roche Pharma AG
Emil-Barell-Strasse 1
79639 Grenzach-Wyhlen
Germany

For any information about this medicine, please contact the local representative of the Marketing Authorisation Holder:

België/Belgique/Belgien

N.V. Roche S.A.

Tél/Tel: +32 (0) 2 525 82 11

България

Рош България ЕООД

Тел: +359 2 474 5444

Česká republika

Roche s. r. o.

Tel: +420 - 2 20382111

Danmark

Roche Pharmaceuticals A/S

Tlf: +45 - 36 39 99 99

Deutschland

Roche Pharma AG

Tel: +49 (0) 7624 140

Eesti

Roche Eesti OÜ

Tel: + 372 - 6 177 380

Ελλάδα

Roche (Hellas) A.E.

Τηλ: +30 210 61 66 100

España

Roche Farma S.A.

Tel: +34 - 91 324 81 00

France

Roche

Tél: +33 (0)1 47 61 40 00

Hrvatska

Roche d.o.o.

Tel: + 385 1 47 22 333

Ireland

Roche Products (Ireland) Ltd.

Tel: +353 (0) 1 469 0700

Ísland

Roche Pharmaceuticals A/S

c/o Icepharma hf

Sími: +354 540 8000

Italia

Roche S.p.A.

Tel: +39 - 039 2471

Κύπρος

Roche (Hellas) A.E.

Τηλ: +30 210 61 66 100

Lietuva

UAB "Roche Lietuva"

Tel: +370 5 2546799

Luxembourg/Luxemburg

(Voir/siehe Belgique/Belgien)

Magyarország

Roche (Magyarország) Kft.

Tel: +36 - 1 279 4500

Malta

(See Ireland)

Nederland

Roche Nederland B.V.

Tel: +31 (0) 348 438050

Norge

Roche Norge AS

Tlf: +47 - 22 78 90 00

Österreich

Roche Austria GmbH

Tel: +43 (0) 1 27739

Polska

Roche Polska Sp.z o.o.

Tel: +48 - 22 345 18 88.

Portugal

Roche Farmacêutica Química, Lda

Tel: +351 - 21 425 70 00

România

Roche România S.R.L.

Tel: +40 21 206 47 01

Slovenija

Roche farmacevtska družba d.o.o.

Tel: +386 - 1 360 26 00

Slovenská republika

Roche Slovensko, s.r.o.

Tel: +421 - 2 52638201

Suomi/Finland

Roche Oy

Puh/Tel: +358 (0) 10 554 500

Sverige

Roche AB

Tel: +46 (0) 8 726 1200

Latvija
Roche Latvija SIA
Tel: +371 - 6 7039831

This leaflet was last revised in

Detailed information on this medicine is available on the European Medicines Agency web site:
<https://www.ema.europa.eu/en>.

<----->

The following information is intended for healthcare professionals only:

Instructions for use of vial:

Before you start:



Read all the instructions carefully before using Vabysmo.



The Vabysmo kit includes a glass vial and transfer filter needle. The glass vial is for a single dose only. The filter needle is for single use only.



Vabysmo should be stored refrigerated at temperatures between 2 °C to 8 °C.

Do not freeze.

Do not shake.



Allow Vabysmo to reach room temperature, 20 °C to 25 °C before proceeding with the administration. Keep the vial in the original carton to **protect from light**.

The Vabysmo vial may be kept at room temperature for up to **24 hours**.



The Vabysmo vial should be inspected visually prior to administration. Vabysmo is a clear to opalescent and colorless to brownish-yellow liquid solution.

Do not use if particulates, cloudiness, or discoloration are visible.

Do not use if the packaging, vial and/or transfer filter needle are expired, damaged, or have been tampered with (see **Figure A**).

Use aseptic technique to carry out the preparation of the intravitreal injection.



Figure A

Gather supplies

- 1 Gather the following supplies:
 - One Vabysmo vial (included)
 - One sterile 5-micron blunt transfer filter needle 18-gauge x 1½ inch, 1.2 mm x 40 mm (included)
 - One sterile 1 mL Luer lock syringe with a 0.05 mL dose mark (**not included**)
 - One sterile injection needle 30-gauge x ½ inch (**not included**)

Note that a 30-gauge injection needle is recommended to avoid increased injection forces that could be experienced with smaller diameter needles.

- Alcohol swab (**not included**).

- 2 To ensure all liquid settles at the bottom of the vial, place the vial upright on a flat surface (for about 1 minute) after removal from packaging (see **Figure B**). Gently tap the vial with your finger (see **Figure C**), as liquid may stick to the top of the vial.

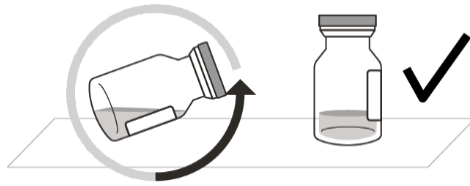

Figure B



Figure C

- 3 Remove the flip-off cap from the vial (see **Figure D**) and wipe the vial septum with an alcohol swab (see **Figure E**).



Figure D

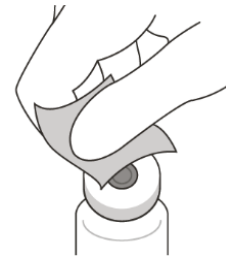

Figure E

Transfer medicinal product from vial to syringe

- 4 Aseptically and firmly attach the included 18-gauge x 1½ inch transfer filter needle onto a 1 mL Luer lock syringe (see **Figure F**).

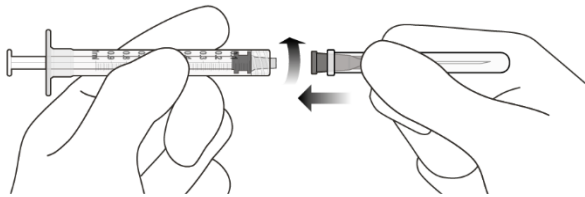

Figure F

- 5 Using aseptic technique, push the transfer filter needle into the center of the vial septum (see **Figure G**), push it all the way in, then tilt the vial slightly so that the needle touches the bottom edge of the vial (see **Figure H**).

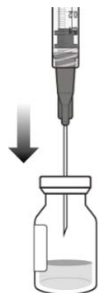

Figure G

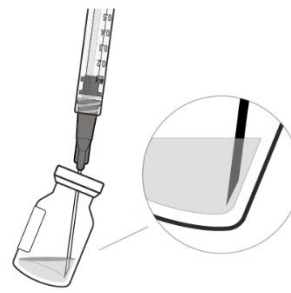

Figure H

- 6 Hold the vial slightly inclined and **slowly** withdraw all the liquid from the vial (see **Figure I**). Keep the bevel of the transfer filter needle submerged in the liquid, to avoid introduction of air.

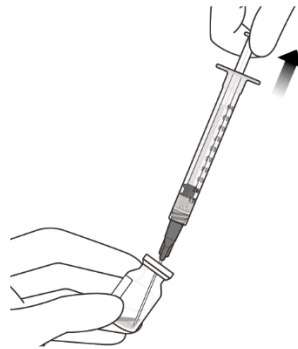

Figure I

Attach injection needle

- 7 Ensure that the plunger rod is drawn sufficiently back when emptying the vial, in order to completely empty the transfer filter needle (see **Figure I**).
- 8 Disconnect the transfer filter needle from the syringe and dispose of it in accordance with local regulations.

Do not use the transfer filter needle for the intravitreal injection.

- 9 Aseptically and firmly attach a 30-gauge x ½ inch injection needle onto the Luer lock syringe (see **Figure J**).

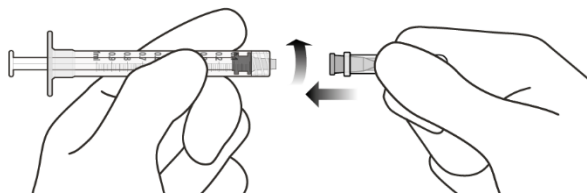

Figure J

Dislodge air bubbles and adjust medicinal product dose

- 10 Carefully remove the plastic needle shield from the needle by pulling it straight off.
- 11 To check for air bubbles, hold the syringe with the needle pointing up. If there are any air bubbles, gently tap the syringe with your finger until the bubbles rise to the top (see **Figure K**).

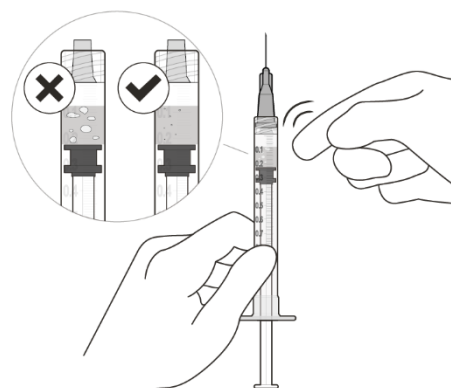

Figure K

- 12 Carefully expel the air from the syringe and needle, and **slowly** depress the plunger to align the rubber stopper tip to the 0.05 mL dose mark. The syringe is ready for the injection (see **Figure L**). Ensure that the injection is given **immediately** after preparation of the dose.

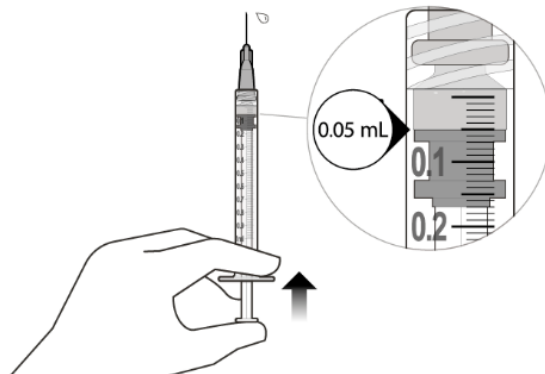

Figure L

- 13 Inject slowly until the rubber stopper reaches the end of the syringe to deliver the volume of 0.05 mL. Confirm delivery of the full dose by checking that the rubber stopper has reached the end of the syringe barrel.

Excess volume should be expelled prior to injection. The injection dose must be set to the 0.05 mL dose mark to avoid overdose.

Any waste material or unused medicinal product should be disposed of in accordance with local regulations.