

ANNEX I
SUMMARY OF PRODUCT CHARACTERISTICS

1. NAME OF THE MEDICINAL PRODUCT

Lonquex 6 mg solution for injection in pre-filled syringe
Lonquex 6 mg/0.6 ml solution for injection

2. QUALITATIVE AND QUANTITATIVE COMPOSITION

Pre-filled syringe

Each pre-filled syringe contains 6 mg of lipegfilgrastim* in 0.6 ml solution.

Vial

Each vial contains 6 mg of lipegfilgrastim* in 0.6 ml solution.

Each ml of solution for injection contains 10 mg of lipegfilgrastim.

The active substance is a covalent conjugate of filgrastim** with methoxy polyethylene glycol (PEG) via a carbohydrate linker.

*This is based on protein content only. The concentration is 20.9 mg/ml (i.e. 12.6 mg per pre-filled syringe or vial) if the PEG moiety and the carbohydrate linker are included.

**Filgrastim (recombinant methionyl human granulocyte-colony stimulating factor [G-CSF]) is produced in *Escherichia coli* cells by recombinant DNA technology.

The potency of this medicinal product should not be compared to the potency of another pegylated or non-pegylated protein of the same therapeutic class. For more information, see section 5.1.

Excipients with known effect

Each pre-filled syringe or vial contains 30 mg sorbitol.

For the full list of excipients, see section 6.1.

3. PHARMACEUTICAL FORM

Solution for injection (injection)

Clear, colourless solution

4. CLINICAL PARTICULARS

4.1 Therapeutic indications

Lonquex is indicated in adults and in children 2 years of age and older for reduction in the duration of neutropenia and the incidence of febrile neutropenia in patients treated with cytotoxic chemotherapy for malignancy (with the exception of chronic myeloid leukaemia and myelodysplastic syndromes).

4.2 Posology and method of administration

Lonquex treatment should be initiated and supervised by physicians experienced in oncology or haematology.

Posology

Adults

The recommended dose is 6 mg (0.6 ml solution in a single pre-filled syringe or vial) of Lonquex for each chemotherapy cycle, given approximately 24 hours after cytotoxic chemotherapy.

Children 2 years of age and older

The recommended dose of Lonquex for paediatric patients is based on body weight according to the table below:

Table 1: Recommended dose in children 2 years of age and older

<u>Body weight (kg)</u>	<u>Dose (for each chemotherapy cycle, given approximately 24 hours after cytotoxic chemotherapy)</u>
< 10	0.6 mg (0.06 ml)
≥ 10 to < 20	1.5 mg (0.15 ml)
≥ 20 to < 30	2.5 mg (0.25 ml)
≥ 30 to < 45	4.0 mg (0.40 ml)
≥ 45	6.0 mg (0.60 ml)

For children weighing 45 kg or more Lonquex can be used as vial or pre-filled syringe presentation.

Special populations

Elderly patients

In clinical studies with a limited number of elderly patients, there was no relevant age-related difference with regard to the efficacy or safety profiles of lipegfilgrastim. Therefore, no adjustment of the dose is necessary for elderly patients.

Renal impairment

Currently available data are described in section 5.2, but no recommendation on a posology can be made.

Hepatic impairment

Currently available data are described in section 5.2, but no recommendation on a posology can be made.

Paediatric patients (children less than 2 years)

The safety and efficacy of Lonquex in children below 2 years of age have not been established. No data are available.

Method of administration

The solution is to be injected subcutaneously (SC). The injection should be given into the abdomen, upper arm or thigh.

Pre-filled syringe

Self-administration of Lonquex should only be performed by patients who are well motivated, adequately trained and have access to expert advice. The first injection should be performed under direct medical supervision.

For instructions on handling of the medicinal product before administration, see section 6.6.

4.3 Contraindications

Hypersensitivity to the active substance or to any of the excipients listed in section 6.1

4.4 Special warnings and precautions for use

Traceability

In order to improve the traceability of biological medicinal products, the trade name and batch number of the administered medicinal product should be clearly recorded in the patient file.

General

The safety and efficacy of Lonquex have not been investigated in patients receiving high dose chemotherapy. Lonquex should not be used to increase the dose of cytotoxic chemotherapy beyond established dose regimens.

Allergic reactions and immunogenicity

Patients who are hypersensitive to G-CSF or derivatives are also at risk of hypersensitivity reactions to lipegfilgrastim due to possible cross-reactivity. No lipegfilgrastim therapy should be commenced in these patients because of the risk of cross-reaction.

Most biological medicinal products elicit some level of anti-drug antibody response. This antibody response can, in some cases, lead to undesirable effects or loss of efficacy. If a patient fails to respond to treatment, the patient should undergo further evaluation.

If a serious allergic reaction occurs, appropriate therapy with close patient follow-up over several days should be administered.

Haematopoietic system

Treatment with lipegfilgrastim does not preclude thrombocytopenia and anaemia caused by myelosuppressive chemotherapy. Lipegfilgrastim may also cause reversible thrombocytopenia (see section 4.8). Regular monitoring of the platelet count and haematocrit is recommended. Special care should be taken when administering single or combination chemotherapeutic medicinal products that are known to cause severe thrombocytopenia.

Leukocytosis may occur (see section 4.8). No adverse events directly attributable to leukocytosis have been reported. Elevation in white blood cells (WBC) is consistent with the pharmacodynamic effects of lipegfilgrastim. A WBC count should be performed at regular intervals during therapy owing to the clinical effects of lipegfilgrastim and the potential for leukocytosis. If WBC counts exceed $50 \times 10^9/l$ after the expected nadir, lipegfilgrastim should be discontinued immediately.

Increased haematopoietic activity of the bone marrow in response to growth factor therapy has been associated with transient positive bone-imaging findings. This should be considered when interpreting bone-imaging results.

Patients with myeloid leukaemia or myelodysplastic syndromes

Granulocyte-colony stimulating factor can promote growth of myeloid cells and some non-myeloid cells *in vitro*.

The safety and efficacy of Lonquex have not been investigated in patients with chronic myeloid leukaemia, myelodysplastic syndromes or secondary acute myeloid leukaemia; it should therefore not be used in such patients. Particular care should be taken to distinguish the diagnosis of blast transformation of chronic myeloid leukaemia from acute myeloid leukaemia.

Myelodysplastic syndrome and acute myeloid leukaemia in breast and lung cancer patients

In an observational post-marketing study, myelodysplastic syndrome (MDS) and acute myeloid leukaemia (AML) were associated with the use of pegfilgrastim, an alternative G-CSF, in combination with chemotherapy and/or radiotherapy in breast and lung cancer patients. A similar association is not known between lipegfilgrastim and MDS/AML. Nevertheless, patients with breast cancer and patients with lung cancer should be monitored for signs and symptoms of MDS/AML.

Splenic adverse reactions

Generally asymptomatic cases of splenomegaly have been reported after administration of lipegfilgrastim (see section 4.8) and infrequent cases of splenic rupture, including fatal cases, have been reported after administration of G-CSF or derivatives (see section 4.8). Spleen size should therefore be carefully monitored (e.g. clinical examination, ultrasound). A diagnosis of splenic rupture should be considered in patients reporting left upper abdominal pain or shoulder tip pain.

Pulmonary adverse reactions

Pulmonary adverse reactions, in particular interstitial pneumonia, have been reported after administration of lipegfilgrastim (see section 4.8). Patients with a recent history of pulmonary infiltrates or pneumonia may be at higher risk.

The onset of pulmonary symptoms such as cough, fever and dyspnoea in association with radiological signs of pulmonary infiltrates and deterioration in pulmonary function together with an increased neutrophil count may be preliminary signs of Acute Respiratory Distress Syndrome (ARDS) (see section 4.8). In such circumstances Lonquex should be discontinued at the discretion of the physician and appropriate treatment given.

Vascular adverse reactions

Capillary leak syndrome has been reported after administration of G-CSF or derivatives and is characterised by hypotension, hypoalbuminaemia, oedema and haemoconcentration. Patients who develop symptoms of capillary leak syndrome should be closely monitored and receive standard symptomatic treatment, which may include a need for intensive care (see section 4.8).

Aortitis has been reported after G-CSF administration in healthy subjects and in cancer patients. The symptoms experienced included fever, abdominal pain, malaise, back pain and increased inflammatory markers (e.g. C-reactive protein and white blood cell count). In most cases aortitis was diagnosed by CT scan and generally resolved after withdrawal of G-CSF. See also section 4.8.

Patients with sickle cell anaemia

Sickle cell crisis has been associated with the use of G-CSF or derivatives in patients with sickle cell anaemia (see section 4.8). Physicians should therefore exercise caution when administering Lonquex in patients with sickle cell anaemia, monitor appropriate clinical parameters and laboratory results and be attentive to the possible association of lipegfilgrastim with splenic enlargement and vaso-occlusive crisis.

Hypokalaemia

Hypokalaemia may occur (see section 4.8). For patients with increased risk on hypokalaemia due to underlying disease or co-medications, it is recommended to monitor the serum potassium level carefully and to substitute potassium if necessary.

Glomerulonephritis

Glomerulonephritis has been reported in patients receiving filgrastim, lenograstim or pegfilgrastim. Generally, events of glomerulonephritis resolved after dose reduction or withdrawal of filgrastim, lenograstim or pegfilgrastim. Urinalysis monitoring is recommended (see section 4.8).

Excipients

This medicinal product contains sorbitol. The additive effect of concomitantly administered products containing sorbitol (or fructose) and dietary intake of sorbitol (or fructose) should be taken into account.

This medicinal product contains less than 1 mmol sodium (23 mg) per pre-filled syringe or vial, i.e. essentially 'sodium-free'.

4.5 Interaction with other medicinal products and other forms of interaction

Due to the potential sensitivity of rapidly dividing myeloid cells to cytotoxic chemotherapy, Lonquex should be administered approximately 24 hours after administration of cytotoxic chemotherapy. Concomitant use of lipegfilgrastim with any chemotherapeutic medicinal product has not been evaluated in patients. In animal models, concomitant administration of G-CSF and 5-fluorouracil (5-FU) or other antimetabolites has been shown to potentiate myelosuppression.

The safety and efficacy of Lonquex have not been evaluated in patients receiving chemotherapy associated with delayed myelosuppression, e.g. nitrosoureas.

The potential for interaction with lithium, which also promotes the release of neutrophils, has not been specifically investigated. There is no evidence that such an interaction would be harmful.

4.6 Fertility, pregnancy and lactation

Pregnancy

There are very limited data (less than 300 pregnancy outcomes) on the use of lipegfilgrastim in pregnant women. Animal studies have shown reproductive toxicity (see section 5.3). As a precautionary measure, it is preferable to avoid the use of Lonquex during pregnancy.

Breast-feeding

It is unknown whether lipegfilgrastim/metabolites are excreted in human milk. A risk to the breast-fed child cannot be excluded. Breast-feeding should be discontinued during treatment with Lonquex.

Fertility

No data are available. Animal studies with G-CSF and derivatives do not indicate harmful effects with respect to fertility (see section 5.3).

4.7 Effects on ability to drive and use machines

Lonquex has no or negligible influence on the ability to drive and use machines.

4.8 Undesirable effects

Summary of the safety profile

The most frequent undesirable effects are musculoskeletal pain and nausea.

Capillary leak syndrome, which can be life-threatening if treatment is delayed, has been reported mostly in cancer patients undergoing chemotherapy after administration of G-CSF or derivatives (see section 4.4 and section 4.8).

Tabulated list of adverse reactions

The safety of lipegfilgrastim has been evaluated based on results from clinical studies including 506 patients and 76 healthy volunteers treated at least once with lipegfilgrastim.

The adverse reactions listed below in table 2 are classified according to system organ class. Frequency groupings are defined according to the following convention: very common ($\geq 1/10$), common ($\geq 1/100$ to $< 1/10$), uncommon ($\geq 1/1\ 000$ to $< 1/100$), rare ($\geq 1/10\ 000$ to $< 1/1\ 000$), very rare ($< 1/10\ 000$), not known (cannot be estimated from the available data).

Within each frequency grouping, adverse reactions are presented in order of decreasing seriousness.

Table 2: Adverse reactions

<u>System organ class</u>	<u>Frequency</u>	<u>Adverse reaction</u>
<i>Blood and lymphatic system disorders</i>	Common	Thrombocytopenia*
	Uncommon	Leukocytosis*, Splenomegaly*
<i>Immune system disorders</i>	Uncommon	Hypersensitivity reactions*
<i>Metabolism and nutrition disorders</i>	Common	Hypokalaemia*
<i>Nervous system disorders</i>	Common	Headache
<i>Vascular disorders</i>	Not known	Capillary leak syndrome*, Aortitis*
<i>Respiratory, thoracic and mediastinal disorders</i>	Common	Haemoptysis
	Uncommon	Pulmonary adverse reactions*, Pulmonary Haemorrhage
<i>Gastrointestinal disorders</i>	Very common	Nausea*
<i>Skin and subcutaneous tissue disorders</i>	Common	Skin reactions*
	Uncommon	Injection site reactions*
<i>Musculoskeletal and connective tissue disorders</i>	Very common	Musculoskeletal pains*
<i>General disorders and administration site conditions</i>	Common	Chest pain
<i>Investigations</i>	Uncommon	Blood alkaline phosphatase increased*, Blood lactate dehydrogenase increased*

*See section "Description of selected adverse reactions" below

Description of selected adverse reactions

Thrombocytopenia and leukocytosis have been reported (see section 4.4).

Splenomegaly, generally asymptomatic, has been reported (see section 4.4).

Hypersensitivity reactions such as allergic skin reactions, urticaria, angioedema and serious allergic reactions may occur.

Hypokalaemia has been reported (see section 4.4).

Pulmonary adverse reactions, in particular interstitial pneumonia, have been reported (see section 4.4). These pulmonary adverse reactions may also include pulmonary oedema, pulmonary infiltrates, pulmonary fibrosis, respiratory failure or ARDS (see section 4.4).

Nausea was very commonly observed in patients receiving chemotherapy.

Skin reactions such as erythema and rash may occur.

Injection site reactions such as injection site induration and injection site pain may occur.

The most frequent adverse reactions include musculoskeletal pains such as bone pain and myalgia. Musculoskeletal pain is generally of mild to moderate severity, transient and can be controlled in most patients with standard analgesics. However cases of severe musculoskeletal pain (mainly bone pain and back pain) have been reported, including cases that led to hospitalisation.

Reversible, mild to moderate elevations in alkaline phosphatase and lactate dehydrogenase may occur, with no associated clinical effects. Elevations in alkaline phosphatase and lactate dehydrogenase most likely originate from the increase in neutrophils.

Certain adverse reactions have not yet been observed with lipegfilgrastim, but are generally accepted as being attributable to G-CSF and derivatives:

Blood and lymphatic system disorders

- Splenic rupture including some fatal cases (see section 4.4)
- Sickle cell crisis in patients with sickle cell anaemia (see section 4.4)

Vascular disorders

- Capillary leak syndrome
Cases of capillary leak syndrome have been reported in post marketing experience after administration of G-CSF or derivatives. These have generally occurred in patients suffering from advanced malignant diseases, having sepsis, taking multiple chemotherapy medicinal products or undergoing apheresis (see section 4.4).
- Aortitis (see section 4.4)

Skin and subcutaneous tissue disorders

- Acute febrile neutrophilic dermatosis (Sweet's syndrome)
- Cutaneous vasculitis

Renal and urinary disorders

- Glomerulonephritis (see section 4.4)

Paediatric population

The safety assessment in paediatric patients is limited to the clinical study data from the following studies:

- a phase I study with 21 paediatric patients aged 2 to 16 years with Ewing family of tumours or rhabdomyosarcoma receiving lipegfilgrastim after a single cycle of chemotherapy (see also section 5.1)
- a phase II study with 21 paediatric patients aged 2 to 18 years with Ewing family of tumours or rhabdomyosarcoma receiving one dose of lipegfilgrastim per chemotherapy cycle, for 4 consecutive cycles (see also section 5.1).

Overall, the safety profile in paediatric patients appeared similar to that observed in adult clinical studies. Some blood and lymphatic system disorders (anaemia, lymphopenia, thrombocytopenia) and gastrointestinal disorders (vomiting) were observed with a higher frequency in paediatric patients than those in adult clinical studies (see also section 5.1).

Reporting of suspected adverse reactions

Reporting suspected adverse reactions after authorisation of the medicinal product is important. It allows continued monitoring of the benefit/risk balance of the medicinal product. Healthcare professionals are asked to report any suspected adverse reactions via the national reporting system listed in Appendix V.

4.9 Overdose

There is no experience with overdose of lipegfilgrastim. In the case of overdose, WBC and platelet count should be performed regularly and spleen size should be carefully monitored (e.g. clinical examination, ultrasound).

5. PHARMACOLOGICAL PROPERTIES

5.1 Pharmacodynamic properties

Pharmacotherapeutic group: Immunostimulants, colony stimulating factors, ATC code: L03AA14

Mechanism of action

Lipegfilgrastim is a covalent conjugate of filgrastim with a single methoxy polyethylene glycol (PEG) molecule via a carbohydrate linker consisting of glycine, *N*-acetylneuraminic acid and *N*-acetylgalactosamine. The average molecular mass is approximately 39 kDa of which the protein moiety constitutes approximately 48 %. Human G-CSF is a glycoprotein that regulates the production and release of functional neutrophils from the bone marrow. Filgrastim is an un-glycosylated recombinant methionyl human G-CSF. Lipegfilgrastim is a sustained duration form of filgrastim due to decreased renal clearance. Lipegfilgrastim binds to human the G-CSF receptor like filgrastim and pegfilgrastim.

Pharmacodynamic effects

Lipegfilgrastim and filgrastim induced a marked increase in peripheral blood neutrophil counts within 24 hours, with minor increases in monocytes and/or lymphocytes. These results suggest that the G-CSF moiety of lipegfilgrastim confers the expected activity of this growth factor: stimulation of proliferation of haematopoietic progenitor cells, differentiation into mature cells and release into the peripheral blood. This effect includes not only the neutrophil lineage but extends to other single lineage and multilineage progenitors and pluripotent haematopoietic stem cells. G-CSF also increases the antibacterial activities of neutrophils including the phagocytosis.

Clinical efficacy and safety

Once-per-cycle dosing of lipegfilgrastim was investigated in two pivotal randomised, double-blind clinical studies in patients undergoing myelosuppressive chemotherapy.

The first pivotal (phase III) clinical study XM22-03 was an active-controlled study in 202 patients with stage II-IV breast cancer receiving up to 4 cycles of chemotherapy consisting of doxorubicin and docetaxel. Patients were randomised 1:1 to receive 6 mg lipegfilgrastim or 6 mg pegfilgrastim. The study showed non-inferiority of 6 mg lipegfilgrastim to 6 mg pegfilgrastim for the primary endpoint, duration of severe neutropenia (DSN) in the first cycle of chemotherapy (see table 3).

Table 3: DSN, severe neutropenia (SN) and febrile neutropenia (FN) in cycle 1 of study XM22-03 (ITT)

	Pegfilgrastim 6 mg (n = 101)	Lipegfilgrastim 6 mg (n = 101)
<u>DSN</u>		
Mean ± SD (d)	0.9 ± 0.9	0.7 ± 1.0
Δ LS mean	-0.186	
95 % CI	-0.461 to 0.089	
<u>SN</u>		
Incidence (%)	51.5	43.6
<u>FN</u>		
Incidence (%)	3.0	1.0
ITT = Intent-to-treat population (all randomised patients) SD = standard deviation d = days CI = confidence interval Δ LS mean (least square mean difference lipegfilgrastim – pegfilgrastim) and CI out of multivariate Poisson regression analysis		

The second pivotal (phase III) clinical study XM22-04 was a placebo-controlled study in 375 patients with non-small cell lung cancer receiving up to 4 cycles of chemotherapy consisting of cisplatin and etoposide. Patients were randomised 2:1 to receive either 6 mg lipegfilgrastim or placebo. The results of the study are presented in table 4. When the main study was finalised, the incidence of death was 7.2 % (placebo) and 12.5 % (6 mg lipegfilgrastim) although after the 360-day follow-up period the overall incidence of death was similar between placebo and lipegfilgrastim (44.8 % and 44.0 %; safety population).

Table 4: DSN, SN and FN in cycle 1 of study XM22-04 (ITT)

	Placebo (n = 125)	Lipegfilgrastim 6 mg (n = 250)
<u>FN</u>		
Incidence (%)	5.6	2.4
95 % CI	0.121 to 1.260	
p-value	0.1151	
<u>DSN</u>		
Mean ± SD (d)	2.3 ± 2.5	0.6 ± 1.1
Δ LS mean	-1.661	
95 % CI	-2.089 to -1.232	
p-value	< 0.0001	
<u>SN</u>		
Incidence (%)	59.2	32.1
Odds ratio	0.325	
95 % CI	0.206 to 0.512	
p-value	< 0.0001	
Δ LS mean (least square mean difference lipegfilgrastim – placebo), CI and p-value out of multivariate Poisson regression analysis Odds ratio (lipegfilgrastim / placebo), CI and p-value out of multivariate logistic regression analysis		

A post-authorisation safety study XM22-ONC-40041 was conducted to collect data of disease progression and mortality in patients with advanced squamous or non-squamous cell lung cancer receiving lipegfilgrastim in addition to the platinum-based chemotherapy. Increased risk of disease progression or death was not observed with lipegfilgrastim.

Immunogenicity

An analysis of anti-drug antibodies of 579 patients and healthy volunteers treated with lipegfilgrastim, 188 patients and healthy volunteers treated with pegfilgrastim and 121 patients treated with placebo

was performed. Drug-specific antibodies emerging after start of treatment were detected in 0.86 % of the subjects receiving lipegfilgrastim, in 1.06 % of the subjects receiving pegfilgrastim and in 1.65 % of the subjects receiving placebo. No neutralising antibodies against lipegfilgrastim were observed.

Paediatric population

Two clinical studies (XM22-07 and XM22-08) were conducted in paediatric populations using lipegfilgrastim for the treatment of chemotherapy-induced neutropenia and the prevention of chemotherapy-induced febrile neutropenia. In both studies, lipegfilgrastim was supplied in glass vials containing 10 mg of lipegfilgrastim in a 1 ml solution for subcutaneous injection.

In the phase I study (XM22-07), 21 children aged between 2 and 16 years with Ewing family of tumours or rhabdomyosarcoma received lipegfilgrastim as a single subcutaneous dose of 100 µg/kg (up to a maximum of 6 mg, which is the fixed dose for adults) 24 hours after the end of the last chemotherapy treatment in week 1 of the regimen. The chemotherapy regimens consisted of: vincristine, ifosfamide, doxorubicin and etoposide (VIDE); vincristine, actinomycin D and cyclophosphamide (VAC); or ifosfamide, vincristine, and actinomycin D (IVA). The incidence of FN varied according to age (from 14.3 % to 71.4 %), with the highest frequency in the oldest age group. The use of three different chemotherapy regimens, with varying myelosuppressive effects and age distributions, complicated the comparison of efficacy across age groups.

In the phase II study (XM22-08), 42 children aged between 2 and < 18 years with Ewing family of tumours or rhabdomyosarcoma received for 4 consecutive chemotherapy cycles in a randomised 1:1 ratio either lipegfilgrastim at a dose of 100 µg/kg (up to a maximum of 6 mg, 1 dose per cycle) or filgrastim at a dose of 5 µg/kg (once daily for at least 5 consecutive days per cycle [maximum of 14 days]). The chemotherapy regimens consisted of: VIDE; VAC; IVA; vincristine, doxorubicin, and cyclophosphamide alternating with ifosfamide and etoposide (VDC/IE); or ifosfamide, vincristine, actinomycin D and doxorubicin (IVADo). The primary endpoint was the duration of severe neutropenia (DSN) in cycle 1. DSN (mean [standard deviation]) in cycle 1 was 2.7 (2.25) days in the lipegfilgrastim group and 2.5 (2.09) days in the filgrastim group (Per Protocol [PP] Analysis set). The overall incidence of febrile neutropenia was 35 % in the lipegfilgrastim group and 42% in the filgrastim group (PP Analysis Set). The study was not powered for formal hypothesis testing. Therefore, results from this study should be interpreted with caution.

5.2 Pharmacokinetic properties

General

Healthy volunteers

In 3 studies (XM22-01, XM22-05, XM22-06) in healthy volunteers, the maximum blood concentration was reached after a median of 30 to 36 hours and the average terminal half-life ranged from approximately 32 to 62 hours after a single subcutaneous injection of 6 mg lipegfilgrastim.

After subcutaneous injection of 6 mg lipegfilgrastim at three different sites (upper arm, abdomen and thigh) in healthy volunteers, the bioavailability (peak concentration and area under the curve [AUC]) was lower after subcutaneous injection in the thigh compared to subcutaneous injection in the abdomen and in the upper arm. In this limited study XM22-06, bioavailability of lipegfilgrastim and observed differences among the injection sites were higher in male subjects compared to female subjects. Nevertheless, pharmacodynamic effects were similar and independent from gender and injection site.

Metabolism

Lipegfilgrastim is metabolised via intra- or extracellular degradation by proteolytic enzymes. Lipegfilgrastim is internalised by neutrophils (non-linear process), then degraded within the cell by endogenous proteolytic enzymes. The linear pathway is likely due to extracellular protein degradation by neutrophil elastase and other plasma proteases.

Drug interactions

In vitro data indicate that lipegfilgrastim has little or no direct or immune system-mediated effects on CYP1A2, CYP2B6, CYP2C8, CYP2C9, CYP2C19, and CYP3A4/5 activity. Therefore, lipegfilgrastim is not likely to affect metabolism via human cytochrome P450 enzymes.

Special populations

Cancer patients

In 2 studies (XM22-02 and XM22-03) in patients with breast cancer receiving chemotherapy consisting of doxorubicin and docetaxel, mean maximum blood concentrations of 227 and 262 ng/ml were reached after median times to maximum concentration (t_{max}) of 44 and 48 hours. The mean terminal half-lives were approximately 29 and 31 hours after a single subcutaneous injection of 6 mg lipegfilgrastim during the first cycle of chemotherapy. After a single subcutaneous injection of 6 mg lipegfilgrastim during the fourth cycle, the maximum blood concentrations were lower than observed in the first cycle (mean values 77 and 111 ng/ml) and were reached after median t_{max} of 8 hours. The mean terminal half-lives in the fourth cycle were approximately 39 and 42 hours.

In a study (XM22-04) in patients with non-small cell lung cancer receiving chemotherapy consisting of cisplatin and etoposide, the mean maximum blood concentration of 317 ng/ml was reached after a median t_{max} of 24 hours and the mean terminal half-life was approximately 28 hours after a single subcutaneous injection of 6 mg lipegfilgrastim during the first cycle of chemotherapy. After a single subcutaneous injection of 6 mg lipegfilgrastim during the fourth cycle, the mean maximum blood concentration of 149 ng/ml was reached after a median t_{max} of 8 hours and the mean terminal half-life was approximately 34 hours.

Lipegfilgrastim appears to be mainly eliminated by neutrophil-mediated clearance, which becomes saturated at higher doses. Consistent with a self-regulating clearance mechanism, the serum concentration of lipegfilgrastim declines slowly during the chemotherapy-induced transient neutrophil nadir and rapidly at the following onset of neutrophil recovery (see figure 1).

Figure 1: Profile of median serum concentration of lipegfilgrastim and median ANC in chemotherapy-treated patients after a single 6 mg injection of lipegfilgrastim

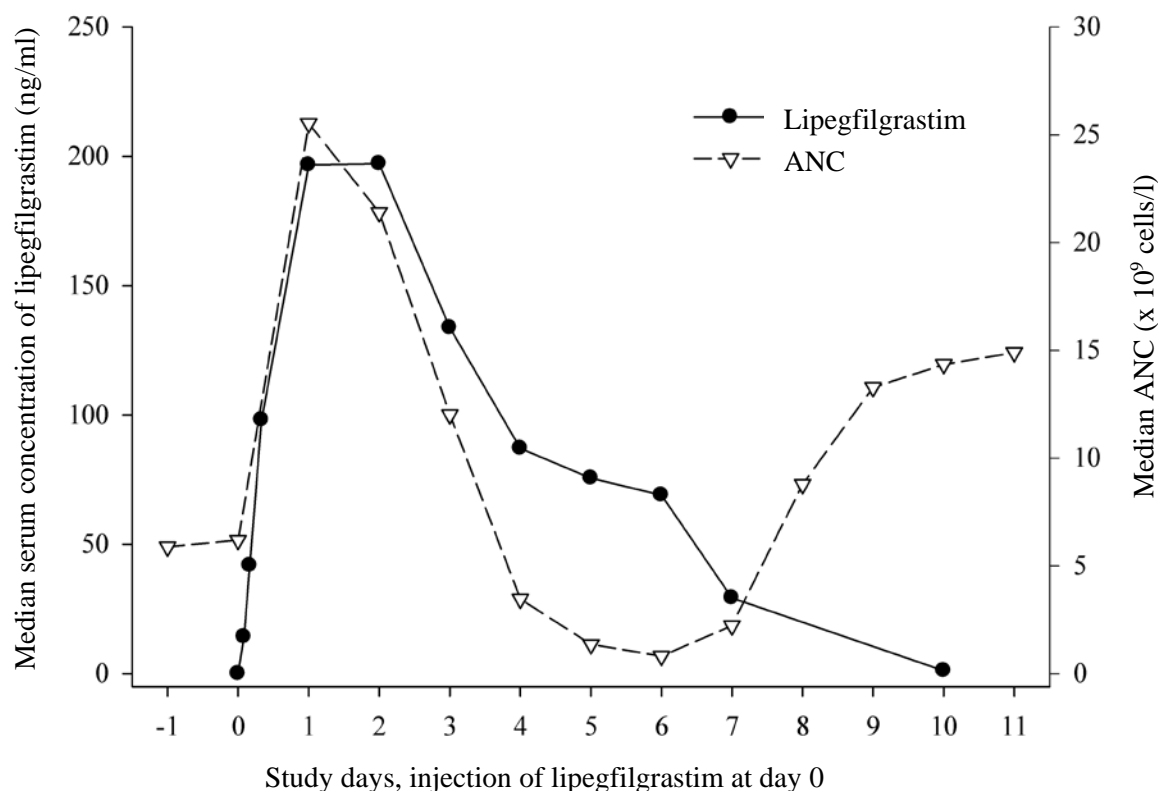

Patients with renal or hepatic impairment

Due to the neutrophil-mediated clearance mechanism, the pharmacokinetics of lipegfilgrastim is not expected to be affected by renal or hepatic impairment.

Elderly patients

Limited patient data indicate that the pharmacokinetics of lipegfilgrastim in elderly patients (65 - 74 years) is similar to that in younger patients. No pharmacokinetic data are available in patients ≥ 75 years.

Paediatric population

In a phase I study (see section 5.1) the geometric mean maximum blood concentrations (C_{max}) were 243 ng/ml in the 2 to < 6-year group, 255 ng/ml in the 6 to < 12-year group and 224 ng/ml in the 12 to < 18-year group after a single subcutaneous injection of 100 $\mu\text{g}/\text{kg}$ (maximum 6 mg) lipegfilgrastim with the first cycle of chemotherapy. The maximum blood concentrations were reached after a median time (t_{max}) of 23.9 hours, 30.0 hours and 95.8 hours, respectively.

Pharmacokinetic and pharmacodynamic (PK-PD) modelling of paediatric data (aged 2 to < 18 years with administered doses of 100 $\mu\text{g}/\text{kg}$), including additional data from the phase II study (see section 5.1) and combined with previous adult PK data, support that comparable lipegfilgrastim serum exposures were achieved in paediatric patients as compared to adult patients, and that PK and PD parameters were comparable across the paediatric weight bands studied and support the dose recommendation by body weight ranges for paediatric patients.

Overweight patients

A trend towards a decrease in lipegfilgrastim exposure was observed with increase in weight. This may result in lowered pharmacodynamic responses in heavy patients (> 95 kg). Consequent decrease in efficacy in these patients cannot be excluded on current data.

5.3 Preclinical safety data

Non-clinical data reveal no special hazard for humans based on conventional studies of safety pharmacology, single and repeated dose toxicity and local tolerance.

In a study of toxicity to reproduction and development in rabbits, an increased incidence of post-implantation loss and abortion has been observed at high doses of lipegfilgrastim, likely owing to an exaggerated pharmacodynamic effect specific for rabbits. There is no evidence that lipegfilgrastim is teratogenic. These findings are consistent with results from G-CSF and derivatives. Published information on G-CSF and derivatives reveal no evidence of adverse effects on fertility and embryo-foetal development in rats or pre-/postnatal effects other than those related to maternal toxicity as well. There is evidence that filgrastim and pegfilgrastim may be transported at low levels over the placenta in rats, although no information is available for lipegfilgrastim. The relevance of these findings for humans is not known.

6. PHARMACEUTICAL PARTICULARS

6.1 List of excipients

Glacial acetic acid
Sodium hydroxide (for pH-adjustment)
Sorbitol (E420)
Polysorbate 20
Water for injections

6.2 Incompatibilities

In the absence of compatibility studies, this medicinal product must not be mixed with other medicinal products.

6.3 Shelf life

3 years

6.4 Special precautions for storage

Store in a refrigerator (2 °C – 8 °C).

Do not freeze.

Keep the pre-filled syringe or vial in the outer carton in order to protect from light.

Lonquex may be removed from the refrigerator and stored below 25 °C for a maximum single period of up to 7 days. Once removed from the refrigerator, the medicinal product must be used within this period or disposed of.

6.5 Nature and contents of container

Pre-filled syringe

Pre-filled syringe (type I glass) with a plunger stopper [poly(ethylene-co-tetrafluoroethylene)-coated bromobutyl rubber] and a fixed injection needle (stainless steel, 29G [0.34 mm] or 27G [0.4 mm] x 0.5 inch [12.7 mm]).

Each pre-filled syringe contains 0.6 ml of solution.

Pack sizes of 1 and 4 pre-filled syringes with safety device (which prevents needle stick injury and re-use) or 1 pre-filled syringe without safety device.

Not all pack sizes may be marketed.

Vial

Type I clear, borosilicate glass vial with a bromobutyl rubber stopper and an aluminium crimp seal with polypropylene flip-off cap.

Each vial contains 0.6 ml of solution.

Pack sizes of 1 or 6 vials.

Not all pack sizes may be marketed.

6.6 Special precautions for disposal and other handling

The solution should be visually inspected before use. Only clear, colourless solutions without particles should be used.

The solution should be allowed to reach a comfortable temperature (15 °C – 25 °C) for injection.

Vigorous shaking should be avoided. Excessive shaking may aggregate lipegfilgrastim, rendering it biologically inactive.

Lonquex does not contain any preservative. In view of the possible risk of microbial contamination, Lonquex syringes or vials are for single use only. Any unused portions of each vial must be discarded properly. Do not save any unused portions for later administrations.

Any unused medicinal product or waste material should be disposed of in accordance with local requirements.

7. MARKETING AUTHORISATION HOLDER

Teva B.V.
Swensweg 5
2031 GA Haarlem
Netherlands

8. MARKETING AUTHORISATION NUMBER(S)

Pre-filled syringe

EU/1/13/856/001
EU/1/13/856/002
EU/1/13/856/003

Vial

EU/1/13/856/004
EU/1/13/856/005

9. DATE OF FIRST AUTHORISATION/RENEWAL OF THE AUTHORISATION

Date of first authorisation: 25 July 2013
Date of latest renewal: 19 April 2023

10. DATE OF REVISION OF THE TEXT

Detailed information on this medicinal product is available on the website of the European Medicines Agency <http://www.ema.europa.eu>.

ANNEX II

- A. MANUFACTURER OF THE BIOLOGICAL ACTIVE
SUBSTANCE AND MANUFACTURER RESPONSIBLE FOR
BATCH RELEASE**
- B. CONDITIONS OR RESTRICTIONS REGARDING SUPPLY
AND USE**
- C. OTHER CONDITIONS AND REQUIREMENTS OF THE
MARKETING AUTHORISATION**
- D. CONDITIONS OR RESTRICTIONS WITH REGARD TO
THE SAFE AND EFFECTIVE USE OF THE MEDICINAL
PRODUCT**

A. MANUFACTURER OF THE BIOLOGICAL ACTIVE SUBSTANCE AND MANUFACTURER RESPONSIBLE FOR BATCH RELEASE

Name and address of the manufacturer of the biological active substance

UAB Teva Baltics
Molėtų pl. 5
08409 Vilnius
Lithuania

Name and address of the manufacturer responsible for batch release

Merckle GmbH,
Graf-Arco-Straße 3
89079 Ulm
Germany

B. CONDITIONS OR RESTRICTIONS REGARDING SUPPLY AND USE

Medicinal product subject to restricted medical prescription (see Annex I: Summary of Product Characteristics, section 4.2).

C. OTHER CONDITIONS AND REQUIREMENTS OF THE MARKETING AUTHORISATION

- **Periodic safety update reports (PSURs)**

The requirements for submission of PSURs for this medicinal product are set out in the list of Union reference dates (EURD list) provided for under Article 107c(7) of Directive 2001/83/EC and any subsequent updates published on the European medicines web-portal.

D. CONDITIONS OR RESTRICTIONS WITH REGARD TO THE SAFE AND EFFECTIVE USE OF THE MEDICINAL PRODUCT

- **Risk management plan (RMP)**

The marketing authorisation holder (MAH) shall perform the required pharmacovigilance activities and interventions detailed in the agreed RMP presented in Module 1.8.2 of the Marketing Authorisation and any agreed subsequent updates of the RMP.

An updated RMP should be submitted:

- At the request of the European Medicines Agency;
- Whenever the risk management system is modified, especially as the result of new information being received that may lead to a significant change to the benefit/risk profile or as the result of an important (pharmacovigilance or risk minimisation) milestone being reached.

ANNEX III
LABELLING AND PACKAGE LEAFLET

A. LABELLING

PARTICULARS TO APPEAR ON THE OUTER PACKAGING

OUTER CARTON – PRE-FILLED SYRINGE

1. NAME OF THE MEDICINAL PRODUCT

Lonquex 6 mg solution for injection in pre-filled syringe
lipegfilgrastim

2. STATEMENT OF ACTIVE SUBSTANCE(S)

Each pre-filled syringe contains 6 mg lipegfilgrastim in 0.6 ml solution. Each ml of solution contains 10 mg lipegfilgrastim.

3. LIST OF EXCIPIENTS

Excipients: Glacial acetic acid, sodium hydroxide, sorbitol (E420), polysorbate 20 and water for injections.

4. PHARMACEUTICAL FORM AND CONTENTS

Solution for injection

1 pre-filled syringe of 0.6 ml solution
1 pre-filled syringe of 0.6 ml solution with safety device
4 pre-filled syringes of 0.6 ml solution with safety device

5. METHOD AND ROUTE(S) OF ADMINISTRATION

For single use only.

Avoid vigorous shaking.

Read the package leaflet before use.

Subcutaneous use

6. SPECIAL WARNING THAT THE MEDICINAL PRODUCT MUST BE STORED OUT OF THE SIGHT AND REACH OF CHILDREN

Keep out of the sight and reach of children.

7. OTHER SPECIAL WARNING(S), IF NECESSARY

8. EXPIRY DATE

EXP

9. SPECIAL STORAGE CONDITIONS

Store in a refrigerator.

Do not freeze.

Keep the pre-filled syringe in the outer carton in order to protect from light.

10. SPECIAL PRECAUTIONS FOR DISPOSAL OF UNUSED MEDICINAL PRODUCTS OR WASTE MATERIALS DERIVED FROM SUCH MEDICINAL PRODUCTS, IF APPROPRIATE

11. NAME AND ADDRESS OF THE MARKETING AUTHORISATION HOLDER

Teva B.V.
Swensweg 5
2031 GA Haarlem
Netherlands

12. MARKETING AUTHORISATION NUMBER(S)

EU/1/13/856/001 1 pre-filled syringe with safety device
EU/1/13/856/002 1 pre-filled syringe
EU/1/13/856/003 4 pre-filled syringes with safety device

13. BATCH NUMBER

Lot

14. GENERAL CLASSIFICATION FOR SUPPLY

15. INSTRUCTIONS ON USE

16. INFORMATION IN BRAILLE

Lonquex 6 mg

17. UNIQUE IDENTIFIER – 2D BARCODE

2D barcode carrying the unique identifier included.

18. UNIQUE IDENTIFIER - HUMAN READABLE DATA

PC

SN
NN

**MINIMUM PARTICULARS TO APPEAR ON SMALL IMMEDIATE PACKAGING UNITS
PRE-FILLED SYRINGE**

1. NAME OF THE MEDICINAL PRODUCT AND ROUTE(S) OF ADMINISTRATION

Lonquex 6 mg injection
lipegfilgrastim

SC

2. METHOD OF ADMINISTRATION

3. EXPIRY DATE

EXP

4. BATCH NUMBER

Lot

5. CONTENTS BY WEIGHT, BY VOLUME OR BY UNIT

0.6 ml

6. OTHER

PARTICULARS TO APPEAR ON THE OUTER PACKAGING

OUTER CARTON – VIAL

1. NAME OF THE MEDICINAL PRODUCT

Lonquex 6 mg/0.6 ml solution for injection
lipegfilgrastim

2. STATEMENT OF ACTIVE SUBSTANCE(S)

Each vial contains 6 mg lipegfilgrastim in 0.6 ml solution. Each ml of solution contains 10 mg lipegfilgrastim.

3. LIST OF EXCIPIENTS

Excipients: Glacial acetic acid, sodium hydroxide, sorbitol (E420), polysorbate 20 and water for injections.

4. PHARMACEUTICAL FORM AND CONTENTS

Solution for injection

6 vials

1 vial

6 mg/0.6 ml

5. METHOD AND ROUTE(S) OF ADMINISTRATION

For single use only.

Avoid vigorous shaking.

Read the package leaflet before use.

Subcutaneous use

6. SPECIAL WARNING THAT THE MEDICINAL PRODUCT MUST BE STORED OUT OF THE SIGHT AND REACH OF CHILDREN

Keep out of the sight and reach of children.

7. OTHER SPECIAL WARNING(S), IF NECESSARY

8. EXPIRY DATE

EXP

9. SPECIAL STORAGE CONDITIONS

Store in a refrigerator.

Do not freeze.

Keep the vial in the outer carton in order to protect from light.

10. SPECIAL PRECAUTIONS FOR DISPOSAL OF UNUSED MEDICINAL PRODUCTS OR WASTE MATERIALS DERIVED FROM SUCH MEDICINAL PRODUCTS, IF APPROPRIATE**11. NAME AND ADDRESS OF THE MARKETING AUTHORISATION HOLDER**

Teva B.V.
Swensweg 5
2031 GA Haarlem
Netherlands

12. MARKETING AUTHORISATION NUMBER(S)

EU/1/13/856/004 6 vials
EU/1/13/856/005 1 vial

13. BATCH NUMBER

Lot

14. GENERAL CLASSIFICATION FOR SUPPLY**15. INSTRUCTIONS ON USE****16. INFORMATION IN BRAILLE**

Justification for not including Braille accepted.

17. UNIQUE IDENTIFIER – 2D BARCODE

2D barcode carrying the unique identifier included.

18. UNIQUE IDENTIFIER - HUMAN READABLE DATA

PC
SN
NN

MINIMUM PARTICULARS TO APPEAR ON SMALL IMMEDIATE PACKAGING UNITS

VIAL

1. NAME OF THE MEDICINAL PRODUCT AND ROUTE(S) OF ADMINISTRATION

Lonquex 6 mg/0.6 ml injection
lipegfilgrastim

SC

2. METHOD OF ADMINISTRATION

3. EXPIRY DATE

EXP

4. BATCH NUMBER

Lot

5. CONTENTS BY WEIGHT, BY VOLUME OR BY UNIT

6 mg/0.6 ml

6. OTHER

B. PACKAGE LEAFLET

Package leaflet: Information for the patient

Lonquex 6 mg solution for injection in pre-filled syringe lipegfilgrastim

Read all of this leaflet carefully before you start using this medicine because it contains important information for you.

- Keep this leaflet. You may need to read it again.
- If you have any further questions, ask your doctor, pharmacist or nurse.
- This medicine has been prescribed for you only. Do not pass it on to others. It may harm them, even if their signs of illness are the same as yours.
- If you get any side effects, talk to your doctor, pharmacist or nurse. This includes any possible side effects not listed in this leaflet. See section 4.

What is in this leaflet

1. What Lonquex is and what it is used for
2. What you need to know before you use Lonquex
3. How to use Lonquex
4. Possible side effects
5. How to store Lonquex
6. Contents of the pack and other information

1. What Lonquex is and what it is used for

What Lonquex is

Lonquex contains the active substance lipegfilgrastim. Lipegfilgrastim is a long-acting modified protein produced by biotechnology in bacteria called *Escherichia coli*. It belongs to a group of proteins called cytokines and is similar to a natural protein (granulocyte-colony stimulating factor [G-CSF]) produced by your own body.

What Lonquex is used for

Lonquex is used in adults and in children aged 2 years and older.

Your doctor has prescribed Lonquex for you or for your child in order to reduce the duration of a condition called neutropenia (low white blood cell count) and the occurrence of febrile neutropenia (low white blood cell count with a fever). These can be caused by the use of cytotoxic chemotherapy (medicines that destroy rapidly-growing cells).

How Lonquex works

Lipegfilgrastim stimulates the bone marrow (the tissue where new blood cells are made) to produce more white blood cells. White blood cells are important as they help your body fight infection. These cells are very sensitive to the effects of chemotherapy which can cause the number of these cells in your body to decrease. If white blood cells fall to a low level, there may not be enough left in the body to fight bacteria and you may have an increased risk of infection.

2. What you need to know before you use Lonquex

Do not use Lonquex

- if you or your child are allergic to lipegfilgrastim or any of the other ingredients of this medicine (listed in section 6).

Warnings and precautions

Talk to your doctor, pharmacist or nurse before using Lonquex:

- if you or your child get left upper abdominal pain or pain at the tip of your shoulder. It could be a consequence of a spleen disorder (see section 4 “Possible side effects”).
- if you or your child have a cough, fever and difficulty breathing. It could be a consequence of a pulmonary disorder (see section 4 “Possible side effects”).
- if you or your child have sickle cell anaemia, which is an inherited disease characterised by sickle-shaped red blood cells.
- if you or your child have previously experienced allergic reactions to other medicines like this one (e.g. filgrastim, lenograstim or pegfilgrastim of the group of G-CSFs). There could be a risk of reacting to Lonquex too.

Your doctor will carry out regular blood tests in order to monitor various blood components and their levels. Your doctor will also check your or your child’s urine regularly as other medicines similar to this one (e.g. other granulocyte colony stimulating factors such as filgrastim, lenograstim or pegfilgrastim) can possibly harm the tiny filters inside your kidneys (glomerulonephritis; see section 4 “Possible side effects”).

Tell your doctor if you or your child are being treated for breast or lung cancer in combination with chemotherapy and/or radiation therapy and experience symptoms such as tiredness, fever, and easy bruising or bleeding. These symptoms could be a consequence of a precancerous blood condition called myelodysplastic syndrome (MDS) or of a blood cancer called acute myeloid leukaemia (AML) which have been associated with another medicine like this one (pegfilgrastim of the group of G-CSFs).

Inflammation of the aorta (the large blood vessel which transports blood from the heart to the body) has been reported rarely with other medicines like this one (e.g. filgrastim, lenograstim or pegfilgrastim of the group of G-CSFs). The symptoms can include fever, abdominal pain, malaise, back pain and increased inflammatory markers. Tell your doctor if you experience these symptoms.

Children and adolescents

Lonquex is not recommended for children younger than 2 years of age.

Other medicines and Lonquex

Tell your doctor or pharmacist if you or your child are using, have recently used or might use any other medicines.

Pregnancy and breast-feeding

Lonquex has not been tested in pregnant women. It is important to tell your doctor if you are pregnant, think you may be pregnant or are planning to have a baby, as the doctor may decide that you should not use this medicine.

It is unknown whether the active substance in this medicine passes into the breast milk. You should therefore interrupt breast-feeding during treatment.

Driving and using machines

Lonquex has no or negligible influence on your ability to drive and use machines.

Lonquex contains sorbitol

This medicine contains 30 mg sorbitol in each pre-filled syringe.

Lonquex contains sodium

This medicine contains less than 1 mmol sodium (23 mg) per pre-filled syringe, that is to say essentially ‘sodium-free’.

3. How to use Lonquex

Always use this medicine exactly as your doctor or pharmacist has told you. Check with your doctor or pharmacist if you are not sure.

What the recommended dose is

The recommended dose is one pre-filled syringe (6 mg lipegfilgrastim) *once per chemotherapy cycle*.

The pre-filled syringe is only suitable for adults or for children weighing 45 kg and more.

Lonquex is also available in a vial presentation for children weighing less than 45 kg. The recommended dose will be based on their body weight and the adequate dose will be given by a doctor or a nurse.

When to use Lonquex

The Lonquex dose will normally be injected approximately 24 hours after the last dose of chemotherapy at the end of each chemotherapy cycle.

How are the injections given?

This medicine is given as an injection using a pre-filled syringe. The injection is given into the tissue just under the skin (subcutaneous injection).

Your doctor may suggest that you learn how to inject yourself with this medicine or how to give the injection to your child. Your doctor or nurse will give you instructions on how to do this. Do not attempt to give Lonquex to yourself or to your child without this training. Information required for using the pre-filled syringe can be found under “Information for injecting yourself or your child”. Proper treatment of your or of your child’s disease, however, requires close and constant co-operation with your doctor.

Information for injecting yourself or your child

This section contains information on how to give yourself or your child an injection of Lonquex under the skin. It is important that you do not try to give yourself or your child the injection unless you have received special training from your doctor or nurse. If you are not sure about giving yourself or your child the injection or you have any questions, please ask your doctor or nurse for help.

How Lonquex is used

You will need to give yourself or your child the injection into the tissue just under the skin. This is known as a subcutaneous injection.

Equipment that you need

To give yourself or your child an injection into the tissue under the skin you will need:

- a pre-filled syringe of Lonquex,
- an alcohol wipe,
- a piece of gauze bandage or a sterile gauze swab,
- a puncture-proof container (plastic container provided by the hospital or pharmacy) so you can dispose of used syringes safely.

What you should do before the injection

1. Take the medicine out of the refrigerator.
2. Open the blister and take the pre-filled syringe out of the blister (see picture 1). Do not pick up the pre-filled syringe by the plunger or needle cover.
3. Check the expiry date on the pre-filled syringe label (EXP). Do not use it if the date has passed the last day of the month shown.
4. Check the appearance of Lonquex. It must be a clear and colourless liquid. If there are particles in it or if it is cloudy, you must not use it.
5. Do not shake Lonquex vigorously as this may affect its activity.
6. For a more comfortable injection:

- let the pre-filled syringe stand for 30 minutes to reach room temperature (not above 25 °C) or
- hold the pre-filled syringe gently in your hand for a few minutes.

Do **not** warm Lonquex in any other way (for example, do not warm it in a microwave or in hot water).

7. Do **not** remove the needle cover from the syringe until you are ready to inject.
8. Find a comfortable, well-lit place. Put everything you need within easy reach (the Lonquex pre-filled syringe, an alcohol wipe, a piece of gauze bandage or a sterile gauze swab and the puncture-proof container).
9. **Wash your hands thoroughly.**

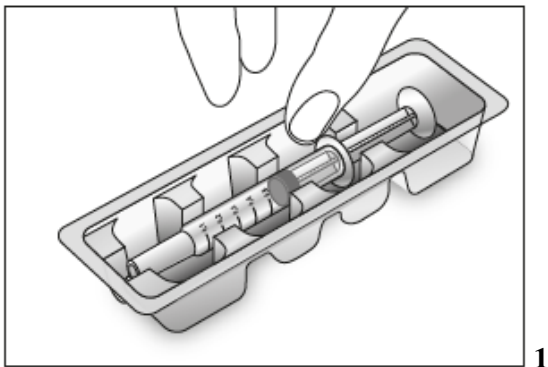

1

Where the injection should be given

The most suitable places for the injection are:

- the top of the thighs,
- the abdomen (see grey areas in picture 2) avoiding the skin directly surrounding the navel.

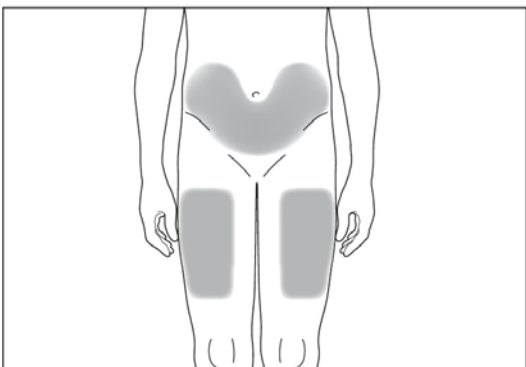

2

If someone else is injecting you or if you are injecting your child, the following places can also be used:

- the back and side of the upper arms (see grey areas in pictures 3 and 4).

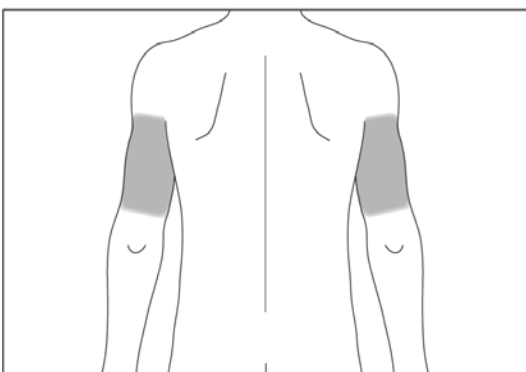

3

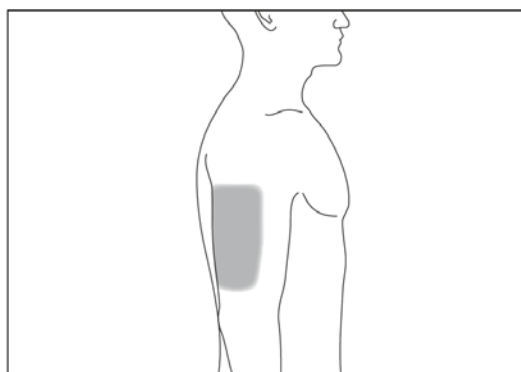

4

How to prepare for the injection

Before you give yourself or your child a Lonquex injection, you must do the following:

1. Disinfect the injection site on the skin by using an alcohol wipe.
2. Hold the syringe and gently remove the cover from the needle without twisting. Pull straight as shown in pictures 5 and 6. Do not touch the needle or push the plunger.

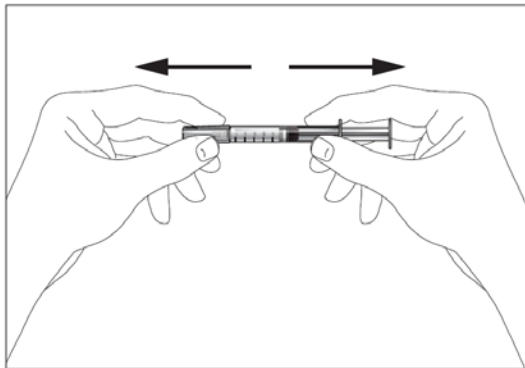

5

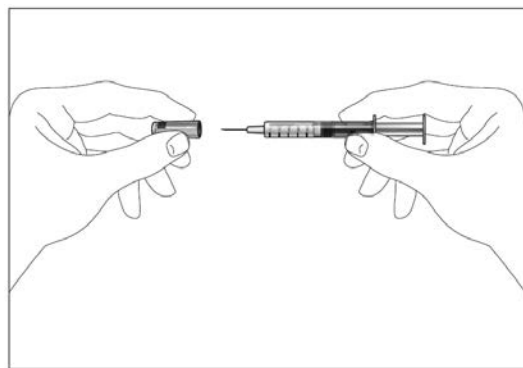

6

3. You may notice small air bubbles in the pre-filled syringe. If there are air bubbles present, hold the syringe with the needle pointing upwards (see picture 7), gently tap the syringe with your fingers until the air bubbles rise to the top of the syringe. With the syringe pointing upwards, expel all air from the syringe by pushing the plunger slowly upwards.

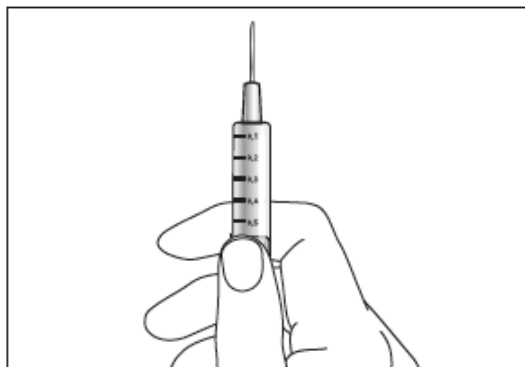

7

4. You can now use the pre-filled syringe.

How you should inject yourself or your child

1. Pinch the disinfected skin between your thumb and forefinger, without squeezing it (see picture 8).
2. Put the needle fully into the skin as shown by your doctor or nurse. The angle between the syringe and skin should not be too narrow (at least 45°, see picture 9).
3. Inject the liquid into the tissue slowly and evenly, always keeping the skin pinched.
4. After injecting the liquid, remove the needle and let go of the skin.
5. Press the injection site with a piece of gauze bandage or a sterile gauze swab for several seconds.
6. Only use each syringe for one injection. Do not use any Lonquex that is left in the syringe.

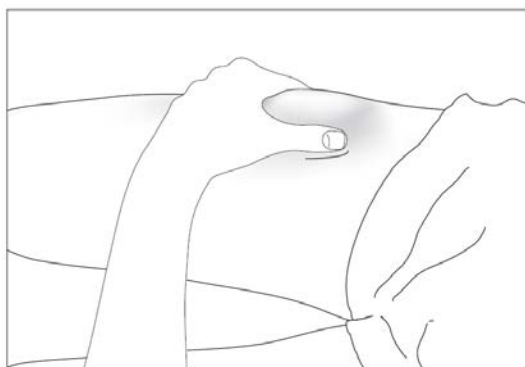

8

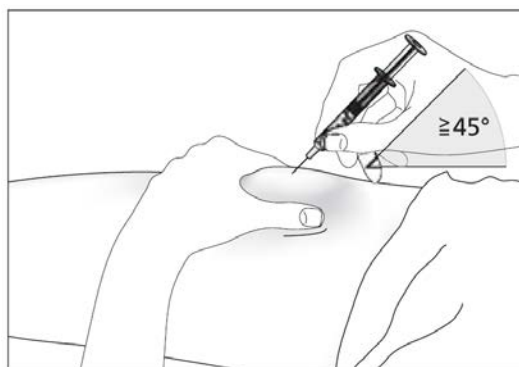

9

Remember

If you have any problems, please ask your doctor or nurse for help and advice.

Disposing of used syringes

- Do not put the cover back on used needles.
- Put used syringes into the puncture-proof container and keep this container out of the sight and reach of children.
- Dispose of the full puncture-proof container as instructed by your doctor, pharmacist or nurse.
- Never put the syringes that you have used into your normal household rubbish bin.

Information for injecting yourself or your child

This section contains information on how to give yourself or your child an injection of Lonquex under the skin. It is important that you do not try to give yourself or your child the injection unless you have received special training from your doctor or nurse. If you are not sure about giving yourself the injection or you have any questions, please ask your doctor or nurse for help.

How Lonquex is used

You will need to give yourself or your child the injection into the tissue just under the skin. This is known as a subcutaneous injection.

Equipment that you need

To give yourself or your child an injection into the tissue under the skin you will need:

- a pre-filled syringe of Lonquex,
- an alcohol wipe,
- a piece of gauze bandage or a sterile gauze swab.

What you should do before the injection

1. Take the medicine out of the refrigerator.
2. Open the blister and take the pre-filled syringe out of the blister (see picture 1). Do not pick up the pre-filled syringe by the plunger or needle cover. This could damage the safety device.
3. Check the expiry date on the pre-filled syringe label (EXP). Do not use it if the date has passed the last day of the month shown.
4. Check the appearance of Lonquex. It must be a clear and colourless liquid. If there are particles in it or if it is cloudy, you must not use it.
5. Do not shake Lonquex vigorously as this may affect its activity.
6. For a more comfortable injection:
 - let the pre-filled syringe stand for 30 minutes to reach room temperature (not above 25 °C) or
 - hold the pre-filled syringe gently in your hand for a few minutes.

Do **not** warm Lonquex in any other way (for example, do not warm it in a microwave or in hot water).
7. Do **not** remove the needle cover from the syringe until you are ready to inject.
8. Find a comfortable, well-lit place. Put everything you need within easy reach (the Lonquex pre-filled syringe, an alcohol wipe and a piece of gauze bandage or a sterile gauze swab).

9. **Wash your hands thoroughly.**

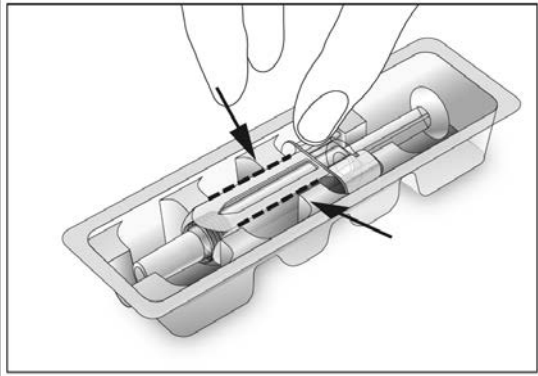

1

Where the injection should be given

The most suitable places for the injection are:

- the top of the thighs,
- the abdomen (see grey areas in picture 2) avoiding the skin directly surrounding the navel.

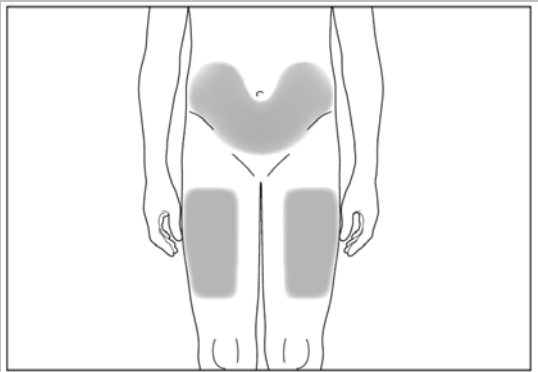

2

If someone else is injecting you or if you are injecting your child, the following places can also be used:

- the back and side of the upper arms (see grey areas in pictures 3 and 4).

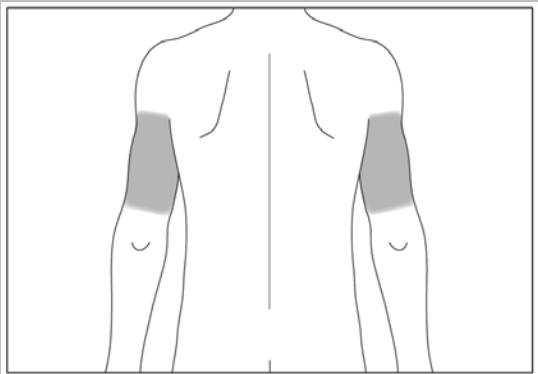

3

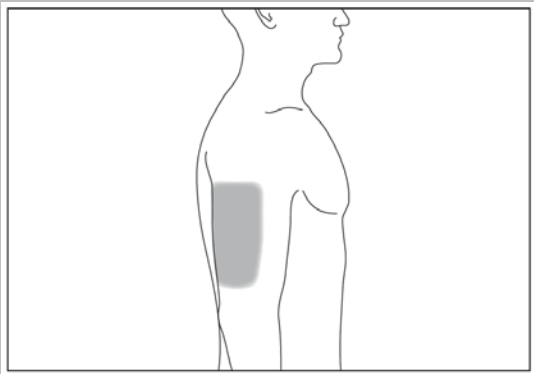

4

How to prepare for the injection

Before you give yourself or your child a Lonquex injection, you must do the following:

1. Disinfect the injection site on the skin by using an alcohol wipe.
2. Hold the syringe and gently remove the cover from the needle without twisting. Pull straight as shown in pictures 5 and 6. Do not touch the needle or push the plunger.

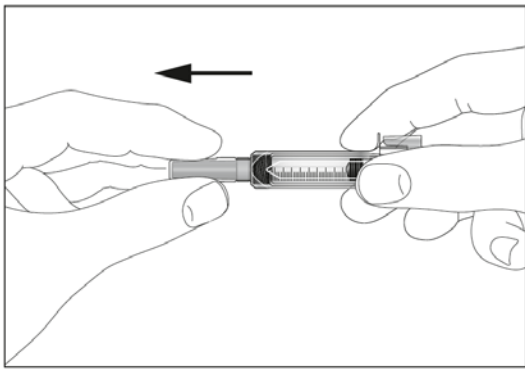

5

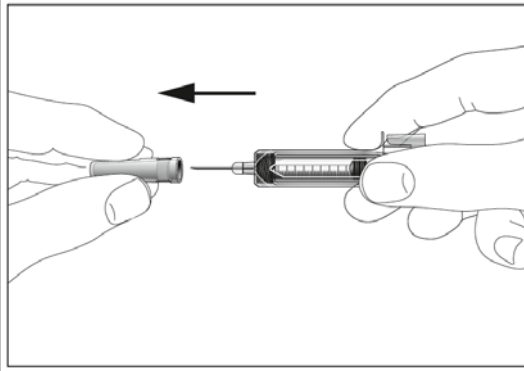

6

3. You may notice small air bubbles in the pre-filled syringe. If there are air bubbles present, hold the syringe with the needle pointing upwards (see picture 7), gently tap the syringe with your fingers until the air bubbles rise to the top of the syringe. With the syringe pointing upwards, expel all air from the syringe by pushing the plunger slowly upwards.

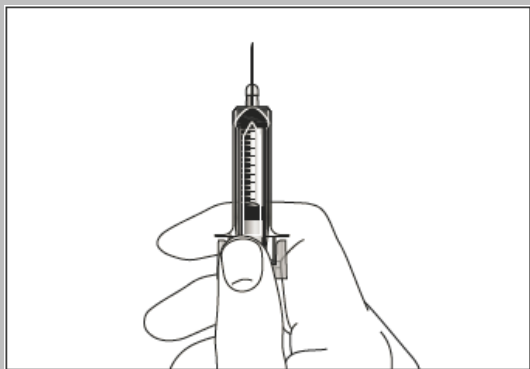

7

4. You can now use the pre-filled syringe.

How you should inject yourself or your child

1. Pinch the disinfected skin between your thumb and forefinger, without squeezing it (see picture 8).
2. Put the needle fully into the skin as shown by your doctor or nurse. The angle between the syringe and skin should not be too narrow (at least 45°, see picture 9).
3. Inject the liquid into the tissue slowly and evenly, always keeping the skin pinched (see picture 10).
4. Push the plunger as far as it will go to inject all the liquid. While the plunger is still pressed all the way down, remove the needle from the skin (see picture 11). Then release the plunger. The safety device will be activated immediately. The entire needle and syringe will be drawn back automatically and covered so that you cannot prick yourself (see picture 12).
5. Press the injection site with a piece of gauze bandage or a sterile gauze swab for several seconds.
6. Each pre-filled syringe is for single use only.

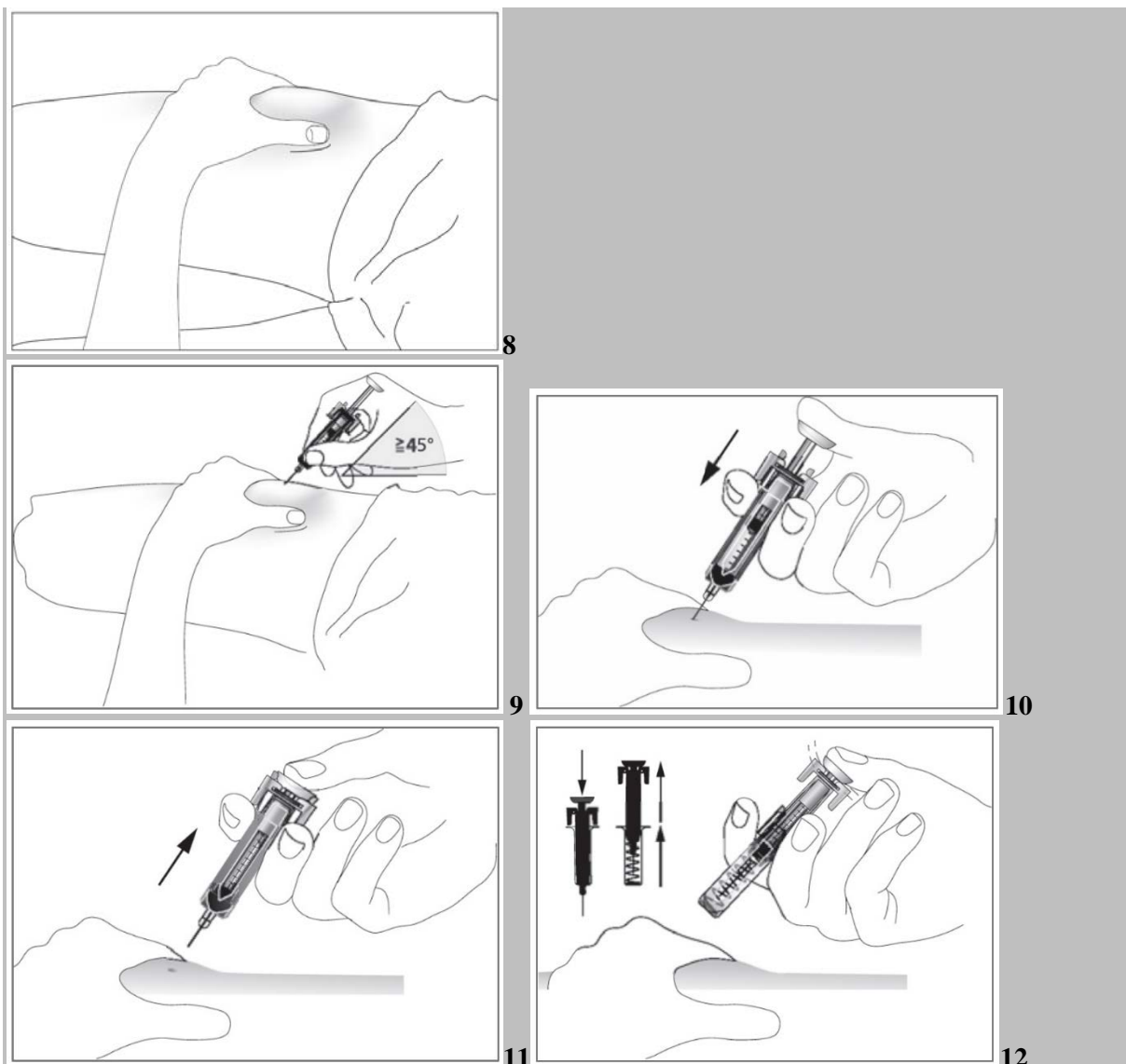

Remember

If you have any problems, please ask your doctor or nurse for help and advice.

If you use more Lonquex than you should

If you use more Lonquex than you should, talk to your doctor.

If you forget to use Lonquex

If you have missed an injection, contact your doctor to discuss when you should inject the next dose.

If you have any further questions on the use of this medicine, ask your doctor, pharmacist or nurse.

4. Possible side effects

Like all medicines, this medicine can cause side effects, although not everybody gets them.

Most serious side effects

- Allergic reactions such as skin rash, raised itchy areas of skin and serious allergic reactions with weakness, drop in blood pressure, difficulty breathing and swelling of the face have been reported uncommonly (may affect up to 1 in 100 people). If you think you are having this type of reaction, you must stop your Lonquex injection and get medical help immediately.

- Increased spleen size has been reported uncommonly and cases of splenic ruptures have been reported with other medicines similar to Lonquex. Some cases of splenic rupture were fatal. It is important to contact your doctor immediately if you experience ***pain in the upper left side of the abdomen or left shoulder pain*** since this may relate to a problem with your spleen.
- Cough, fever and difficult or painful breathing can be signs of uncommon serious pulmonary side effects, such as pneumonia and acute respiratory distress syndrome, which may be fatal. If you have a fever or any of these symptoms, it is important to contact your doctor immediately.
- It is important to contact your doctor immediately if you have any of the following symptoms: swelling or puffiness, which may be associated with passing water less frequently, difficulty breathing, abdominal swelling and feeling of fullness, and a general feeling of tiredness. These symptoms generally develop in a rapid fashion.
These could be symptoms of a condition reported with frequency not known (cannot be estimated from the available data), called “capillary leak syndrome”, which causes blood to leak from the small blood vessels into your body and needs urgent medical attention.

Other side effects

Very common (may affect more than 1 in 10 people)

- Musculoskeletal pains such as bone pain and pain in the joints, muscles, limbs, chest, neck or back. Tell your doctor if you experience severe musculoskeletal pain.
- Nausea.

Common (may affect up to 1 in 10 people)

- Reduction in blood platelets, which increases risk of bleeding or bruising.
- Headache.
- Skin reactions, such as redness or rash.
- Low blood levels of potassium, which can cause muscle weakness, twitching or abnormal heart rhythm.
- Chest pain.
- Coughing up blood.

Uncommon (may affect up to 1 in 100 people)

- Rise in white blood cells.
- Local reactions at the injection site, such as pain or hardening.
- Some changes may occur in your blood, but these will be detected by routine blood tests.
- Bleeding from the lung.

Not known (frequency cannot be estimated from the available data):

- Inflammation of the aorta (the large blood vessel which transports blood from the heart to the body), see section 2.

Side effects that have been seen with similar medicines, but not yet with Lonquex

- Sickle cell crises in patients with sickle cell anaemia.
- Plum-coloured raised painful sores on the limbs and sometimes the face and neck with fever (Sweet’s syndrome).
- Inflammation of the blood vessels in the skin.
- Damage to the tiny filters inside your kidneys (glomerulonephritis; see section 2 under “Warnings and precautions”).

Reporting of side effects

If you get any side effects, talk to your doctor, pharmacist or nurse. This includes any possible side effects not listed in this leaflet. You can also report side effects directly via **the national reporting system listed in Appendix V**. By reporting side effects you can help provide more information on the safety of this medicine.

5. How to store Lonquex

Keep this medicine out of the sight and reach of children.

Do not use this medicine after the expiry date which is stated on the outer carton and on the label of the pre-filled syringe after EXP. The expiry date refers to the last day of that month.

Store in a refrigerator (2 °C – 8 °C).

Do not freeze.

Keep the pre-filled syringe in the outer carton, in order to protect from light.

Lonquex may be removed from the refrigerator and stored below 25 °C for a maximum single period of up to 7 days. Once removed from the refrigerator, the medicine must be used within this period or disposed of.

Do not use this medicine if you notice that it is cloudy or there are particles in it.

Do not throw away any medicines via wastewater or household waste. Ask your pharmacist how to throw away medicines you no longer use. These measures will help protect the environment.

6. Contents of the pack and other information

What Lonquex contains

- The active substance is lipegfilgrastim. Each pre-filled syringe contains 6 mg lipegfilgrastim. Each ml solution contains 10 mg lipegfilgrastim.
- The other ingredients (excipients) are glacial acetic acid, sodium hydroxide (see section 2 “Lonquex contains sodium”), sorbitol (E420) (see section 2 “Lonquex contains sorbitol”), polysorbate 20 and water for injections.

What Lonquex looks like and contents of the pack

Lonquex is a solution for injection (injection) in pre-filled syringe with a fixed injection needle in a blister. Lonquex is a clear and colourless solution. If there are particles in it or if it is cloudy, you must not use it.

Each pre-filled syringe contains 0.6 ml solution.

Lonquex is available in packs containing 1 and 4 pre-filled syringes with safety device or 1 pre-filled syringe without safety device.

Not all pack sizes may be marketed.

Marketing Authorisation Holder

Teva B.V.
Swensweg 5
2031 GA Haarlem
Netherlands

Manufacturer

Merckle GmbH,
Graf-Arco-Straße 3
89079 Ulm
Germany

For any information about this medicine, please contact the local representative of the Marketing Authorisation Holder:

België/Belgique/Belgien

Teva Pharma Belgium N.V./S.A./AG
Tél/Tel: +32 38207373

България

Тева Фарма ЕАД
Тел.: +359 24899585

Česká republika

Teva Pharmaceuticals CR, s.r.o.
Tel: +420 251007111

Danmark

Teva Denmark A/S
Tlf.: +45 44985511

Deutschland

TEVA GmbH
Tel: +49 73140208

Eesti

UAB Teva Baltics Eesti filiaal
Tel: +372 6610801

Ελλάδα

TEVA HELLAS A.E.
Τηλ: +30 2118805000

España

Teva Pharma, S.L.U.
Tel: +34 915359180

France

Teva Santé
Tél: +33 155917800

Hrvatska

Pliva Hrvatska d.o.o.
Tel: +385 13720000

Ireland

Teva Pharmaceuticals Ireland
Tel: +44 2075407117

Ísland

Alvogen ehf.
Sími: +354 5222900

Italia

Teva Italia S.r.l.
Tel: +39 028917981

Κύπρος

TEVA HELLAS A.E.

Lietuva

UAB Teva Baltics
Tel: +370 52660203

Luxembourg/Luxemburg

Teva Pharma Belgium N.V./S.A./AG
Belgique/Belgien
Tél/Tel: +32 38207373

Magyarország

Teva Gyógyszergyár Zrt.
Tel.: +36 12886400

Malta

TEVA HELLAS A.E.
il-Greċja
Tel: +30 2118805000

Nederland

Teva Nederland B.V.
Tel: +31 8000228400

Norge

Teva Norway AS
Tlf: +47 66775590

Österreich

ratiopharm Arzneimittel Vertriebs-GmbH
Tel: +43 1970070

Polska

Teva Pharmaceuticals Polska Sp. z o.o.
Tel.: +48 223459300

Portugal

Teva Pharma - Produtos Farmacêuticos, Lda.
Tel: +351 214767550

România

Teva Pharmaceuticals S.R.L.
Tel: +40 212306524

Slovenija

Pliva Ljubljana d.o.o.
Tel: +386 15890390

Slovenská republika

TEVA Pharmaceuticals Slovakia s.r.o.
Tel: +421 257267911

Suomi/Finland

Teva Finland Oy
Puh/Tel: +358 201805900

Sverige

Teva Sweden AB

Ελλάδα
Τηλ: +30 2118805000

Tel: +46 42121100

Latvija

UAB Teva Baltics filiāle Latvijā
Tel: +371 67323666

This leaflet was last revised in {month YYYY}.

Detailed information on this medicine is available on the European Medicines Agency web site:
<http://www.ema.europa.eu>.

Package leaflet: Information for the patient

Lonquex 6 mg/0.6 ml solution for injection lipegfilgrastim

Read all of this leaflet carefully before you are given this medicine because it contains important information for you.

- Keep this leaflet. You may need to read it again.
- If you have any further questions, ask your doctor, pharmacist or nurse.
- If you get any side effects, talk to your doctor, pharmacist or nurse. This includes any possible side effects not listed in this leaflet. See section 4.

What is in this leaflet

1. What Lonquex is and what it is used for
2. What you need to know before Lonquex is given
3. How Lonquex is given
4. Possible side effects
5. How to store Lonquex
6. Contents of the pack and other information

1. What Lonquex is and what it is used for

What Lonquex is

Lonquex contains the active substance lipegfilgrastim. Lipegfilgrastim is a long-acting modified protein produced by biotechnology in bacteria called *Escherichia coli*. It belongs to a group of proteins called cytokines and is similar to a natural protein (granulocyte-colony stimulating factor [G-CSF]) produced by your own body.

What Lonquex is used for

Lonquex is used in adults and in children aged 2 years and older.

Your doctor has prescribed Lonquex for you or for your child in order to reduce the duration of a condition called neutropenia (low white blood cell count) and the occurrence of febrile neutropenia (low white blood cell count with a fever). These can be caused by the use of cytotoxic chemotherapy (medicines that destroy rapidly-growing cells).

How Lonquex works

Lipegfilgrastim stimulates the bone marrow (the tissue where new blood cells are made) to produce more white blood cells. White blood cells are important as they help your body fight infection. These cells are very sensitive to the effects of chemotherapy which can cause the number of these cells in your body to decrease. If white blood cells fall to a low level, there may not be enough left in the body to fight bacteria and you may have an increased risk of infection.

2. What you need to know before Lonquex is given

Lonquex must not be used

- if you or your child are allergic to lipegfilgrastim or any of the other ingredients of this medicine (listed in section 6).

Warnings and precautions

Talk to your doctor, pharmacist or nurse before using Lonquex:

- if you or your child get left upper abdominal pain or pain at the tip of your shoulder. It could be a consequence of a spleen disorder (see section 4 "Possible side effects").

- if you or your child have a cough, fever and difficulty breathing. It could be a consequence of a pulmonary disorder (see section 4 “Possible side effects”).
- if you or your child have sickle cell anaemia, which is an inherited disease characterised by sickle-shaped red blood cells.
- if you or your child have previously experienced allergic reactions to other medicines like this one (e.g. filgrastim, lenograstim or pegfilgrastim of the group of G-CSFs). There could be a risk of reacting to Lonquex too.

Your doctor will carry out regular blood tests in order to monitor various blood components and their levels. Your doctor will also check your or your child’s urine regularly as other medicines similar to this one (e.g. other granulocyte colony stimulating factors such as filgrastim, lenograstim or pegfilgrastim) can possibly harm the tiny filters inside your kidneys (glomerulonephritis; see section 4 “Possible side effects”).

Tell your doctor if you or your child are being treated for breast or lung cancer in combination with chemotherapy and/or radiation therapy and experience symptoms such as tiredness, fever, and easy bruising or bleeding. These symptoms could be a consequence of a precancerous blood condition called myelodysplastic syndrome (MDS) or of a blood cancer called acute myeloid leukaemia (AML) which have been associated with another medicine like this one (pegfilgrastim of the group of G-CSFs).

Inflammation of the aorta (the large blood vessel which transports blood from the heart to the body) has been reported rarely with other medicines like this one (e.g. filgrastim, lenograstim or pegfilgrastim of the group of G-CSFs). The symptoms can include fever, abdominal pain, malaise, back pain and increased inflammatory markers. Tell your doctor if you experience these symptoms.

Children and adolescents

Lonquex is not recommended for children younger than 2 years of age.

Other medicines and Lonquex

Tell your doctor or pharmacist if you or your child are using, have recently used or might use any other medicines.

Pregnancy and breast-feeding

Lonquex has not been tested in pregnant women. It is important to tell your doctor if you are pregnant, think you may be pregnant or are planning to have a baby, as the doctor may decide that you should not use this medicine.

It is unknown whether the active substance in this medicine passes into the breast milk. You should therefore interrupt breast-feeding during treatment.

Driving and using machines

Lonquex has no or negligible influence on your ability to drive and use machines.

Lonquex contains sorbitol

This medicine contains 30 mg sorbitol in each vial.

Lonquex contains sodium

This medicine contains less than 1 mmol sodium (23 mg) per vial, that is to say essentially ‘sodium-free’.

3. How Lonquex is given

Lonquex is normally given by a doctor or a nurse. The injection is given into the tissue just under the skin (subcutaneous injection).

What the recommended dose is

The recommended dose for adults is 6 mg (one 0.6 ml vial) once per chemotherapy cycle.

The recommended dose for children and adolescents is based on their body weight:

Body weight (kg)	Dose (once per chemotherapy cycle)
< 10	0.6 mg (0.06 ml)
≥ 10 to < 20	1.5 mg (0.15 ml)
≥ 20 to < 30	2.5 mg (0.25 ml)
≥ 30 to < 45	4.0 mg (0.40 ml)
≥ 45	6.0 mg (0.60 ml)

Lonquex is also available as a 6 mg pre-filled syringe for adults and any children weighing 45 kg and more.

When will Lonquex be given

The Lonquex dose will normally be injected approximately 24 hours after the last dose of chemotherapy at the end of each chemotherapy cycle.

If you have any further questions on the use of this medicine, ask your doctor, pharmacist or nurse.

4. Possible side effects

Like all medicines, this medicine can cause side effects, although not everybody gets them.

Most serious side effects

- Allergic reactions such as skin rash, raised itchy areas of skin and serious allergic reactions with weakness, drop in blood pressure, difficulty breathing and swelling of the face have been reported uncommonly (may affect up to 1 in 100 people). If you think you are having this type of reaction, you must stop your Lonquex injection and get medical help immediately.
- Increased spleen size has been reported uncommonly and cases of splenic ruptures have been reported with other medicines similar to Lonquex. Some cases of splenic rupture were fatal. It is important to contact your doctor immediately if you experience ***pain in the upper left side of the abdomen or left shoulder pain*** since this may relate to a problem with your spleen.
- Cough, fever and difficult or painful breathing can be signs of uncommon serious pulmonary side effects, such as pneumonia and acute respiratory distress syndrome, which may be fatal. If you have a fever or any of these symptoms, it is important to contact your doctor immediately.
- It is important to contact your doctor immediately if you have any of the following symptoms: swelling or puffiness, which may be associated with passing water less frequently, difficulty breathing, abdominal swelling and feeling of fullness, and a general feeling of tiredness. These symptoms generally develop in a rapid fashion.
These could be symptoms of a condition reported with frequency not known (cannot be estimated from the available data), called “capillary leak syndrome”, which causes blood to leak from the small blood vessels into your body and needs urgent medical attention.

Other side effects

Very common (may affect more than 1 in 10 people)

- Musculoskeletal pains such as bone pain and pain in the joints, muscles, limbs, chest, neck or back. Tell your doctor if you experience severe musculoskeletal pain.
- Nausea.

Common (may affect up to 1 in 10 people)

- Reduction in blood platelets, which increases risk of bleeding or bruising.

- Headache.
- Skin reactions, such as redness or rash.
- Low blood levels of potassium, which can cause muscle weakness, twitching or abnormal heart rhythm.
- Chest pain.
- Coughing up blood.

Uncommon (may affect up to 1 in 100 people)

- Rise in white blood cells.
- Local reactions at the injection site, such as pain or hardening.
- Some changes may occur in your blood, but these will be detected by routine blood tests.
- Bleeding from the lung.

Not known (frequency cannot be estimated from the available data):

- Inflammation of the aorta (the large blood vessel which transports blood from the heart to the body), see section 2.

Side effects that have been seen with similar medicines, but not yet with Lonquex

- Sick cell crises in patients with sick cell anaemia.
- Plum-coloured raised painful sores on the limbs and sometimes the face and neck with fever (Sweet's syndrome).
- Inflammation of the blood vessels in the skin.
- Damage to the tiny filters inside your kidneys (glomerulonephritis; see section 2 under "Warnings and precautions").

Reporting of side effects

If you get any side effects, talk to your doctor, pharmacist or nurse. This includes any possible side effects not listed in this leaflet. You can also report side effects directly via [the national reporting system listed in Appendix V](#). By reporting side effects you can help provide more information on the safety of this medicine.

5. How to store Lonquex

Keep this medicine out of the sight and reach of children.

Do not use this medicine after the expiry date which is stated on the outer carton and on the vial label after EXP. The expiry date refers to the last day of that month.

Store in a refrigerator (2 °C – 8 °C).

Do not freeze.

Keep the vial in the outer carton, in order to protect from light.

Lonquex may be removed from the refrigerator and stored below 25 °C for a maximum single period of up to 7 days. Once removed from the refrigerator, the medicine must be used within this period or disposed of.

This medicine must not be used if it is cloudy or there are particles in it.

6. Contents of the pack and other information

What Lonquex contains

- The active substance is lipegfilgrastim. Each ml of solution contains 10 mg lipegfilgrastim. Each vial of 0.6 ml contains 6 mg lipegfilgrastim
- The other ingredients (excipients) are glacial acetic acid, sodium hydroxide (see section 2 “Lonquex contains sodium”), sorbitol (E420) (see section 2 “Lonquex contains sorbitol”), polysorbate 20 and water for injections.

What Lonquex looks like and contents of the pack

Lonquex is a solution for injection (injection) supplied in a glass vial as a clear and colourless solution.

Lonquex is available in packs containing 1 or 6 vials.

Not all pack sizes may be marketed.

Marketing Authorisation Holder

Teva B.V.
Swensweg 5
2031 GA Haarlem
Netherlands

Manufacturer

Merckle GmbH,
Graf-Arco-Straße 3
89079 Ulm
Germany

For any information about this medicine, please contact the local representative of the Marketing Authorisation Holder:

België/Belgique/Belgien

Teva Pharma Belgium N.V./S.A./AG
Tél/Tel: +32 38207373

Lietuva

UAB Teva Baltics
Tel: +370 52660203

България

Тева Фарма ЕАД
Тел.: +359 24899585

Luxembourg/Luxemburg

Teva Pharma Belgium N.V./S.A./AG
Belgique/Belgien
Tél/Tel: +32 38207373

Česká republika

Teva Pharmaceuticals CR, s.r.o.
Tel: +420 251007111

Magyarország

Teva Gyógyszergyár Zrt.
Tel.: +36 12886400

Danmark

Teva Denmark A/S
Tlf.: +45 44985511

Malta

TEVA HELLAS A.E.
il-Greċja
Tel: +30 2118805000

Deutschland

TEVA GmbH
Tel: +49 73140208

Nederland

Teva Nederland B.V.
Tel: +31 8000228400

Eesti

UAB Teva Baltics Eesti filiaal
Tel: +372 6610801

Norge

Teva Norway AS
Tlf: +47 66775590

Ελλάδα

TEVA HELLAS A.E.

Österreich

ratiopharm Arzneimittel Vertriebs-GmbH

Τηλ: +30 2118805000

España

Teva Pharma, S.L.U.
Tel: +34 915359180

France

Teva Santé
Tél: +33 155917800

Hrvatska

Pliva Hrvatska d.o.o.
Tel: +385 13720000

Ireland

Teva Pharmaceuticals Ireland
Tel: +44 2075407117

Ísland

Alvogen ehf.
Sími: +354 5222900

Italia

Teva Italia S.r.l.
Tel: +39 028917981

Κύπρος

TEVA HELLAS A.E.
Ελλάδα
Τηλ: +30 2118805000

Latvija

UAB Teva Baltics filiāle Latvijā
Tel: +371 67323666

Tel: +43 1970070

Polska

Teva Pharmaceuticals Polska Sp. z o.o.
Tel.: +48 223459300

Portugal

Teva Pharma - Produtos Farmacêuticos, Lda.
Tel: +351 214767550

România

Teva Pharmaceuticals S.R.L.
Tel: +40 212306524

Slovenija

Pliva Ljubljana d.o.o.
Tel: +386 15890390

Slovenská republika

TEVA Pharmaceuticals Slovakia s.r.o.
Tel: +421 257267911

Suomi/Finland

Teva Finland Oy
Puh/Tel: +358 201805900

Sverige

Teva Sweden AB
Tel: +46 42121100

This leaflet was last revised in {month YYYY}.

Detailed information on this medicine is available on the European Medicines Agency web site:
<http://www.ema.europa.eu>.

The following information is intended for medical or healthcare professionals only:

Storage and inspection

Store in a refrigerator (2 °C – 8 °C). Do not freeze. Keep the vial in the outer carton, in order to protect from light.

The solution should be allowed to reach a comfortable temperature (15 °C – 25 °C) before the injection.

Once removed from the refrigerator Lonquex may be stored below 25 °C for a maximum single period of up to 7 days.

The solution should be visually inspected before use. Only clear, colourless solutions without particles should be used.

Vigorous shaking should be avoided. Excessive shaking may aggregate lipegfilgrastim, rendering it biologically inactive.

Method of administration

The recommended dose is to be injected subcutaneously (SC) using an appropriate syringe with adequate graduation for the prescribed dose.

The injection should be given into the abdomen, upper arm or thigh.

Lonquex is for single use only. Unused portions of each vial must be discarded properly. Do not save any unused portions for later administration.

Lonquex must not be mixed with other medicinal products.

Procedure for proper disposal

Any unused product, any items that come into contact with the product and waste material must be disposed of in accordance with local requirements.