

**ANNEX I**  
**SUMMARY OF PRODUCT CHARACTERISTICS**

▼ This medicinal product is subject to additional monitoring. This will allow quick identification of new safety information. Healthcare professionals are asked to report any suspected adverse reactions. See section 4.8 for how to report adverse reactions.

## 1. NAME OF THE MEDICINAL PRODUCT

OXERVATE 20 micrograms/ml eye drops, solution

## 2. QUALITATIVE AND QUANTITATIVE COMPOSITION

One ml of solution contains 20 micrograms of cenegermin\*.

\* Recombinant form of human nerve growth factor produced in *Escherichia Coli*.

For the full list of excipients, see section 6.1.

## 3. PHARMACEUTICAL FORM

Eye drops, solution (eye drops).

Clear, colourless solution. pH 7.0-7.4 and osmolarity 280-320 mOsm/kg.

## 4. CLINICAL PARTICULARS

### 4.1 Therapeutic indications

Treatment of moderate (persistent epithelial defect) or severe (corneal ulcer) neurotrophic keratitis in adults.

### 4.2 Posology and method of administration

Treatment should be initiated and supervised by an ophthalmologist or a healthcare professional qualified in ophthalmology.

#### Posology

##### *Adults:*

The recommended dose is one drop of OXERVATE in the conjunctival sac of the affected eye(s), 6 times a day at 2 hourly intervals, starting from the morning and within 12 hours. Treatment should be continued for eight weeks.

Patients with an eye infection should be treated before starting therapy with OXERVATE (see section 4.4).

If a dose is missed, treatment should be continued as normal, at the next scheduled administration. The missed dose can be administered later, within the 12 hours shelf-life of the daily vial. Patients should be advised not to instil more than one drop in the affected eye(s) during any administration.

#### Special populations

##### *Elderly:*

No dose adjustment is required in patients 65 years of age and older.

*Hepatic and renal impairment:*

The medicinal product has not been studied in patients with hepatic or renal impairment. However, no dose adjustment is considered necessary in these populations.

*Paediatric population:*

The safety and efficacy of this medicinal product in children and adolescents below the age of 18 years have not been established. No data are available.

Method of administration

For ocular use only.

*Precautions to be taken before administering the medicinal product:*

Patients should be instructed to wash their hands before use.

OXERVATE should only be administered using the associated delivery system (vial adapter and pipettes), according to the instructions presented in section 6.6.

An individual pipette should be used per application.

If more than one topical ophthalmic product is being used, the eye drops must be administered at least 15 minutes apart, to avoid diluting the other product. If eye ointment, gel or other viscous eye drops are used, they should be administered 15 minutes following OXERVATE treatment (see also section 4.5).

In case of concomitant use with contact lenses, see section 4.4.

For instructions on preparation and handling of the medicinal product before administration, see section 6.6.

### **4.3 Contraindications**

Hypersensitivity to the active substance or to any of the excipients listed in section 6.1.

### **4.4 Special warnings and precautions for use**

Risk of corneal melting or impending perforation

It is important that the risk of corneal melting or impending perforation, and the need to undergo emergency surgery or another procedure is assessed before starting therapy with OXERVATE as cenegermin should not be used in patients requiring immediate surgery.

Eye reactions

OXERVATE may cause mild to moderate eye discomfort, such as eye pain, to the patient. The patient should be advised to contact the doctor in case of concern or a more severe eye reaction.

Use of corticosteroids or eye drops containing preservatives

Use of ophthalmic topical agents known to inhibit epithelial healing, including corticosteroids or eye drops containing preservatives such as benzalkonium chloride, polyquaternium-1, benzododecinium bromide, cetrimide and other quaternary ammonium derivatives, should be avoided during treatment of neurotrophic keratitis, as they could interfere with corneal healing (see section 4.5).

Eye infections

An eye infection should be treated before use of OXERVATE. Should an eye infection occur, OXERVATE should be suspended until infection resolution (see section 4.2).

### Ocular cancer

Cenegermin may theoretically affect ocular cancer, as it is a growth factor. OXERVATE should be used with caution in patients with ocular cancer. It is recommended that these patients continue to be monitored for cancer progression during and after treatment with this medicinal product.

### Contact lenses

Patients should be instructed to remove contact lenses before applying OXERVATE and to wait 15 minutes after instillation of the dose before reinsertion, because the presence of a contact lens (either therapeutic or corrective) could theoretically limit the distribution of cenegermin onto the area of the corneal lesion.

## **4.5 Interaction with other medicinal products and other forms of interaction**

Other topical ophthalmic products may be used during treatment with OXERVATE when used 15 minutes apart, with the exception of agents known to inhibit epithelial healing (e.g. corticosteroids or eye drops containing preservatives such as benzalkonium chloride, polyquaternium-1, benzododecinium bromide, cetrimide and other quaternary ammonium derivatives) (see sections 4.2 and 4.4). If eye ointment, gel or other viscous eye drops are used, OXERVATE should be administered first.

No interaction studies with other medicinal products have been performed.

As systemic absorption of cenegermin after use of the medicinal product is negligible or not detectable, no drug interactions are anticipated.

## **4.6 Fertility, pregnancy, and lactation**

### Pregnancy

There are no data from the use of cenegermin in pregnant women. Animal studies with cenegermin do not indicate direct or indirect harmful effects with respect to reproductive toxicity when administered subcutaneously (see section 5.3).

Systemic exposure to cenegermin is negligible or does not occur.

As a precautionary measure, it is preferable to avoid the use of OXERVATE during pregnancy.

### Breastfeeding

It is not known whether cenegermin is excreted in human milk.

A risk to the suckling child cannot be excluded.

A decision must be made whether to discontinue breast-feeding or to discontinue/abstain from this therapy taking into account the benefit of breast feeding for the child and the benefit of therapy for the woman.

### Fertility

There are no data on the effects of cenegermin on human fertility.

## **4.7 Effects on ability to drive and use machines**

The treatment has minor influence on the ability to drive and use machines, as it may cause temporary blurred vision or other visual disturbances, which is expected to last a few minutes after instillation. If

blurred vision occurs at instillation, the patient must wait until the vision clears before driving or using machines.

## 4.8 Undesirable effects

### Summary of the safety profile

The most commonly reported adverse reactions in patients suffering from neurotrophic keratitis and treated with OXERVATE during clinical studies include eye pain (11.1 %), eye inflammation (8.3 %), which may include anterior chamber inflammation and hyphaema; lacrimation increased (5.6 %), with symptoms such as eye discharge; eyelid pain (5.6 %) and foreign body sensation in the eye (5.6 %).

Eye pain was the most frequently reported adverse reaction, followed by eye irritation and abnormal sensation in the eye, when considering the whole population treated with the medicinal product (i.e. population included in clinical trials also on indications other than neurotrophic keratitis).

### Tabulated list of adverse reactions

The following adverse reactions listed below were observed in clinical studies in patients suffering from neurotrophic keratitis, treated with OXERVATE 20 µg/ml.

Adverse drug reactions are presented below according to MedDRA system organ classification (SOC and Preferred Term Level).

They are ranked according to system organ class and classified according to the following convention: very common ( $\geq 1/10$ ), common ( $\geq 1/100$  to  $< 1/10$ ), uncommon ( $\geq 1/1,000$  to  $< 1/100$ ), rare ( $\geq 1/10,000$  to  $< 1/1,000$ ), very rare ( $< 1/10,000$ ), or not known (cannot be estimated from the available data).

System organ class	Frequency	Adverse reaction
Infections and infestations	Uncommon	Corneal abscess
Nervous system disorders	Common	Headache
Eye disorders	Very common	Eye pain
	Common	Eye inflammation, eyelid pain, foreign body sensation in the eye, lacrimation increased, blepharitis, conjunctival hyperaemia, photophobia, eye irritation
	Uncommon	Corneal neovascularization

### Reporting of suspected adverse reactions

Reporting suspected adverse reactions after authorisation of the medicinal product is important. It allows continued monitoring of the benefit/risk balance of the medicinal product. Healthcare professionals are asked to report any suspected adverse reactions via **the national reporting system listed in [Appendix V](#)**.

## 4.9 Overdose

A topical overdose is not likely to occur or to be associated with toxicity. A topical overdose of cenegermin may be flushed from the eye(s) with lukewarm water.

## 5. PHARMACOLOGICAL PROPERTIES

### 5.1 Pharmacodynamic properties

Pharmacotherapeutic Group: {not yet assigned}, ATC code: {not yet assigned}.

## Mechanism of action

OXERVATE contains cenegeermin, a recombinant form of human nerve growth factor.

Nerve growth factor is an endogenous protein involved in the differentiation and maintenance of neurons, which acts through specific high-affinity (i.e., TrkA) and low-affinity (i.e. p75NTR) nerve growth factor receptors. Nerve growth factor receptors are expressed in the anterior segment of the eye (cornea, conjunctiva, iris, ciliary body, and lens), by the lacrimal gland, and by posterior segment intraocular tissues. The treatment with cenegeermin, administered as eye drops, is intended to allow restoration of corneal integrity.

## Clinical efficacy and safety

The efficacy and safety of OXERVATE were evaluated in two multicentre, randomised, double-masked, vehicle-controlled clinical studies (NGF0212 and NGF0214) in patients with moderate (persisted epithelial defect) or severe (corneal ulcer) neurotropic keratitis refractory to non-surgical treatments. In both studies patients received OXERVATE or vehicle 6 times daily in the affected eye(s) for 8 weeks, and underwent a follow-up period.

Study NGF0214 enrolled 48 patients (mean age 65±14 years, range 33-94 years) treated with OXERVATE 20 µg/ml or vehicle (24 patients per arm). Study NGF0212 enrolled a total of 174 patients (mean age 61±16 years, range 18-95 years), who have been exposed to OXERVATE and vehicle without the L-methionine excipient; 156 patients were assessed independently for efficacy, comparing two different dosages of the medicinal product with 20 and 10 µg/ml cenegeermin to vehicle (52 patients per arm).

The table below summarizes the results for complete corneal healing of the persistent epithelial defect or corneal ulcer (the primary endpoint, defined as the greatest diameter of corneal fluorescein staining <0.5 mm) after 4 and 8 weeks of treatment for patients who received OXERVATE 20 µg/ml or vehicle in the two studies.

<b>Results after 4 and 8 weeks of treatment</b>		<b>Study NGF0214</b>		<b>Study NGF0212</b>	
		<b>Week 4</b>	<b>Week 8</b>	<b>Week 4</b>	<b>Week 8</b>
Complete corneal healing rate	OXERVATE	56.5 %	69.6 %	58.0 %	74.0 %
	vehicle	37.5 %	29.2 %	19.6 %	43.1 %
	(p value)	(0.191)	(0.006)	(0.001)	(0.002)

The percentage of patients experiencing complete corneal clearing (grade 0 on the modified Oxford scale), the least squares mean change in best corrected distance visual acuity score (Early Treatment Diabetic Retinopathy Study letters) from baseline and any improvement in corneal sensitivity as measured in millimetres by Cochet-Bonnet aesthesiometry (difference compared to baseline >0) was also measured after 8 weeks of treatment in both studies, and summarized in the table below.

<b>Results after 8 weeks of treatment</b>		<b>Study NGF0214</b>	<b>Study NGF0212</b>
Complete corneal clearing	OXERVATE	22.7 %	21.4 %
	Vehicle	4.2 %	10.0 %
	(p value)	(0.062)	(0.157)
Best corrected distance visual acuity	OXERVATE	6.11	11.9
	Vehicle	3.53	6.9
	(p value)	(0.143)	(0.213)
Corneal sensitivity inside lesion	OXERVATE	72.2 %	76.3 %
	Vehicle	60.0 %	68.4 %
	(p value)	(0.458)	(0.442)

Patients considered completely healed at the end of 8 weeks of treatment with OXERVATE did not tend to have recurrences within the 12 months follow-up period of study NGF0212. Specifically, more than 80 % of the 31 patients who were healed after initial OXERVATE 20 µg/ml treatment and for

whom a response was available, remained completely healed at the end of the 12 months follow up period.

### Paediatric population

The European Medicines Agency has deferred the obligation to submit the results of studies with the medicinal product in one or more subsets of the paediatric population in neurotrophic keratitis (see section 4.2 for information on paediatric use).

## **5.2 Pharmacokinetic properties**

### Absorption

Cenegermin is mostly removed from the eye with the tear production and through the naso-lacrimal duct; the minor portion that is absorbed occurs mostly in the conjunctiva and peri-orbital tissue and to a minor extent through the cornea following ocular administration.

Pharmacokinetic profiling of patients included in studies found no accumulation effect of cenegermin. In general, the systemic absorption of OXERVATE is negligible.

### Distribution

After eye drop administration, cenegermin is distributed particularly in the anterior portion of the eye, although a study with radiolabelled cenegermin in rats has shown that it also reaches the retina and other posterior parts of the eye at doses significantly higher than those administered by eye drops in humans to treat neurotrophic keratitis. At the ocular doses, cenegermin is not distributed throughout body tissues as there is no systemic absorption above the natural baseline levels.

### Biotransformation

Ocular administered cenegermin is mainly eliminated by tear secretion and the remainder mostly biotransformed by local tissue proteases.

### Elimination

Cenegermin administered by eye drops is mostly eliminated with the tear secretion.

## **5.3 Preclinical safety data**

Nonclinical data reveal no hazard for humans based on conventional studies of safety pharmacology (central nervous system), single-dose toxicity, repeat-dose toxicity and toxicity to reproduction, embryo-foetal development, pre- and post-natal development using ocular (eye drop), intravenous, and/or subcutaneous administration.

## **6. PHARMACEUTICAL PARTICULARS**

### **6.1 List of Excipients**

Trehalose dihydrate  
Mannitol  
Disodium hydrogen phosphate, anhydrous  
Sodium dihydrogen phosphate, dihydrate  
Hydroxypropylmethylcellulose  
Polyethylene glycol 6000  
L-Methionine  
Water for injections  
Hydrochloric acid

Sodium hydroxide  
Nitrogen

## **6.2 Incompatibilities**

Not applicable

## **6.3 Shelf life**

### Unopened vial

2 years.

### Opened vial

Once opened, the product must be stored below 25 °C and used within 12 hours at 25 °C. From a microbiological point of view, the method of opening (i.e. by connecting the vial adapter to the vial) precludes the risk of microbial contamination.

## **6.4 Special precautions for storage**

### OXERVATE vials

#### *Pharmacy:*

The weekly carton containing the vials must be stored in a freezer (-20 °C ±5 °C).

#### *Patient:*

The patient will receive a weekly carton including 7 vials of OXERVATE in an insulated pack. As soon as the patient is at home (and no later than 5 hours from when the patient receives the product at the pharmacy), the weekly carton should be placed into the refrigerator, at 2-8 °C. It should be noted that the frozen medicinal product received from the pharmacy could need up to 30 minutes for thawing.

An individual multi-dose vial of OXERVATE is to be removed from the fridge for use over the course of a single day. Each opened vial can be stored in the fridge or below 25 °C, but must be used within 12 hours.

After this period of time the vial contents should be discarded irrespective of whether some residual product remains in the vial.

## **6.5 Nature and contents of container**

1 ml OXERVATE solution in sterile, preservative-free multi-dose Type I glass vials, closed with a rubber stopper and an aluminium overseal with a polypropylene flip-off cap, presented in cardboard cartons.

Pack size: 7 multi-dose vials per carton

The patient will receive a weekly carton containing 7 vials of OXERVATE.

This medicinal product should only be used with specific vial adapters and disposable devices (pipettes) that will be provided separately from the weekly OXERVATE carton.

7 vial adapters (i.e. 1 per day), 42 pipettes (i.e. 6 per day) and 42 disinfectant wipes (i.e. 6 per day) sufficient to administer the medicinal product for one week will be provided separately, together with a dose recording card. Extra adapter (1), pipettes (3) and wipes (3) will also be provided as spares.

## **6.6 Special precautions for disposal and other handling**

The patient will receive a weekly carton containing 7 multi-dose vials of OXERVATE, which should be stored in a refrigerator until the day of use.



The patient will also receive separately vial adapters, pipettes and disinfectant wipes.

An individual multi-dose vial of OXERVATE should be taken from the refrigerator at the same time each morning bearing in mind the 12 hour treatment schedule. The multi-dose vial containing the product should be prepared according to the following instructions:

- 1) With clean freshly-washed hands, place the vial on a steady flat surface and remove the plastic flip-off cap.
- 2) Peel-off the back of the vial adapter blister pack.
- 3) Without removing the vial adapter from its blister pack, connect the vial adapter to the vial by firmly pushing the vial adapter down vertically until it snaps into place over the neck of the vial and the spike of the vial adapter pierces through the vial's rubber stopper. Once the vial adapter has been connected correctly, it should not be removed from the vial.
- 4) Remove and discard the vial adapter blister pack. Avoid touching the surface of the adapter.

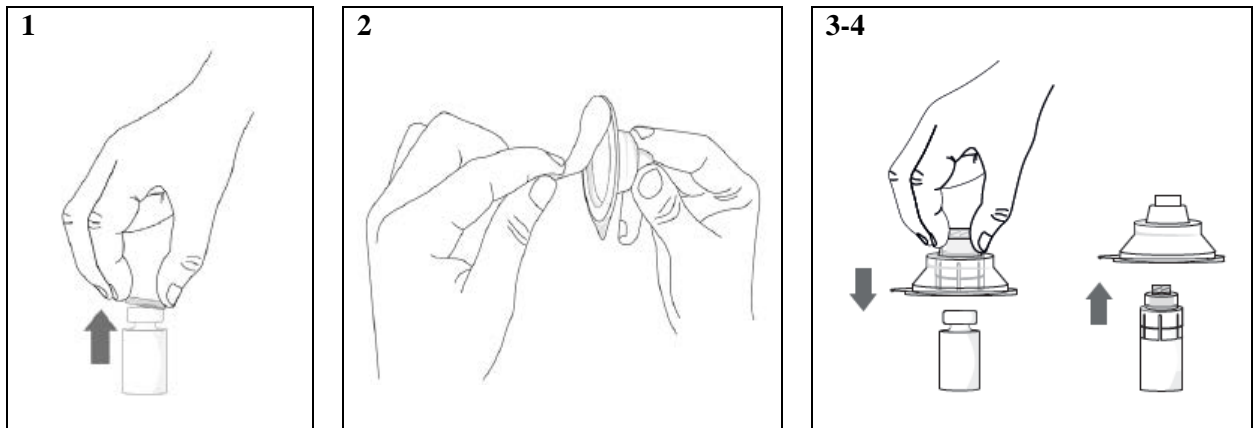

To withdraw and administer each dose of OXERVATE solution, the steps below should be followed:

- 5) Take an individual disinfectant wipe and gently clean the surface of the valve on the luer lock connector of the vial adapter. After cleaning, the valve should be allowed to dry for approximately one minute.
- 6) Take a pipette and remove it from the protective packaging.
- 7) Screw the pipette clockwise into the luer lock connector of the vial adapter.
- 8) Ensure that the pipette plunger is pushed all the way down.
- 9) Turn the vial upside-down with the pipette connected and gently pull the pipette plunger outwards until it stops, to draw the solution into the pipette (ensure that the plunger has reached the stop point).
- 10) Check the pipette and confirm that it contains some of the solution. Air bubbles may cause blockage and prevent the pipette from filling properly (especially at first withdrawal). If the pipette is empty, keep the vial with the connected pipette upside-down, push the plunger all the way in and pull it out again.
- 11) Once it has been correctly filled, unscrew the pipette from the luer lock connector of the vial adapter.

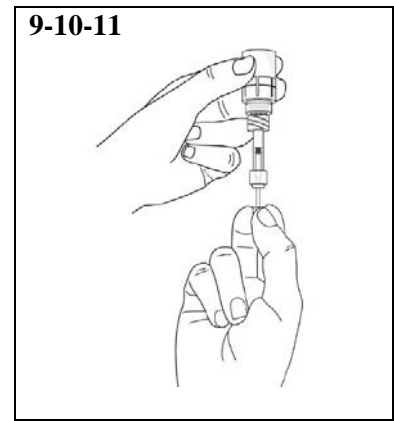
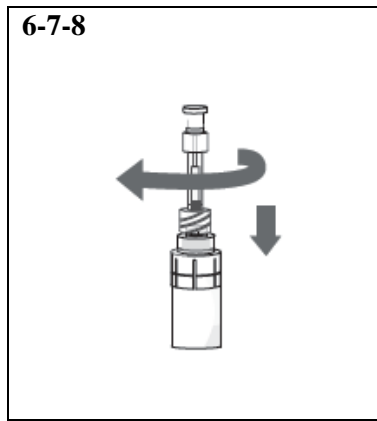
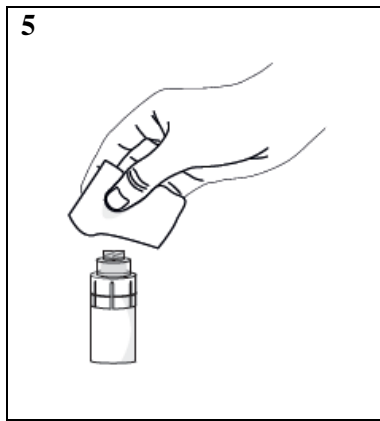

- 12) Hold the pipette, pointing down, between the middle finger and thumb, tilt the head back and position the pipette above the affected eye. Pull down the lower eyelid. Gently push the pipette plunger in until a single drop is instilled into the conjunctival fornix.
- 13) Immediately discard the used pipette and wipe after instillation.
- 14) If a mistake is made and a drop is not instilled into the eye, repeat the steps described above using a new pipette and wipe.
- 15) Throughout the day, the vial can either be placed back in the fridge after each use or stored below 25 °C (with the vial adapter still connected).

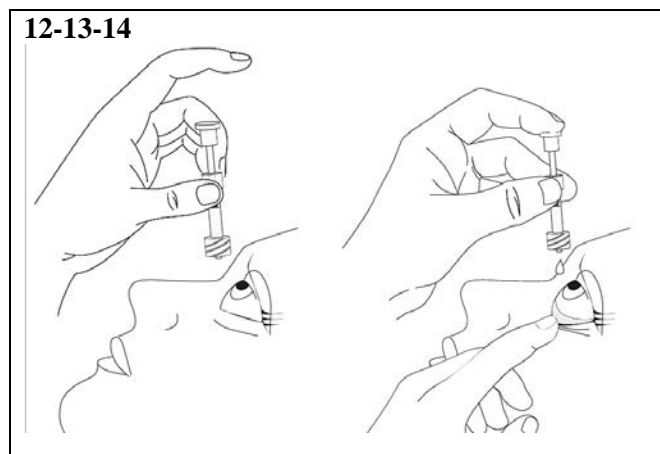

The administration instructions above (steps 5 to 15) should be repeated every 2 hours (six times per day) using a new disinfectant wipe and a new pipette each time.

The vial and any remaining solution must be discarded at the end of the day, and no later than 12 hours from the time the vial adapter was connected (irrespective of whether any residual solution remains in the vial).

To ensure accurate dosing every 2 hours, the patient should be advised to set an alarm as a reminder for dosing.

To control that six doses have been taken every day, the patient should be advised to use the weekly dose recording card provided with the delivery system. On that card the patient should track the date of the first use of the weekly supply, the time of the vial opening (i.e. when the vial adapter is connected to the vial), and the time of daily ocular instillations occurring over the week.

A new OXERVATE supply will be issued each week for the duration of the treatment period.

Any unused medicinal product or waste material should be disposed of in accordance with local requirements.

**7. MARKETING AUTHORISATION HOLDER**

Dompé farmaceutici S.p.A.  
Via Santa Lucia, 6  
20122 Milano - Italy  
Tel. +39 02 583831  
Fax +39 02 58383215  
E-mail: [info@dompe.com](mailto:info@dompe.com)

**8. MARKETING AUTHORISATION NUMBER(S)**

EU/1/17/1197/001

**9. DATE OF FIRST AUTHORISATION/RENEWAL OF THE AUTHORISATION**

Date of first authorisation: {DD month YYYY}

**10. DATE OF REVISION OF THE TEXT**

Detailed information on this medicinal product is available on the website of the European Medicines Agency: <http://www.ema.europa.eu>.

## **ANNEX II**

- A. MANUFACTURER(S) OF THE BIOLOGICAL ACTIVE SUBSTANCE(S) AND MANUFACTURER(S) RESPONSIBLE FOR BATCH RELEASE**
- B. CONDITIONS OR RESTRICTIONS REGARDING SUPPLY AND USE**
- C. OTHER CONDITIONS AND REQUIREMENTS OF THE MARKETING AUTHORISATION**
- D. CONDITIONS OR RESTRICTIONS WITH REGARD TO THE SAFE AND EFFECTIVE USE OF THE MEDICINAL PRODUCT**

**A. MANUFACTURER(S) OF THE BIOLOGICAL ACTIVE SUBSTANCE(S) AND MANUFACTURER(S) RESPONSIBLE FOR BATCH RELEASE**

Name and address of the manufacturer(s) of the biological active substance(s)

DOMPE' farmaceutici S.p.A.  
Via Campo di Pile,  
67100 L'Aquila, Italy

Name and address of the manufacturer(s) responsible for batch release

DOMPE' farmaceutici S.p.A.  
Via Campo di Pile,  
67100 L'Aquila, Italy

**B. CONDITIONS OR RESTRICTIONS REGARDING SUPPLY AND USE**

Medicinal product subject to restricted medical prescription (see Annex I: Summary of Product Characteristics, section 4.2).

**C. OTHER CONDITIONS AND REQUIREMENTS OF THE MARKETING AUTHORISATION**

• **Periodic Safety Update Reports**

The requirements for submission of periodic safety update reports for this medicinal product are set out in the list of Union reference dates (EURD list) provided for under Article 107c(7) of Directive 2001/83/EC and any subsequent updates published on the European medicines web-portal. The marketing authorisation holder shall submit the first periodic safety update report for this product within 6 months following authorisation.

**D. CONDITIONS OR RESTRICTIONS WITH REGARD TO THE SAFE AND EFFECTIVE USE OF THE MEDICINAL PRODUCT**

• **Risk Management Plan (RMP)**

The MAH shall perform the required pharmacovigilance activities and interventions detailed in the agreed RMP presented in Module 1.8.2 of the marketing authorisation and any agreed subsequent updates of the RMP.

An updated RMP should be submitted:

- At the request of the European Medicines Agency;
- Whenever the risk management system is modified, especially as the result of new information being received that may lead to a significant change to the benefit/risk profile or as the result of an important (pharmacovigilance or risk minimisation) milestone being reached.

**ANNEX III**  
**LABELLING AND PACKAGE LEAFLET**

## **A. LABELLING**

**PARTICULARS TO APPEAR ON THE OUTER PACKAGING**

**OUTER CARTON – VIAL**

**1. NAME OF THE MEDICINAL PRODUCT**

OXERVATE 20 micrograms/ml eye drops, solution  
cenegermin

**2. STATEMENT OF ACTIVE SUBSTANCE**

1 ml of solution contains 20 micrograms of cenegermin.

**3. LIST OF EXCIPIENTS**

Excipients: trehalose dihydrate, mannitol, disodium hydrogen phosphate anhydrous, sodium dihydrogen phosphate dihydrate, hydroxypropylmethyl cellulose, polyethylene glycol 6000, L-methionine, water for injections, hydrochloric acid, sodium hydroxide, nitrogen.

**4. PHARMACEUTICAL FORM AND CONTENTS**

Eye drops, solution.  
7 multi-dose vials

**5. METHOD AND ROUTE OF ADMINISTRATION**

Use only with the vial adapters, pipettes and disinfectant wipes provided separately.  
Read the package leaflet before use.  
Ocular use.

**6. SPECIAL WARNING THAT THE MEDICINAL PRODUCT MUST BE STORED OUT OF THE SIGHT AND REACH OF CHILDREN**

Keep out of the sight and reach of children.

**7. OTHER SPECIAL WARNING(S), IF NECESSARY**

Remove contact lenses before use.

**8. EXPIRY DATE**

EXP

**9. SPECIAL STORAGE CONDITIONS**

Pharmacist: Store in a freezer until dispensing.



Patient: Store in a refrigerator for a maximum of 7 days. Once a vial is opened store below 25 °C or store in a refrigerator. The opened vial must be used within 12 hours of first opening.

**10. SPECIAL PRECAUTIONS FOR DISPOSAL OF UNUSED MEDICINAL PRODUCTS OR WASTE MATERIALS DERIVED FROM SUCH MEDICINAL PRODUCTS, IF APPROPRIATE**

Discard any remaining solution at the end of each day.

**11. NAME AND ADDRESS OF THE MARKETING AUTHORISATION HOLDER**

Dompé farmaceutici S.p.A.  
Via Santa Lucia 6  
20122 Milano  
Italy

**12. MARKETING AUTHORIZATION NUMBERS**

EU/1/17/1197/001

**13. BATCH NUMBER**

Lot

**14. GENERAL CLASSIFICATION FOR SUPPLY**

**15. INSTRUCTION ON USE**

**16. INFORMATION IN BRAILLE**

oxervate

**17. UNIQUE IDENTIFIER - 2D BARCODE**

2D barcode carrying the unique identifier included.

**18. UNIQUE IDENTIFIER - HUMAN READABLE DATA**

PC: {number}  
SN: {number}  
NN: {number}

**MINIMUM PARTICULARS TO APPEAR ON SMALL IMMEDIATE PACKAGING UNITS**

**LABEL - MULTI-DOSE VIAL**

**1. NAME OF THE MEDICINAL PRODUCT AND ROUTE(S) OF ADMINISTRATION**

OXERVATE 20 µg/ml eye drops  
cenegermin  
Ocular use

**2. METHOD OF ADMINISTRATION**

**3. EXPIRY DATE**

EXP

**4. BATCH NUMBER**

Lot

**5. CONTENTS BY WEIGHT, BY VOLUME OR BY UNIT**

1 ml

**6. OTHER**

**B. PACKAGE LEAFLET**

## Package leaflet: Information for the patient

### OXERVATE 20 micrograms/ml eye drops, solution cenegermin

▼ This medicine is subject to additional monitoring. This will allow quick identification of new safety information. You can help by reporting any side effects you may get. See the end of section 4 for how to report side effects.

**Read all of this leaflet carefully before you start using this medicine because it contains important information for you.**

- Keep this leaflet. You may need to read it again.
- If you have any further questions, ask your doctor or pharmacist.
- This medicine has been prescribed for you only. Do not pass it on to others. It may harm them, even if their signs of illness are the same as yours.
- If you get any side effects, talk to your doctor or pharmacist. This includes any possible side effects not listed in this leaflet. See section 4.

#### What is in this leaflet

1. What OXERVATE is and what it is used for
2. What you need to know before you use OXERVATE
3. How to use OXERVATE
4. Possible side effects
5. How to store OXERVATE
6. Contents of the pack and other information

#### 1. What OXERVATE is and what it is used for

OXERVATE contains the active ingredient cenegermin. Cenegermin is a type of nerve growth factor (a human protein) which is naturally present on the eye surface.

OXERVATE is used to treat adults with moderate or severe 'neurotrophic keratitis'. This is a disease affecting the cornea (the transparent layer in the front part of the eye) which causes defects on the outer surface of the cornea that do not heal naturally or corneal ulcers.

OXERVATE is intended to allow the healing of the cornea.

#### 2. What you need to know before you use OXERVATE

##### Do not use OXERVATE:

- if you are allergic to cenegermin or any of the other ingredients of this medicine (listed in section 6).

##### Warnings and precautions

Only use this medicine in your affected eye(s).

Talk to your doctor **before** using this medicine:

- if you have an infection in your eye, as the infection should be treated first. If you get an eye infection **whilst** using OXERVATE, you should stop your treatment and consult your doctor for advice straightaway.
- if you have an eye cancer, because this medicine might worsen your cancer.
- if you are taking any eye drops containing corticosteroids (e.g. to treat an ocular inflammation) or preservatives (e.g. benzalkonium chloride, polyquaternium-1, benzododecinium bromide, cetrimide). Eye drops containing these substances could slow down or interfere with the healing of your eye and should therefore be avoided during treatment with this medicine.

Treatment with OXERVATE may cause you mild to moderate eye discomfort such as eye pain. If you experience a severe eye reaction seek medical advice from your doctor.

Contact lenses could interfere with the correct use of this medicine. If you wear contact lenses remove them before using this medicine and **wait 15 minutes after** using this medicine before reinserting them.

### **Children and adolescents**

This medicine should not be used in children and adolescents below 18 years of age, as there is not enough information about its use in this age group.

### **Other medicines and OXERVATE**

Tell your doctor or pharmacist if you are using, have recently used or might use any other medicines.

You should wait **at least 15 minutes before or after** using OXERVATE if you use any other eye drops. This will help to avoid one eye drop diluting the other eye drop. If you also use an eye ointment or gel or an eye drop with a thick consistency, you should use OXERVATE **first**, and then wait **at least 15 minutes before** using the other medicine.

### **Pregnancy and breast-feeding**

If you are pregnant or breast-feeding, think you may be pregnant or are planning to have a baby, ask your doctor or pharmacist for advice before using this medicine.

The use of this medicine should be avoided during pregnancy. Talk to your doctor if you are pregnant or think you may be pregnant.

It is not known if this medicine passes into breast milk. Talk to your doctor before breast-feeding your baby, as a decision must be made whether to stop breast-feeding or to avoid or stop OXERVATE therapy.

### **Driving and using machines**

Your vision may be temporarily blurred immediately after using this medicine. If this happens, wait until your vision clears before you drive or use machines.

## **3. How to use OXERVATE**

Always use this medicine exactly as your doctor or pharmacist has told you. Check with your doctor or pharmacist if you are not sure.

**The recommended dose** is 1 drop in the affected eye 6 times a day at 2-hourly intervals, starting in the morning (i.e. 6 drops per day within 12 hours). You should continue your treatment for 8 weeks.

### **Instructions for use**

Follow these instructions carefully and ask your doctor or pharmacist if there is anything you do not understand.

Ocular use.

You will receive an insulated container containing a weekly carton of OXERVATE and a separate delivery system (composed of medical devices intended for withdrawing and administering the medicine).

The weekly carton contains 7 vials of OXERVATE (1 vial per day of the week). Remove the weekly carton of OXERVATE from the insulated container and store it in a fridge as soon as you can (and in any case no later than 5 hours from when you receive the medicine from your pharmacist). Since at the pharmacy this medicine is stored in a freezer, in case treatment is started right away after receiving the weekly carton, you will have to wait until the first vial is thawed (this could take up to 30 minutes).

Take an individual vial of this medicine from the fridge in the morning (always at the same time each morning), and prepare it in the following way:

- Wash your hands.
- If you wear contact lenses, take them out before using the drops.
- Remove the plastic flip-off cap from the vial (**picture 1**).
- Peel-off the back of the vial adapter blister pack (**picture 2**).
- Without removing the vial adapter from its blister pack, connect it to the vial by firmly pushing it down until it snaps into place over the neck of the vial. The spike of the vial adapter should pierce through the vial's rubber stopper. Once the vial adapter has been connected correctly, it should not be removed from the vial (**picture 3**).
- Remove and discard the packaging of the vial adapter.

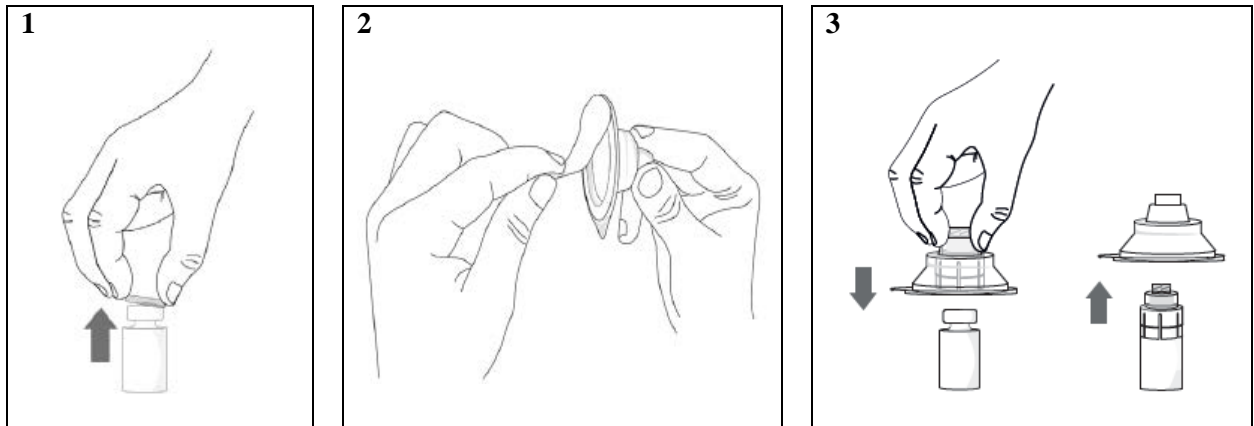

The multi-dose vial of OXERVATE is now ready for use (1 drop in the affected eye every 2 hours six times a day). The vial can be stored in the fridge or below 25 °C throughout the day, but should not be frozen.

To withdraw and administer each dose of this medicine, follow the steps below:

- Take a single disinfectant wipe and gently clean the surface of the valve on the connector part of the vial adapter (**picture 4**). After cleaning, wait for approximately 1 minute to allow the valve to dry.
- Take a pipette (dropper) and remove it from its protective packaging.
- Screw the pipette (clockwise) into the connector part of the vial adapter (**picture 5**).
- Ensure that the pipette plunger is pushed all the way down.
- Turn the vial upside-down (with the pipette still connected) and gently pull the plunger until it stops, to draw the solution into the pipette. Ensure the plunger has reached the stop point (**picture 6**).

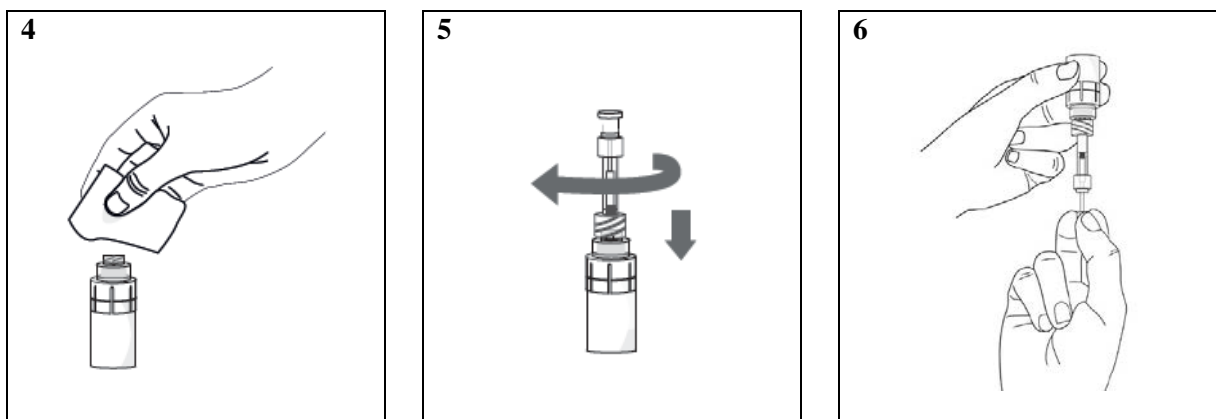

- Check the pipette to ensure it contains the eye drops, solution. Air bubbles may cause blockage and prevent the pipette from filling properly (especially at first withdrawal). If the pipette is

empty, keep the vial with the connected pipette upside-down, push the plunger all the way in and pull it out again.

- Once it has been correctly filled, unscrew the pipette from the connector part of the vial adapter.
- Holding the pipette, pointing down, between your middle finger and thumb, tilt your head back and position the pipette above your affected eye. Pull down your lower eyelid, folding between the inner eyelid and the eyeball. Gently push the plunger in until a single drop is dropped into the conjunctival fornix (**picture 7**). Make sure you do not touch your eye with the tip of the pipette.
- With your head still tilted back, blink a few times so that the medicine covers the surface of your eye.
- Immediately discard the used pipette after use, even if there is still some liquid left in it.
- If a drop misses your eye, try again, using a new pipette and wipe.
- After each use throughout the day, place the vial back in the fridge (or keep it below 25 °C) for the rest of the day, with the vial adapter still connected.

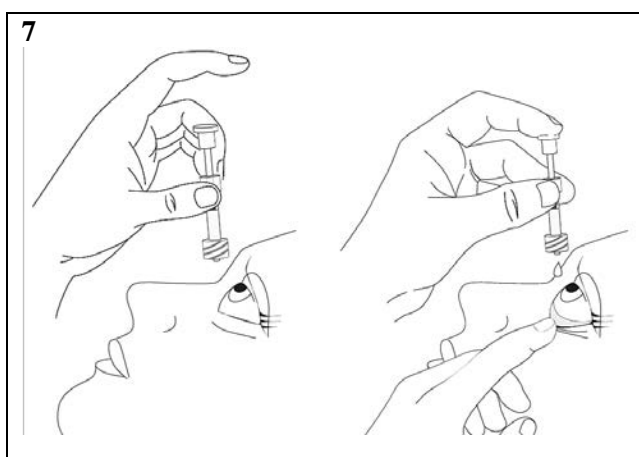

Repeat the above process (from picture 4 onwards) every 2 hours 6 times a day. Use a new disinfectant wipe and a new pipette each time.

If you use drops in both eyes, repeat the above instructions for your other eye using a new pipette (in this case, you will need to use 2 vials per day).

Discard the used vial at the end of each day (even if there is still some liquid left in it), and in any case no later than 12 hours from the time you connected the vial adapter to it.

You will receive a new supply of OXERVATE each week, for the duration of the treatment period. To ensure accurate dosing every 2 hours, you could set an alarm as a reminder for dosing.

To control that six doses have been taken at the end of each treatment day, you should use the weekly dose recording card provided with the delivery system. On that card you should write down the date of the first use of the weekly supply, the time of the vial opening (i.e. when you connect the vial adapter to the vial) and track each time you use an eye drop of this medicine, over the week.

#### **If you use more OXERVATE than you should**

If you use more than you should, flush the affected eye with lukewarm water. Do not put in any more drops until it is time for your next regular dose. Using more OXERVATE than is recommended is not likely to be harmful. Continue with your next dose as scheduled.

#### **If you forget to use OXERVATE**

Continue with your next dose as scheduled. Do not use a double dose to make up for the forgotten dose. You can give the missed dose 2 hours after your last scheduled dose of the day, provided this is still within 12 hours from first opening the daily vial. Do not use more than 6 drops each day in the affected eye(s).

**If you stop using OXERVATE**

The lesion or ulcer in your eye will worsen and could lead to infections or impaired vision. Speak to your doctor first if you intend to stop using OXERVATE.

If you have any further questions on the use of this medicine, ask your doctor or pharmacist.

**4. Possible side effects**

Like all medicines, this medicine can cause side effects, although not everybody gets them.

The majority of side effects occur generally in and around the eyes.

The following side effects have been reported:

**Very common (may affect more than 1 in 10 people)**

- eye pain.

**Common (may affect up to 1 in 10 people)**

- inflammation of the eye;
- pain in the eyelid;
- abnormal sensation and discomfort in the eye, including feeling that there is something in the eye;
- increase of tears (this could include symptoms such as discharge in the eye);
- inflammation of the eyelid with itching and redness;
- redness of the conjunctiva (mucous membrane that covers the front of the eye and lines the inside of the eyelids);
- sensitivity to light;
- irritation in or around the eye;
- headache.

**Uncommon (may affect up to 1 in 100 people)**

- excessive ingrowth of blood vessels into the cornea;
- infection of the cornea with pus and swelling.

**Reporting of side effects**

If you get any side effects, talk to your doctor or pharmacist. This includes any possible side effects not listed in this leaflet. You can also report side effects directly via [the national reporting system listed in Appendix V](#). By reporting side effects you can help provide more information on the safety of this medicine.

**5. How to store OXERVATE**

Keep this medicine out of the sight and reach of children.

Do not use this medicine after the expiry date which is stated on the outer carton and vial label after "EXP". The expiry date refers to the last day of that month.

Store the weekly carton containing 7 vials of OXERVATE in the fridge (2-8 °C).

After the vial adapter is connected to the vial, it can be stored in the fridge or below 25 °C. Discard the used vial at the end of the day (even if there is still some liquid left in it), and in any case no later than 12 hours from the time you connected the vial adapter to it.



The pipettes included in the delivery system are single-use only. Each pipette should be discarded immediately after using, even if there is still some liquid left in it.

Do not throw away any medicines via wastewater or household waste. Ask your pharmacist how to throw away medicines you no longer use. These measures will help protect the environment.

## **6. Contents of the pack and other information**

### **What OXERVATE contains**

- The active substance is cenegermin. 1 ml of OXERVATE contains 20 micrograms of cenegermin.
- The other ingredients are trehalose dihydrate, mannitol, disodium hydrogen phosphate anhydrous, sodium dihydrogen phosphate dihydrate, hydroxypropylmethyl cellulose, polyethylene glycol 6000, L-methionine and water for injections, hydrochloric acid and sodium hydroxide and nitrogen.

### **What OXERVATE looks like and contents of the pack**

OXERVATE is a clear, colourless eye drops, solution.

It is supplied in multi-dose glass vials.

Each vial contains 1 ml eye drops, solution.

The vials are contained in a weekly cardboard carton containing 7 vials.

7 vial adapters, 42 pipettes, 42 disinfectant wipes and a dose recording card are provided separately from the vials. Extra adapter (1), pipettes (3) and wipes (3) are included as spares.

Pack size: 7 multi-dose vials.

### **Marketing Authorisation Holder**

Dompé farmaceutici S.p.A.  
Via Santa Lucia, 6  
20122 Milano  
Italy

### **Manufacturer**

Dompé farmaceutici S.p.A.  
Via Campo di Pile  
67100 L'Aquila  
Italy

### **This leaflet was last revised in**

Detailed information on this medicine is available on the European Medicines Agency web site:

<http://www.ema.europa.eu>.