

**ANNEX I**  
**SUMMARY OF PRODUCT CHARACTERISTICS**

Medicinal product no longer authorised

▼ This medicinal product is subject to additional monitoring. This will allow quick identification of new safety information. Healthcare professionals are asked to report any suspected adverse reactions. See section 4.8 for how to report adverse reactions.

## 1. NAME OF THE MEDICINAL PRODUCT

Ristempa 6 mg solution for injection.

## 2. QUALITATIVE AND QUANTITATIVE COMPOSITION

Each pre-filled syringe contains 6 mg of pegfilgrastim\* in 0.6 ml solution for injection. The concentration is 10 mg/ml based on protein only\*\*.

\*Produced in *Escherichia coli* cells by recombinant DNA technology followed by conjugation with polyethylene glycol (PEG).

\*\* The concentration is 20 mg/ml if the PEG moiety is included.

The potency of this product should not be compared to the potency of another pegylated or non-pegylated protein of the same therapeutic class. For more information, see section 5.1

Excipient(s) with known effect:

Each pre-filled syringe contains 30 mg sorbitol (E420)

Each pre-filled syringe contains less than 1 mmol (23 mg) sodium (see section 4.4).

For the full list of excipients, see section 6.1.

## 3. PHARMACEUTICAL FORM

Solution for injection.

Clear, colourless solution for injection.

## 4. CLINICAL PARTICULARS

### 4.1 Therapeutic indications

Reduction in the duration of neutropenia and the incidence of febrile neutropenia in adult patients treated with cytotoxic chemotherapy for malignancy (with the exception of chronic myeloid leukaemia and myelodysplastic syndromes).

### 4.2 Posology and method of administration

Ristempa therapy should be initiated and supervised by physicians experienced in oncology and/or haematology.

#### Posology

One 6 mg dose (a single pre-filled syringe) of Ristempa is recommended for each chemotherapy cycle, given at least 24 hours after cytotoxic chemotherapy.

### Method of administration

Ristempa is injected subcutaneously. The injections should be given into the thigh, abdomen or upper arm. For instructions on handling of the medicinal product before administration, see section 6.6.

### Paediatric population

The safety and efficacy of Ristempa in children has not yet been established. Currently available data are described in sections 4.8, 5.1 and 5.2 but no recommendation on a posology can be made

### Patients with renal impairment

No dose change is recommended in patients with renal impairment, including those with end stage renal disease.

## **4.3 Contraindications**

Hypersensitivity to the active substance or to any of the excipients.

## **4.4 Special warnings and precautions for use**

Limited clinical data suggest a comparable effect on time to recovery of severe neutropenia for pegfilgrastim to filgrastim in patients with *de novo* acute myeloid leukaemia (see section 5.1). However, the long-term effects of Ristempa have not been established in acute myeloid leukaemia; therefore, it should be used with caution in this patient population.

Granulocyte-colony stimulating factor can promote growth of myeloid cells *in vitro* and similar effects may be seen on some non-myeloid cells *in vitro*.

The safety and efficacy of Ristempa have not been investigated in patients with myelodysplastic syndrome, chronic myelogenous leukaemia, and in patients with secondary Acute Myeloid Leukaemia (AML); therefore, it should not be used in such patients. Particular care should be taken to distinguish the diagnosis of blast transformation of chronic myeloid leukaemia from acute myeloid leukaemia.

The safety and efficacy of Ristempa administration in *de novo* AML patients aged < 55 years with cytogenetics t(15;17) have not been established.

The safety and efficacy of Ristempa have not been investigated in patients receiving high dose chemotherapy. This medicinal product should not be used to increase the dose of cytotoxic chemotherapy beyond established dosage regimens.

### Pulmonary adverse events

Uncommon ( $\geq 1/1,000$  to  $< 1/100$ ) pulmonary adverse reactions, in particular interstitial pneumonia, have been reported after G-CSF administration. Patients with a recent history of pulmonary infiltrates or pneumonia may be at higher risk (see section 4.8).

The onset of pulmonary signs such as cough, fever, and dyspnoea in association with radiological signs of pulmonary infiltrates, and deterioration in pulmonary function along with increased neutrophil count may be preliminary signs of Acute Respiratory Distress Syndrome (ARDS). In such circumstances Ristempa should be discontinued at the discretion of the physician and the appropriate treatment given (see section 4.8).

### Glomerulonephritis

Glomerulonephritis has been reported in patients receiving filgrastim and pegfilgrastim. Generally, events of glomerulonephritis resolved after dose reduction or withdrawal of filgrastim and pegfilgrastim. Urinalysis monitoring is recommended.

### Capillary leak syndrome

Capillary leak syndrome has been reported after granulocyte-colony stimulating factor administration and is characterised by hypotension, hypoalbuminaemia, oedema and hemoconcentration. Patients who develop symptoms of capillary leak syndrome should be closely monitored and receive standard symptomatic treatment, which may include a need for intensive care (see section 4.8).

### Splenomegaly and splenic rupture

Uncommon but generally asymptomatic cases of splenomegaly and uncommon cases of splenic rupture, including some fatal cases, have been reported following administration of pegfilgrastim (see section 4.8). Therefore, spleen size should be carefully monitored (e.g. clinical examination, ultrasound). A diagnosis of splenic rupture should be considered in patients reporting left upper abdominal pain or shoulder tip pain.

### Thrombocytopenia and anaemia

Treatment with Ristempa alone does not preclude thrombocytopenia and anaemia because full dose myelosuppressive chemotherapy is maintained on the prescribed schedule. Regular monitoring of platelet count and haematocrit is recommended. Special care should be taken when administering single or combination chemotherapeutic agents which are known to cause severe thrombocytopenia.

### Sickle cell anaemia

Sickle cell crises have been associated with the use of pegfilgrastim in patients with sickle cell trait or sickle cell disease (see section 4.8). Therefore, physicians should use caution when prescribing Ristempa in patients with sickle cell trait or sickle cell disease, should monitor appropriate clinical parameters and laboratory status and be attentive to the possible association of this medicine with splenic enlargement and vaso-occlusive crisis.

### Leukocytosis

White blood cell (WBC) counts of  $100 \times 10^9/l$  or greater have been observed in less than 1% of patients receiving Ristempa. No adverse events directly attributable to this degree of leukocytosis have been reported. Such elevation in white blood cells is transient, typically seen 24 to 48 hours after administration and is consistent with the pharmacodynamic effects of this medicine. Consistent with the clinical effects and the potential for leukocytosis, a WBC count should be performed at regular intervals during therapy. If leukocyte counts exceed  $50 \times 10^9/l$  after the expected nadir, this medicine should be discontinued immediately.

### Hypersensitivity

Hypersensitivity, including anaphylactic reactions, occurring on initial or subsequent treatment have been reported in patients treated with Ristempa. Permanently discontinue Ristempa in patients with clinically significant hypersensitivity. Do not administer Ristempa to patients with a history of hypersensitivity to pegfilgrastim or filgrastim. If a serious allergic reaction occurs, appropriate therapy should be administered, with close patient follow-up over several days.

## Immunogenicity

As with all therapeutic proteins, there is a potential for immunogenicity. Rates of generation of antibodies against pegfilgrastim is generally low. Binding antibodies do occur as expected with all biologics; however, they have not been associated with neutralising activity at present.

The safety and efficacy of Ristempa for the mobilisation of blood progenitor cells in patients or healthy donors has not been adequately evaluated.

The needle cap of the pre-filled syringe contains dry natural rubber (a derivative of latex), which may cause allergic reactions.

Increased haematopoietic activity of the bone marrow in response to growth factor therapy has been associated with transient positive bone imaging findings. This should be considered when interpreting bone-imaging results.

Ristempa contains sorbitol. Patients with rare hereditary problems of fructose intolerance should not take this medicine.

Ristempa contains less than 1 mmol (23 mg) sodium per 6 mg dose, i.e. essentially 'sodium-free'.

In order to improve the traceability of granulocyte-colony stimulating factors (G-CSFs), the trade name of the administered product should be clearly recorded in the patient file.

## **4.5 Interaction with other medicinal products and other forms of interaction**

Due to the potential sensitivity of rapidly dividing myeloid cells to cytotoxic chemotherapy, Ristempa should be administered at least 24 hours after administration of cytotoxic chemotherapy. In clinical trials, Ristempa has been safely administered 14 days before chemotherapy. Concomitant use of Ristempa with any chemotherapy agent has not been evaluated in patients. In animal models concomitant administration of Ristempa and 5-fluorouracil (5-FU) or other antimetabolites has been shown to potentiate myelosuppression.

Possible interactions with other haematopoietic growth factors and cytokines have not been specifically investigated in clinical trials.

The potential for interaction with lithium, which also promotes the release of neutrophils, has not been specifically investigated. There is no evidence that such an interaction would be harmful.

The safety and efficacy of Ristempa have not been evaluated in patients receiving chemotherapy associated with delayed myelosuppression e.g., nitrosoureas.

Specific interaction or metabolism studies have not been performed, however, clinical trials have not indicated an interaction of Ristempa with any other medicinal products.

## **4.6 Fertility, pregnancy and lactation**

### Pregnancy

There are no or limited amount of data from the use of pegfilgrastim in pregnant women. Studies in animals have shown reproductive toxicity (see section 5.3). Ristempa is not recommended during pregnancy and in women of childbearing potential not using contraception.

Women who become pregnant during Ristempa treatment are encouraged to enrol in Amgen's Pregnancy Surveillance Programme. Contact details are provided in section 6 of the Package leaflet.

## Breast-feeding

There is insufficient information on the excretion of Ristempa / metabolites in human milk, a risk to the newborns/infants cannot be excluded. A decision must be made whether to discontinue breast-feeding or to discontinue/abstain from Ristempa therapy taking into account the benefit of breast-feeding for the child and the benefit of therapy for the woman.

Women who are breast-feeding during Ristempa treatment are encouraged to enrol in Amgen's Lactation Surveillance programme. Contact details are provided in section 6 of the Package leaflet.

## Fertility

Pegfilgrastim did not affect reproductive performance or fertility in male or female rats at cumulative weekly doses approximately 6 to 9 times higher than the recommended human dose (based on body surface area) (see section 5.3).

### **4.7 Effects on ability to drive and use machines**

Ristempa has no or negligible influence on the ability to drive and use machines.

### **4.8 Undesirable effects**

#### Summary of the safety profile

The most frequently reported adverse reactions were bone pain (very common [ $\geq 1/10$ ]) and musculoskeletal pain (common). Bone pain was generally of mild to moderate severity, transient and could be controlled in most patients with standard analgesics.

Hypersensitivity-type reactions, including skin rash, urticaria, angioedema, dyspnoea, erythaema, flushing, and hypotension occurred on initial or subsequent treatment with Ristempa (uncommon [ $\geq 1/1,000$  to  $< 1/100$ ]). Serious allergic reactions, including anaphylaxis can occur in patients receiving Ristempa (uncommon) (see section 4.4).

Capillary Leak Syndrome, which can be life-threatening if treatment is delayed, has been reported as uncommon ( $\geq 1/1,000$  to  $< 1/100$ ) in cancer patients undergoing chemotherapy following administration of granulocyte colony-stimulating factors; see section 4.4 and section "Description of selected adverse reactions" below.

Splenomegaly, generally asymptomatic, is uncommon.

Splenic rupture including some fatal cases is uncommonly reported following administration of pegfilgrastim (see section 4.4).

Uncommon pulmonary adverse reactions including interstitial pneumonia, pulmonary oedema, pulmonary infiltrates and pulmonary fibrosis have been reported. Uncommonly, cases have resulted in respiratory failure or Acute Respiratory Distress Syndrome (ARDS), which may be fatal (see section 4.4).

Isolated cases of sickle cell crises have been reported in patients with sickle cell trait or sickle cell disease (uncommon in sickle cell patients) (see section 4.4).

Tabulated summary of adverse reactions

The data in the table below describe adverse reactions reported from clinical trials and spontaneous reporting. Within each frequency grouping, undesirable effects are presented in order of decreasing seriousness.

MedDRA system organ class	Adverse reactions				
	Very common (≥ 1/10)	Common (≥ 1/100 to < 1/10)	Uncommon (≥ 1/1,000 to < 1/100)	Rare (≥ 1/10,000 to < 1/1,000)	Very rare (< 1/10,000)
<b>Blood and lymphatic system disorders</b>		Thrombocytopenia <sup>1</sup> Leukocytosis <sup>1</sup>	Sickle cell crisis <sup>2</sup> ; Splenomegaly <sup>2</sup> ; Splenic rupture <sup>2</sup>		
<b>Immune system disorders</b>			Hypersensitivity reactions; Anaphylaxis		
<b>Metabolism and nutrition disorders</b>			Elevations in uric acid		
<b>Nervous system disorders</b>	Headache <sup>1</sup>				
<b>Vascular disorders</b>			Capillary leak syndrome		
<b>Respiratory, thoracic and mediastinal disorders</b>			Acute Respiratory Distress Syndrome <sup>2</sup> ; Pulmonary adverse reactions (interstitial pneumonia, pulmonary oedema, pulmonary infiltrates and pulmonary fibrosis)		
<b>Gastrointestinal disorders</b>	Nausea <sup>1</sup>				
<b>Skin and subcutaneous tissue disorders</b>			Sweet's syndrome (acute febrile dermatosis) <sup>1,2</sup> ; Cutaneous vasculitis <sup>1,2</sup>		
<b>Musculoskeletal and connective tissue disorders</b>	Bone pain	Musculoskeletal pain (myalgia, arthralgia, pain in extremity, back pain, musculoskeletal pain, neck pain)			
<b>General disorders and administrative site conditions</b>		Injection site pain <sup>1</sup> Non-cardiac chest pain	Injection site reactions <sup>2</sup>		
<b>Investigations</b>			Elevations in lactate dehydrogenase and alkaline phosphatase <sup>1</sup> ; Transient elevations in LFT's for ALT or AST <sup>1</sup>		

MedDRA system organ class	Adverse reactions				
	Very common (≥ 1/10)	Common (≥ 1/100 to < 1/10)	Uncommon (≥ 1/1,000 to < 1/100)	Rare (≥ 1/10,000 to < 1/1,000)	Very rare (< 1/10,000)
Renal and urinary disorders			Glomerulonephritis <sup>2</sup>		

<sup>1</sup> See section “Description of selected adverse reactions” below.

<sup>2</sup> This adverse reaction was identified through post-marketing surveillance but not observed in randomised, controlled clinical trials in adults. The frequency category was estimated from a statistical calculation based upon 1576 patients receiving Ristempa in nine randomized clinical trials.

#### Description of selected adverse reactions

Uncommon cases of Sweet’s syndrome have been reported, although in some cases underlying haematological malignancies may play a role.

Uncommon events of cutaneous vasculitis have been reported in patients treated with Ristempa. The mechanism of vasculitis in patients receiving Ristempa is unknown.

Injection site reactions, including injection site erythema (uncommon (≥ 1/1000 to < 1/100)) as well as injection site pain (common events ≥ 1/100 to < 1/10) have occurred on initial or subsequent treatment with Ristempa.

Common (≥ 1/100 to < 1/10) cases of leukocytosis (White Blood Count [WBC] > 100 x 10<sup>9</sup>/l) have been reported (see section 4.4).

Reversible, mild to moderate elevations in uric acid and alkaline phosphatase, with no associated clinical effects, were uncommon; reversible, mild to moderate elevations in lactate dehydrogenase, with no associated clinical effects, were uncommon in patients receiving Ristempa following cytotoxic chemotherapy.

Nausea and headaches were very commonly observed in patients receiving chemotherapy.

Uncommon elevations in liver function tests (LFTs) for ALT (alanine aminotransferase) or AST (aspartate aminotransferase), have been observed in patients after receiving pegfilgrastim following cytotoxic chemotherapy. These elevations are transient and return to baseline.

Common cases of thrombocytopenia have been reported.

Cases of capillary leak syndrome have been reported in the post marketing setting with granulocyte colony-stimulating factor use. These have generally occurred in patients with advanced malignant diseases, sepsis, taking multiple chemotherapy medications or undergoing apheresis (see section 4.4).

#### Paediatric population

The experience in children is limited. A higher frequency of serious adverse reactions in younger children aged 0-5 years (92%) has been observed compared to older children aged 6-11 and 12-21 years respectively (80% and 67%) and adults. The most common adverse reaction reported was bone pain (see section 5.1 and 5.2).

#### Reporting of suspected adverse reactions

Reporting suspected adverse reactions after authorisation of the medicinal product is important. It allows continued monitoring of the benefit/risk balance of the medicinal product. Healthcare



professionals are asked to report any suspected adverse reactions via the national reporting system listed in Appendix V.

#### 4.9 Overdose

Single doses of 300 µg/kg have been administered subcutaneously to a limited number of healthy volunteers and patients with non-small cell lung cancer without serious adverse reactions. The adverse events were similar to those in subjects receiving lower doses of pegfilgrastim.

### 5. PHARMACOLOGICAL PROPERTIES

#### 5.1 Pharmacodynamic properties

Pharmacotherapeutic group: immunostimulants, colony stimulating factor; ATC Code: L03AA13

Human granulocyte colony stimulating factor (G-CSF) is a glycoprotein, which regulates the production and release of neutrophils from the bone marrow. Pegfilgrastim is a covalent conjugate of recombinant human G-CSF (r-metHuG-CSF) with a single 20 kd polyethylene glycol (PEG) molecule. Pegfilgrastim is a sustained duration form of filgrastim due to decreased renal clearance.

Pegfilgrastim and filgrastim have been shown to have identical modes of action, causing a marked increase in peripheral blood neutrophil counts within 24 hours, with minor increases in monocytes and/or lymphocytes. Similarly to filgrastim, neutrophils produced in response to pegfilgrastim show normal or enhanced function as demonstrated by tests of chemotactic and phagocytic function. As with other haematopoietic growth factors, G-CSF has shown *in vitro* stimulating properties on human endothelial cells. G-CSF can promote growth of myeloid cells, including malignant cells, *in vitro* and similar effects may be seen on some non-myeloid cells *in vitro*.

In two randomised, double-blind, pivotal studies in patients with high risk stage II-IV breast cancer undergoing myelosuppressive chemotherapy consisting of doxorubicin and docetaxel, use of pegfilgrastim, as a single once per cycle dose, reduced the duration of neutropenia and the incidence of febrile neutropenia similarly to that observed with daily administrations of filgrastim (a median of 11 daily administrations). In the absence of growth factor support, this regimen has been reported to result in a mean duration of grade 4 neutropenia of 5 to 7 days, and a 30-40% incidence of febrile neutropenia. In one study (n = 157), which used a 6mg fixed dose of pegfilgrastim the mean duration of grade 4 neutropenia for the pegfilgrastim group was 1.8 days compared with 1.6 days in the filgrastim group (difference 0.23 days, 95% CI -0.15, 0.63). Over the entire study, the rate of febrile neutropenia was 13% of pegfilgrastim-treated patients compared with 20% of filgrastim-treated patients (difference 7%, 95% CI of -19%, 5%). In a second study (n = 310), which used a weight-adjusted dose (100 µg/kg), the mean duration of grade 4 neutropenia for the pegfilgrastim group was 1.7 days, compared with 1.8 days in the filgrastim group (difference 0.03 days, 95% CI -0.36, 0.30). The overall rate of febrile neutropenia was 9% of patients treated with pegfilgrastim and 18% of patients treated with filgrastim (difference 9%, 95% CI of -16.8%, -1.1%).

In a placebo-controlled, double blind study in patients with breast cancer the effect of pegfilgrastim on the incidence of febrile neutropenia was evaluated following administration of a chemotherapy regimen associated with a febrile neutropenia rate of 10-20% (docetaxel 100 mg/m<sup>2</sup> every 3 weeks for 4 cycles). Nine hundred and twenty eight patients were randomised to receive either a single dose of pegfilgrastim or placebo approximately 24 hours (Day 2) after chemotherapy in each cycle. The incidence of febrile neutropenia was lower for patients randomised to receive pegfilgrastim compared with placebo (1% versus 17%, p < 0.001). The incidence of hospitalisations and IV anti-infective use associated with a clinical diagnosis of febrile neutropenia was lower in the pegfilgrastim group compared with placebo (1% versus 14%, p < 0.001; and 2% versus 10%, p < 0.001).

A small (n = 83), Phase II, randomised, double-blind study in patients receiving chemotherapy for *de novo* acute myeloid leukaemia compared pegfilgrastim (single dose of 6 mg) with filgrastim,

administered during induction chemotherapy. Median time to recovery from severe neutropenia was estimated as 22 days in both treatment groups. Long term outcome was not studied (see section 4.4).

In a phase II (n = 37) multicentre, randomised, open-label study of paediatric sarcoma patients receiving 100 µg/kg pegfilgrastim following cycle 1 of vincristine, doxorubicin and cyclophosphamide (VAdriaC/IE) chemotherapy, a longer duration of severe neutropenia (neutrophils < 0.5 x 10<sup>9</sup>) was observed in younger children aged 0-5 yrs (8.9 days) compared to older children aged 6-11 years and 12-21 years (6 days and 3.7 days, respectively) and adults. Additionally a higher incidence of febrile neutropenia was observed in younger children aged 0-5 yrs (75%) compared to older children aged 6-11 years and 12-21 years (70% and 33%, respectively) and adults (see sections 4.8 and 5.2).

## 5.2 Pharmacokinetic properties

After a single subcutaneous dose of pegfilgrastim, the peak serum concentration of pegfilgrastim occurs at 16 to 120 hours after dosing and serum concentrations of pegfilgrastim are maintained during the period of neutropenia after myelosuppressive chemotherapy. The elimination of pegfilgrastim is non-linear with respect to dose; serum clearance of pegfilgrastim decreases with increasing dose. Pegfilgrastim appears to be mainly eliminated by neutrophil mediated clearance, which becomes saturated at higher doses. Consistent with a self-regulating clearance mechanism, the serum concentration of pegfilgrastim declines rapidly at the onset of neutrophil recovery (see figure 1).

**Figure 1. Profile of Median Pegfilgrastim Serum Concentration and Absolute Neutrophil Count (ANC) in Chemotherapy Treated Patients after a Single 6 mg Injection**

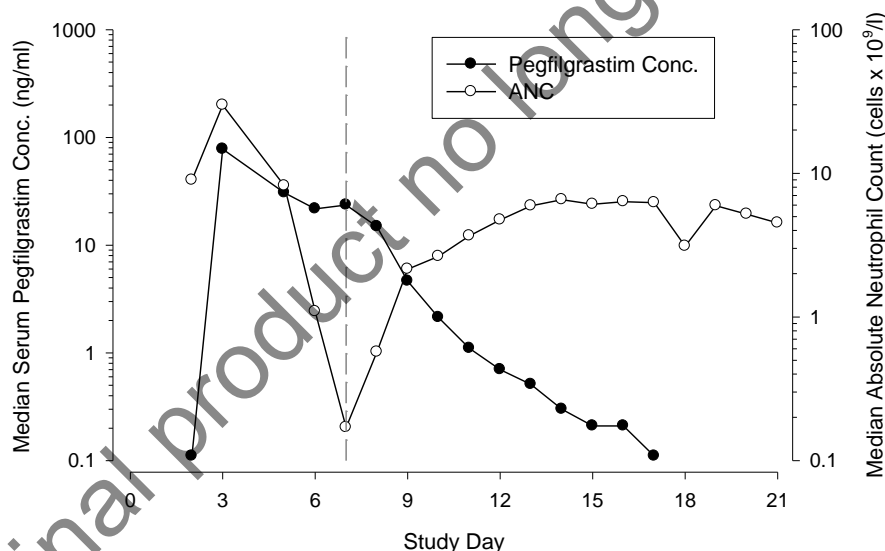

Due to the neutrophil-mediated clearance mechanism, the pharmacokinetics of pegfilgrastim is not expected to be affected by renal or hepatic impairment. In an open label, single dose study (n = 31) various stages of renal impairment, including end-stage renal disease, had no impact on the pharmacokinetics of pegfilgrastim.

### Elderly people

Limited data indicate that the pharmacokinetics of pegfilgrastim in elderly subjects (> 65 years) is similar to that in adults.

## Paediatric population

The pharmacokinetics of pegfilgrastim were studied in 37 paediatric patients with sarcoma, who received 100 µg/kg pegfilgrastim after the completion of VAdriaC/IE chemotherapy. The youngest age group (0-5 years) had a higher mean exposure to pegfilgrastim (AUC) ( $\pm$  Standard Deviation) ( $47.9 \pm 22.5$  µg·hr/ml) than older children aged 6-11 years and 12-21 years ( $22.0 \pm 13.1$  µg·hr/ml and  $29.3 \pm 23.2$  µg·hr/ml, respectively) (see section 5.1). With the exception of the youngest age group (0-5 years), the mean AUC in paediatric subjects appeared similar to that for adult patients with high-risk stage II-IV breast cancer and receiving 100 µg/kg pegfilgrastim after the completion of doxorubicin/docetaxel (see sections 4.8 and 5.1).

### **5.3 Preclinical safety data**

Preclinical data from conventional studies of repeated dose toxicity revealed the expected pharmacological effects including increases in leukocyte count, myeloid hyperplasia in bone marrow, extramedullary haematopoiesis and splenic enlargement.

There were no adverse effects observed in offspring from pregnant rats given pegfilgrastim subcutaneously, but in rabbits pegfilgrastim has been shown to cause embryo/foetal toxicity (embryo loss) at cumulative doses approximately 4 times the recommended human dose, which were not seen when pregnant rabbits were exposed to the recommended human dose. In rat studies, it was shown that pegfilgrastim may cross the placenta. Studies in rats indicated that reproductive performance, fertility, oestrous cycling, days between pairing and coitus, and intrauterine survival were unaffected by pegfilgrastim given subcutaneously. The relevance of these findings for humans is not known.

## **6. PHARMACEUTICAL PARTICULARS**

### **6.1 List of excipients**

Sodium acetate\*  
Sorbitol (E420)  
Polysorbate 20  
Water for injections

\*Sodium acetate is formed by titrating glacial acetic acid with sodium hydroxide.

### **6.2 Incompatibilities**

This medicinal product must not be mixed with other medicinal products, particularly with sodium chloride solutions.

### **6.3 Shelf life**

3 years.

### **6.4 Special precautions for storage**

Store in a refrigerator (2°C – 8°C).

Ristempa may be exposed to room temperature (not above 30°C) for a maximum single period of up to 72 hours. Ristempa left at room temperature for more than 72 hours should be discarded.

Do not freeze. Accidental exposure to freezing temperatures for a single period of less than 24 hours does not adversely affect the stability of Ristempa.

Keep the container in the outer carton in order to protect from light.

## **6.5 Nature and contents of container**

Pre-filled syringe (Type I glass), with a rubber stopper and a stainless steel needle with or without an automatic needle guard.

The needle cap of the pre-filled syringe contains dry natural rubber (a derivative of latex) (see section 4.4).

Each pre-filled syringe contains 0.6 ml of solution for injection. Pack size of one pre-filled syringe, in either a blistered or non-blistered packaging.

Not all pack sizes may be marketed.

## **6.6 Special precautions for disposal and other handling**

Before administration, Ristempa solution should be inspected visually for particulate matter. Only a solution that is clear and colourless should be injected.

Excessive shaking may aggregate pegfilgrastim, rendering it biologically inactive.

Allow the pre-filled syringe to reach room temperature before injecting.

Any unused product or waste material should be disposed of in accordance with local requirements.

## **7. MARKETING AUTHORISATION HOLDER**

Amgen Europe B.V.  
Minervum 7061  
4817 ZK Breda  
The Netherlands

## **8. MARKETING AUTHORISATION NUMBER(S)**

EU/1/15/996/001 1 pack blistered syringe  
EU/1/15/996/002 1 pack unblistered syringe  
EU/1/15/996/003 1 pack blistered syringe with needle guard

## **9. DATE OF FIRST AUTHORISATION/RENEWAL OF THE AUTHORISATION**

Date of first authorisation: April 2015

## **10. DATE OF REVISION OF THE TEXT**

Detailed information on this medicinal product is available on the website of the European Medicines Agency <http://www.ema.europa.eu>

**ANNEX II**

- A. MANUFACTURER(S) OF THE BIOLOGICAL ACTIVE SUBSTANCE AND MANUFACTURER(S) RESPONSIBLE FOR BATCH RELEASE**
- B. CONDITIONS OR RESTRICTIONS REGARDING SUPPLY AND USE**
- C. OTHER CONDITIONS AND REQUIREMENTS OF THE MARKETING AUTHORISATION**
- D. CONDITIONS OR RESTRICTIONS WITH REGARD TO THE SAFE AND EFFECTIVE USE OF THE MEDICINAL PRODUCT**

**A. MANUFACTURER(S) OF THE BIOLOGICAL ACTIVE SUBSTANCE AND  
MANUFACTURER(S) RESPONSIBLE FOR BATCH RELEASE**

Name and address of the manufacturers of the biological active substance

Amgen Inc.  
One Amgen Center Drive  
Thousand Oaks  
CA 91320  
USA

Amgen Manufacturing Limited  
P.O Box 4060  
Road 31 km. 24.6  
Juncos  
Puerto Rico 00777-4060  
USA

Name and address of the manufacturers responsible for batch release

Amgen Europe BV  
Minervum 7061  
NL-4817 ZK Breda  
The Netherlands

Amgen Technology (Ireland) Unlimited Company  
Pottery Road  
Dun Laoghaire  
Co Dublin  
Ireland

The printed package leaflet of the medicinal product must state the name and address of the manufacturer responsible for the release of the concerned batch.

**B. CONDITIONS OR RESTRICTIONS REGARDING SUPPLY AND USE**

Medicinal product subject to restricted medical prescription (See Annex I: Summary of Product Characteristics, 4.2).

**C. OTHER CONDITIONS AND REQUIREMENTS OF THE MARKETING  
AUTHORISATION**

• **Periodic Safety Update Reports**

The marketing authorisation holder shall submit periodic safety update reports for this product in accordance with the requirements set out in the list of Union reference dates (EURD list) ) provided for under Article 107c(7) of Directive 2001/83/EC and published on the European medicines web-portal.

**D. CONDITIONS OR RESTRICTIONS WITH REGARD TO THE SAFE AND EFFECTIVE USE OF THE MEDICINAL PRODUCT**

- **Risk Management Plan (RMP)**

The MAH shall perform the required pharmacovigilance activities and interventions detailed in the agreed RMP presented in Module 1.8.2 of the Marketing Authorisation and any agreed subsequent updates of the RMP.

An updated RMP should be submitted:

- At the request of the European Medicines Agency;
- Whenever the risk management system is modified, especially as the result of new information being received that may lead to a significant change to the benefit/risk profile or as the result of an important (pharmacovigilance or risk minimisation) milestone being reached.

If the dates for submission of a PSUR and the update of a RMP coincide, they can be submitted at the same time.

Medicinal product no longer authorised

Medicinal product no longer authorised

**ANNEX III**  
**LABELLING AND PACKAGE LEAFLET**



**A. LABELLING**

Medicinal product no longer authorised

**PARTICULARS TO APPEAR ON THE OUTER PACKAGING**

**OUTER CARTON FOR BLISTERED SYRINGE**

**1. NAME OF THE MEDICINAL PRODUCT**

Ristempa 6 mg solution for injection  
Pegfilgrastim

**2. STATEMENT OF ACTIVE SUBSTANCE(S)**

Each pre-filled syringe contains 6 mg of pegfilgrastim in 0.6 ml (10 mg/ml) solution for injection.

**3. LIST OF EXCIPIENTS**

Excipients: sodium acetate, sorbitol (E420), polysorbate 20, water for injections. See leaflet for further information.

**4. PHARMACEUTICAL FORM AND CONTENTS**

Solution for injection in a single use pre-filled syringe (0.6 ml).  
Solution for injection in a single use pre-filled syringe with automatic needle guard (0.6 ml).  
Pack size of one.

**5. METHOD AND ROUTE(S) OF ADMINISTRATION**

For subcutaneous use.  
Read the package leaflet before use.  
**Important:** read the package leaflet before handling pre-filled syringe.

**6. SPECIAL WARNING THAT THE MEDICINAL PRODUCT MUST BE STORED OUT OF THE SIGHT AND REACH OF CHILDREN**

Keep out of the sight and reach of children.

**7. OTHER SPECIAL WARNING(S), IF NECESSARY**

**Avoid vigorous shaking.**

**8. EXPIRY DATE**

EXP

**9. SPECIAL STORAGE CONDITIONS**

Store in a refrigerator.

Do not freeze.

Keep the container in the outer carton in order to protect from light.

**10. SPECIAL PRECAUTIONS FOR DISPOSAL OF UNUSED MEDICINAL PRODUCTS OR WASTE MATERIALS DERIVED FROM SUCH MEDICINAL PRODUCTS, IF APPROPRIATE**

**11. NAME AND ADDRESS OF THE MARKETING AUTHORISATION HOLDER**

Amgen Europe B.V.  
Minervum 7061  
4817 ZK Breda  
The Netherlands

**12. MARKETING AUTHORISATION NUMBER(S)**

EU/1/15/996/001 1 pack

EU/1/15/996/003 1 pack with needle guard

**13. BATCH NUMBER**

Lot

**14. GENERAL CLASSIFICATION FOR SUPPLY**

Medicinal product subject to medical prescription.

**15. INSTRUCTIONS ON USE**

**16. INFORMATION IN BRAILLE**

Ristempa

**MINIMUM PARTICULARS TO APPEAR ON BLISTERS OR STRIPS**

**BLISTER PACK WITH SYRINGE**

**1. NAME OF THE MEDICINAL PRODUCT**

Ristempa 6 mg injection  
Pegfilgrastim

**2. NAME OF THE MARKETING AUTHORISATION HOLDER**

Amgen Europe B.V.

**3. EXPIRY DATE**

EXP

**4. BATCH NUMBER**

Lot

**5. OTHER**

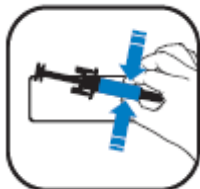

Medicinal product no longer authorised

**MINIMUM PARTICULARS TO APPEAR ON SMALL IMMEDIATE PACKAGING UNITS**

**BLISTERED SYRINGE LABEL**

**1. NAME OF THE MEDICINAL PRODUCT AND ROUTE(S) OF ADMINISTRATION**

Ristempa 6 mg  
Pegfilgrastim  
SC

**2. METHOD OF ADMINISTRATION**

**3. EXPIRY DATE**

EXP

**4. BATCH NUMBER**

Lot

**5. CONTENTS BY WEIGHT, BY VOLUME OR BY UNIT**

0.6 ml

**6. OTHER**

Amgen Europe B.V.

Medicinal product no longer authorised

**PARTICULARS TO APPEAR ON THE OUTER PACKAGING**

**OUTER CARTON FOR UNBLISTERED SYRINGE**

**1. NAME OF THE MEDICINAL PRODUCT**

Ristempa 6 mg solution for injection  
Pegfilgrastim

**2. STATEMENT OF ACTIVE SUBSTANCE(S)**

Each pre-filled syringe contains 6 mg of pegfilgrastim in 0.6 ml (10 mg/ml) solution for injection.

**3. LIST OF EXCIPIENTS**

Excipients: sodium acetate, sorbitol (E420), polysorbate 20, water for injections. See leaflet for further information.

**4. PHARMACEUTICAL FORM AND CONTENTS**

Solution for injection in a single use pre-filled syringe (0.6 ml).  
Pack size of one.

**5. METHOD AND ROUTE(S) OF ADMINISTRATION**

For subcutaneous use.  
Read the package leaflet before use.

**6. SPECIAL WARNING THAT THE MEDICINAL PRODUCT MUST BE STORED OUT OF THE SIGHT AND REACH OF CHILDREN**

Keep out of the sight and reach of children.

**7. OTHER SPECIAL WARNING(S), IF NECESSARY**

**Avoid vigorous shaking.**

**8. EXPIRY DATE**

EXP

**9. SPECIAL STORAGE CONDITIONS**

Store in a refrigerator.  
Do not freeze.  
Keep the container in the outer carton in order to protect from light.

**10. SPECIAL PRECAUTIONS FOR DISPOSAL OF UNUSED MEDICINAL PRODUCTS OR WASTE MATERIALS DERIVED FROM SUCH MEDICINAL PRODUCTS, IF APPROPRIATE**

**11. NAME AND ADDRESS OF THE MARKETING AUTHORISATION HOLDER**

Amgen Europe B.V.  
Minervum 7061  
4817 ZK Breda  
The Netherlands

**12. MARKETING AUTHORISATION NUMBER(S)**

EU/1/15/996/002

**13. BATCH NUMBER**

Lot

**14. GENERAL CLASSIFICATION FOR SUPPLY**

Medicinal product subject to medical prescription.

**15. INSTRUCTIONS ON USE**

**16. INFORMATION IN BRAILLE**

Ristempa

Medicinal product no longer authorised

**MINIMUM PARTICULARS TO APPEAR ON SMALL IMMEDIATE PACKAGING UNITS  
UNBLISTERED SYRINGE LABEL**

**1. NAME OF THE MEDICINAL PRODUCT AND ROUTE(S) OF ADMINISTRATION**

Ristempa 6 mg injection  
Pegfilgrastim  
SC

**2. METHOD OF ADMINISTRATION**

**3. EXPIRY DATE**

EXP

**4. BATCH NUMBER**

Lot

**5. CONTENTS BY WEIGHT, BY VOLUME OR BY UNIT**

0.6 ml

**6. OTHER**

Amgen Europe B.V.

Medicinal product no longer authorised



Medicinal product no longer authorised

**B. PACKAGE LEAFLET**

## Package leaflet: Information for the user

### Ristempa 6 mg solution for injection in a pre-filled syringe pegfilgrastim

▼ This medicine is subject to additional monitoring. This will allow quick identification of new safety information. You can help by reporting any side effects you may get. See the end of section 4 for how to report side effects.

#### **Read all of this leaflet carefully before you start using this medicine because it contains important information for you.**

- Keep this leaflet. You may need to read it again.
- If you have any further questions, ask your doctor, pharmacist or nurse.
- This medicine has been prescribed for you only. Do not pass it on to others. It may harm them, even if their symptoms of illness are the same as yours.
- If you get any side effects, talk to your doctor, pharmacist or nurse. This includes any possible side effects not listed in this leaflet. See section 4.

#### **What is in this leaflet**

1. What Ristempa is and what it is used for
2. What you need to know before you use Ristempa
3. How to use Ristempa
4. Possible side effects
5. How to store Ristempa
6. Contents of the pack and other information

#### **1. What Ristempa is and what it is used for**

Ristempa contains the active substance pegfilgrastim. Pegfilgrastim is a protein produced by biotechnology in bacteria called *E. coli*. It belongs to a group of proteins called cytokines, and is very similar to a natural protein (granulocyte-colony stimulating factor) produced by your own body.

Ristempa is used to reduce the duration of neutropenia (low white blood cell count) and the occurrence of febrile neutropenia (low white blood cell count with a fever) which can be caused by the use of cytotoxic chemotherapy (medicines that destroy rapidly growing cells). White blood cells are important as they help your body fight infection. These cells are very sensitive to the effects of chemotherapy which can cause the number of these cells in your body to decrease. If white blood cells fall to a low level there may not be enough left in the body to fight bacteria and you may have an increased risk of infection.

Your doctor has given you Ristempa to encourage your bone marrow (part of the bone which makes blood cells) to produce more white blood cells that help your body fight infection.

#### **2. What you need to know before you use Ristempa**

##### **Do not use Ristempa**

- if you are allergic to pegfilgrastim, filgrastim, *E. coli* derived proteins, or any of the other ingredients of this medicine.

## Warnings and precautions

Talk to your doctor, pharmacist or nurse before using Ristempa:

- if you experience an allergic reaction including weakness, drop in blood pressure, difficulty breathing, swelling of the face (anaphylaxis), redness and flushing, skin rash and areas of the skin that itch
- have an allergy to latex. The needle cap on the pre-filled syringe contains a derivative of latex and may cause severe allergic reactions
- experience a cough, fever and difficulty breathing. This can be a sign of Acute Respiratory Distress Syndrome (ARDS)
- if you have any of the following or combination of the following side effects:
  - swelling or puffiness, which may be associated with passing water less frequently, difficulty breathing, abdominal swelling and feeling of fullness, and a general feeling of tirednessThese could be symptoms of condition called “Capillary Leak Syndrome” which causes blood to leak from the small blood vessels into your body. See section 4.
- get left upper abdominal pain or pain at the tip of your shoulder. This may be a sign of a problem with your spleen (splenomegaly)
- have recently had a serious lung infection (pneumonia), fluid in the lungs (pulmonary oedema), inflammation of the lungs (interstitial lung disease) or an abnormal chest x-ray (lung infiltration)
- are aware of any altered blood cell counts (e.g. increase in white blood cells or anaemia) or decreased blood platelet counts, which reduces the ability of your blood to clot (thrombocytopenia). Your doctor may want to monitor you more closely
- have sickle cell anaemia. Your doctor may monitor your condition more closely.
- if you have sudden signs of allergy such as rash, itching or hives on the skin, swelling of the face, lips, tongue or other parts of the body, shortness of breath, wheezing or trouble breathing these could be signs of a severe allergic reaction.

Your doctor will check your blood and urine regularly as Ristempa can harm the tiny filters inside your kidneys (glomerulonephritis).

You should talk to your doctor about your risks of developing cancers of the blood. If you develop or are likely to develop cancers of the blood, you should not use Ristempa, unless instructed by your doctor.

### Loss of response to pegfilgrastim

If you experience a loss of response or failure to maintain a response with pegfilgrastim treatment, your doctor will investigate the reasons why including whether you have developed antibodies which neutralise pegfilgrastim’s activity.

### Other medicines and Ristempa

Tell your doctor or pharmacist if you are taking, have recently taken or might take any other medicines.

### Pregnancy and breast-feeding

Ask your doctor or pharmacist for advice before taking any medicine. Ristempa has not been tested in pregnant women. It is important to tell your doctor if you:

- are pregnant;
- think you may be pregnant; or
- are planning to have a baby.

If you become pregnant during Ristempa treatment, please inform your doctor. You may be encouraged to enrol in Amgen's Pregnancy Surveillance programme. Local representative contact details are provided in section 6 of this leaflet.

Unless your doctor directs you otherwise, you must stop breast feeding if you use Ristempa.

If you are nursing during Ristempa treatment, you may be encouraged to enrol in Amgen's Lactation Surveillance programme. Local representative contact details are provided in section 6 of this leaflet.

### **Driving and using machines**

Ristempa has no or negligible effect on the ability to drive or use machines.

### **Ristempa contains sorbitol (E420) and sodium acetate**

Ristempa contains sorbitol (a type of sugar). If you have been told by your doctor that you have an intolerance to some sugars, contact your doctor before taking this medicinal product.

This medicinal product contains less than 1 mmol (23 mg) sodium per 6 mg dose, i.e. essentially 'sodium-free'

## **3. How to use Ristempa**

Ristempa is for use in adults aged 18 and over.

Always take Ristempa exactly as your doctor has told you. You should check with your doctor or pharmacist if you are unsure. The usual dose is one 6 mg subcutaneous injection (injection under your skin) using a pre-filled syringe and it should be given at least 24 hours after your last dose of chemotherapy at the end of each chemotherapy cycle.

Do not shake Ristempa vigorously as this may affect its activity.

### **Injecting Ristempa yourself**

Your doctor may decide that it would be more convenient for you to inject Ristempa yourself. Your doctor or nurse will show you how to inject yourself. Do not try to inject yourself if you have not been trained.

For further instructions on how to inject yourself with Ristempa, please read the section at the end of this leaflet.

### **If you use more Ristempa than you should**

If you use more Ristempa than you should contact your doctor, pharmacist or nurse.

### **If you forget to inject Ristempa**

If you have forgotten a dose of Ristempa, you should contact your doctor to discuss when you should inject the next dose

If you have any further questions on the use of this medicine, ask your doctor, pharmacist or nurse.

## **4. Possible side effects**

Like all medicines, this medicine can cause side effects, although not everybody gets them.

Please tell your doctor immediately if you have any of the following or combination of the following side effects:

- swelling or puffiness, which may be associated with passing water less frequently, difficulty breathing, abdominal swelling and feeling of fullness, and a general feeling of tiredness. These symptoms generally develop in a rapid fashion.

These could be symptoms of an uncommon (may affect up to 1 in 100 people) condition called “Capillary Leak Syndrome” which causes blood to leak from the small blood vessels into your body and needs urgent medical attention.

**Very common side effects** (may affect more than 1 in 10 people):

- bone pain. Your doctor will tell you what you can take to ease the bone pain.
- nausea and headaches.

**Common side effects** (may affect up to 1 in 10 people):

- pain at the site of injection.
- general aches and pains in the joints and muscles.
- some changes may occur in your blood, but these will be detected by routine blood tests. Your white blood cell count may become high for a short period of time. Your platelet count may become low which might result in bruising.

**Uncommon side effects** (may affect up to 1 in 100 people):

- allergic-type reactions, including redness and flushing, skin rash, and raised areas of the skin that itch.
- serious allergic reactions, including anaphylaxis (weakness, drop in blood pressure, difficulty breathing, swelling of the face).
- increased spleen size.
- spleen rupture. Some cases of splenic rupture were fatal. It is important that you contact your doctor immediately if you experience pain in the upper left side of the abdomen or left shoulder pain since this may relate to a problem with your spleen.
- breathing problems. If you have a cough, fever and difficulty breathing please tell your doctor.
- Sweet’s syndrome (plum-coloured, raised, painful lesions on the limbs and sometimes the face and neck with fever) has occurred but other factors may play a role.
- cutaneous vasculitis (inflammation of the blood vessels in the skin).
- damage to the tiny filters inside your kidneys (glomerulonephritis).
- redness at the site of injection.

### **Reporting of side effects**

If you get any side effects, talk to your doctor, pharmacist or nurse. This includes any possible side effects not listed in this leaflet. You can also report side effects directly via the **national reporting system** listed in Appendix V. By reporting side effects you can help provide more information on the safety of this medicine.

## **5. How to store Ristempa**

Keep this medicine out of the sight and reach of children.

Do not use this medicine after the expiry date which is stated on the carton and on the syringe label after EXP. The expiry date refers to the last day of that month.

Store in a refrigerator (2°C – 8°C).

You may take Ristempa out of the refrigerator and keep it at room temperature (not above 30°C) for no longer than 3 days. Once a syringe has been removed from the refrigerator and has reached room temperature (not above 30°C) it must either be used within 3 days or disposed of.

Do not freeze. Ristempa may be used if it is accidentally frozen for a single period of less than 24 hours.

Keep the container in the outer carton in order to protect from light.

Do not use this medicine if you notice it is cloudy or there are particles in it.

Do not throw away any medicines via wastewater or household waste. Ask your pharmacist how to throw away medicines you no longer use. These measures will help to protect the environment.

## **6. Contents of the pack and other information**

### **What Ristempa contains**

- The active substance is pegfilgrastim. Each pre-filled syringe contains 6 mg of pegfilgrastim in 0.6 ml of solution.
- The other ingredients are sodium acetate, sorbitol (E420), polysorbate 20 and water for injections. See section 2.

### **What Ristempa looks like and contents of the pack**

Ristempa is a clear, colourless solution for injection in a pre-filled syringe (6 mg/0.6 ml).

Each pack contains 1 pre-filled syringe of type I glass with an attached stainless steel needle and needle cap. The syringes are provided either with or without a blister wrapping.

### **Marketing Authorisation Holder and Manufacturer:**

Amgen Europe B.V.  
Minervum 7061  
4817 ZK Breda  
The Netherlands

### **Marketing Authorisation Holder:**

Amgen Europe B.V.  
Minervum 7061  
4817 ZK Breda  
The Netherlands

### **Manufacturer:**

Amgen Technology (Ireland) Unlimited Company  
Pottery Road  
Dun Laoghaire  
Co Dublin  
Ireland

For any information about this medicine, please contact the local representative of the Marketing Authorisation Holder.

### **België/Belgique/Belgien**

s.a. Amgen n.v.  
Tel/Tél: +32 (0)2 7752711

### **Lietuva**

Amgen Switzerland AG Vilniaus filialas  
Tel: +370 5 219 7474

**България**

Амджен България ЕООД  
Тел.: +359 (0)2 424 7440

**Česká republika**

Amgen s.r.o.  
Tel: +420 221 773 500

**Danmark**

Amgen filial af Amgen AB, Sverige  
Tlf: +45 39617500

**Deutschland**

AMGEN GmbH  
Tel.: +49 89 1490960

**Eesti**

Amgen Switzerland AG Vilniaus filialas  
Tel: +372 5125 501

**Ελλάδα**

Amgen Ελλάς Φαρμακευτικά Ε.Π.Ε.  
Τηλ.: +30 210 3447000

**España**

Amgen S.A.  
Tel: +34 93 600 18 60

**France**

Amgen S.A.S.  
Tél: +33 (0)9 69 363 363

**Hrvatska**

Amgen d.o.o.  
Tel: +385 (1) 562 57 20

**Ireland**

Amgen Limited  
United Kingdom  
Tel: +44 (0)1223 420305

**Ísland**

Vistor hf.  
Sími: +354 535 7000

**Italia**

Amgen S.r.l.  
Tel: +39 02 6241121

**Κύπρος**

Papaellinas & Co Ltd  
Τηλ.: +357 22741 741

**Luxembourg/Luxemburg**

s.a. Amgen  
Belgique/Belgien  
Tel/Tél: +32 (0)2 7752711

**Magyarország**

Amgen Kft.  
Tel.: +36 1 35 44 700

**Malta**

Amgen B.V.  
The Netherlands  
Tel: +31 (0)76 5732500

**Nederland**

Amgen B.V.  
Tel: +31 (0)76 5732500

**Norge**

Amgen AB  
Tel: +47 23308000

**Österreich**

Amgen GmbH  
Tel: +43 (0)1 50 217

**Polska**

Amgen Biotechnologia Sp. z o.o.  
Tel.: +48 22 581 3000

**Portugal**

Amgen Biofarmacêutica, Lda.  
Tel: +351 21 4220550

**România**

Amgen România SRL  
Tel: +4021 527 3000

**Slovenija**

AMGEN zdravila d.o.o.  
Tel: +386 (0)1 585 1767

**Slovenská republika**

Amgen Slovakia s.r.o.  
Tel: +421 33 321 13 22

**Suomi/Finland**

Amgen AB, sivuliike Suomessa/Amgen AB, filial  
i Finland  
Puh/Tel: +358 (0)9 54900500

**Sverige**

Amgen AB  
Tel: +46 (0)8 6951100

**Latvija**  
Amgen Switzerland AG Rīgas filiāle  
Tel: +371 292 84807

**United Kingdom**  
Amgen Limited  
Tel: +44 (0)1223 420305

**This leaflet was last revised in**

**Other sources of information**

Detailed information on this medicine is available on the European Medicines Agency web site:  
<http://www.ema.europa.eu>

---

### **Instructions for injecting with the Ristempa pre-filled syringe**

This section contains information on how to give yourself an injection of Ristempa. It is important that you do not try to give yourself the injection unless you have received training from your doctor, nurse, or pharmacist. If you have questions about how to inject, please ask your doctor, nurse, pharmacist for assistance.

#### **How do you, or the person injecting you, use Ristempa pre-filled syringe?**

You will need to give yourself the injection into the tissue just under the skin. This is known as a subcutaneous injection.

#### **Equipment that you need**

To give yourself a subcutaneous injection you will need:

- a pre-filled syringe of Ristempa; and
- alcohol wipes or similar.

#### **What should I do before I give myself a subcutaneous injection of Ristempa?**

1. Remove from the refrigerator.
2. Do not shake the pre-filled syringe.
3. **Do not** remove the cap from the syringe until you are ready to inject.
4. Check the expiry date on the pre-filled syringe label (EXP). Do not use it if the date has passed the last day of the month shown.
5. Check the appearance of Ristempa. It must be a clear and colourless liquid. If there are particles in it, you must not use it.
6. For a more comfortable injection, let the pre-filled syringe stand for 30 minutes to reach room temperature or hold the pre-filled syringe gently in your hand for a few minutes. **Do not** warm Ristempa in any other way (for example, do not warm it in a microwave or in hot water).
7. **Wash your hands thoroughly.**
8. Find a comfortable, well-lit, clean surface and put all the equipment you need within reach.



## How do I prepare my Ristempa injection?

Before you inject Ristempa you must do the following:

1. Hold the syringe barrel and gently take the cap from the needle without twisting. Pull straight as shown in pictures 1 and 2. Do not touch the needle or push the plunger.

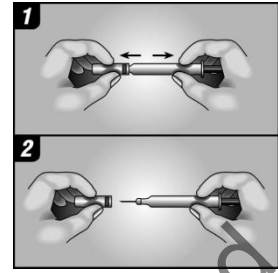

2. You may notice a small air bubble in the pre-filled syringe. You do not have to remove the air bubble before injecting. Injecting the solution with the air bubble is harmless.
3. You can now use the pre-filled syringe.

## Where should I give my injection?

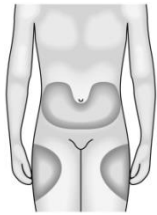

The most suitable places to inject yourself are:

- the top of your thighs; and
- the abdomen, except for the area around the navel.

If someone else is injecting you, they can also use the back of your arms.

## How do I give my injection?

1. Clean your skin by using an alcohol wipe.
2. Pinch (without squeezing) the skin using your thumb and forefinger. Insert the needle into the skin.
3. Push the plunger down with a slow constant pressure. Push the plunger all the way down as far as it will go to inject all the liquid.
4. After injecting the liquid, remove the needle and let go of your skin.
5. If you notice a spot of blood at the injection site dab with a cotton ball or tissues. Do not rub the injection site. If needed, you may cover the injection site with a plaster.
6. Do not use any Ristempa that is left in the syringe.

## Remember

Only use each syringe for one injection. If you have any problems, please ask your doctor or nurse for help and advice.

## Disposing of used syringes

- Do not put the cap back on used needles.
- Keep used syringes out of the sight and reach of children.

- The used syringe should be disposed of in accordance with local requirements. Ask your pharmacist how to dispose of medicines no longer required. These measures will help to protect the environment.

Medicinal product no longer authorised

## Package leaflet: Information for the user

### Ristempa 6 mg solution for injection in a pre-filled syringe pegfilgrastim

▼ This medicine is subject to additional monitoring. This will allow quick identification of new safety information. You can help by reporting any side effects you may get. See the end of section 4 for how to report side effects.

#### **Read all of this leaflet carefully before you start using this medicine because it contains important information for you.**

- Keep this leaflet. You may need to read it again.
- If you have any further questions, ask your doctor, pharmacist or nurse.
- This medicine has been prescribed for you only. Do not pass it on to others. It may harm them, even if their symptoms of illness are the same as yours.
- If you get any side effects, talk to your doctor, pharmacist or nurse. This includes any possible side effects not listed in this leaflet. See section 4.

#### **What is in this leaflet**

1. What Ristempa is and what it is used for
2. What you need to know before you use Ristempa
3. How to use Ristempa
4. Possible side effects
5. How to store Ristempa
6. Contents of the pack and other information

#### **1. What Ristempa is and what it is used for**

Ristempa contains the active substance pegfilgrastim. Pegfilgrastim is a protein produced by biotechnology in bacteria called *E. coli*. It belongs to a group of proteins called cytokines, and is very similar to a natural protein (granulocyte-colony stimulating factor) produced by your own body.

Ristempa is used to reduce the duration of neutropenia (low white blood cell count) and the occurrence of febrile neutropenia (low white blood cell count with a fever) which can be caused by the use of cytotoxic chemotherapy (medicines that destroy rapidly growing cells). White blood cells are important as they help your body fight infection. These cells are very sensitive to the effects of chemotherapy which can cause the number of these cells in your body to decrease. If white blood cells fall to a low level there may not be enough left in the body to fight bacteria and you may have an increased risk of infection.

Your doctor has given you Ristempa to encourage your bone marrow (part of the bone which makes blood cells) to produce more white blood cells that help your body fight infection.

#### **2. What you need to know before you use Ristempa**

##### **Do not use Ristempa**

- if you are allergic to pegfilgrastim, filgrastim, *E. coli* derived proteins, or any of the other ingredients of this medicine.

## Warnings and precautions

Talk to your doctor, pharmacist or nurse before using Ristempa:

- if you experience an allergic reaction including weakness, drop in blood pressure, difficulty breathing, swelling of the face (anaphylaxis), redness and flushing, skin rash and areas of the skin that itch
- have an allergy to latex. The needle cap on the pre-filled syringe contains a derivative of latex and may cause severe allergic reactions
- experience a cough, fever and difficulty breathing. This can be a sign of Acute Respiratory Distress Syndrome (ARDS)
- if you have any of the following or combination of the following side effects:
  - swelling or puffiness, which may be associated with passing water less frequently, difficulty breathing, abdominal swelling and feeling of fullness, and a general feeling of tiredness

These could be symptoms of condition called “Capillary Leak Syndrome” which causes blood to leak from the small blood vessels into your body. See section 4.

- get left upper abdominal pain or pain at the tip of your shoulder. This may be a sign of a problem with your spleen (splenomegaly)
- have recently had a serious lung infection (pneumonia), fluid in the lungs (pulmonary oedema), inflammation of the lungs (interstitial lung disease) or an abnormal chest x-ray (lung infiltration)
- are aware of any altered blood cell counts (e.g. increase in white blood cells or anaemia) or decreased blood platelet counts, which reduces the ability of your blood to clot (thrombocytopenia). Your doctor may want to monitor you more closely
- have sickle cell anaemia. Your doctor may monitor your condition more closely.
- if you have sudden signs of allergy such as rash, itching or hives on the skin, swelling of the face, lips, tongue or other parts of the body, shortness of breath, wheezing or trouble breathing these could be signs of a severe allergic reaction.

Your doctor will check your blood and urine regularly as Ristempa can harm the tiny filters inside your kidneys (glomerulonephritis).

You should talk to your doctor about your risks of developing cancers of the blood. If you develop or are likely to develop cancers of the blood, you should not use Ristempa, unless instructed by your doctor.

### Loss of response to pegfilgrastim

If you experience a loss of response or failure to maintain a response with pegfilgrastim treatment, your doctor will investigate the reasons why including whether you have developed antibodies which neutralise pegfilgrastim’s activity.

### Other medicines and Ristempa

Tell your doctor or pharmacist if you are taking, have recently taken or might take any other medicines.

### Pregnancy and breast-feeding

Ask your doctor or pharmacist for advice before taking any medicine. Ristempa has not been tested in pregnant women. It is important to tell your doctor if you:

- are pregnant;
- think you may be pregnant; or
- are planning to have a baby.

If you become pregnant during Ristempa treatment, please inform your doctor. You may be encouraged to enrol in Amgen's Pregnancy Surveillance programme. Local representative contact details are provided in section 6 of this leaflet.

Unless your doctor directs you otherwise, you must stop breast feeding if you use Ristempa.

If you are nursing during Ristempa treatment, you may be encouraged to enrol in Amgen's Lactation Surveillance programme. Local representative contact details are provided in section 6 of this leaflet.

### **Driving and using machines**

Ristempa has no or negligible effect on the ability to drive or use machines.

### **Ristempa contains sorbitol (E420) and sodium acetate**

Ristempa contains sorbitol (a type of sugar). If you have been told by your doctor that you have an intolerance to some sugars, contact your doctor before taking this medicinal product.

This medicinal product contains less than 1 mmol (23 mg) sodium per 6 mg dose, i.e. essentially 'sodium-free'

## **3. How to use Ristempa**

Ristempa is for use in adults aged 18 and over.

Always take Ristempa exactly as your doctor has told you. You should check with your doctor or pharmacist if you are unsure. The usual dose is one 6 mg subcutaneous injection (injection under your skin) using a pre-filled syringe and it should be given at least 24 hours after your last dose of chemotherapy at the end of each chemotherapy cycle.

Do not shake Ristempa vigorously as this may affect its activity.

### **Injecting Ristempa yourself**

Your doctor may decide that it would be more convenient for you to inject Ristempa yourself. Your doctor or nurse will show you how to inject yourself. Do not try to inject yourself if you have not been trained.

For further instructions on how to inject yourself with Ristempa, please read the section at the end of this leaflet.

### **If you use more Ristempa than you should**

If you use more Ristempa than you should contact your doctor, pharmacist or nurse.

### **If you forget to inject Ristempa**

If you have forgotten a dose of Ristempa, you should contact your doctor to discuss when you should inject the next dose.

If you have any further questions on the use of this medicine, ask your doctor, pharmacist or nurse.

#### 4. Possible side effects

Like all medicines, this medicine can cause side effects, although not everybody gets them.

Please tell your doctor immediately if you have any of the following or combination of the following side effects:

- swelling or puffiness, which may be associated with passing water less frequently, difficulty breathing, abdominal swelling and feeling of fullness, and a general feeling of tiredness. These symptoms generally develop in a rapid fashion.

These could be symptoms of an uncommon (may affect up to 1 in 100 people) condition called “Capillary Leak Syndrome” which causes blood to leak from the small blood vessels into your body and needs urgent medical attention.

**Very common side effects** (may affect more than 1 in 10 people):

- bone pain. Your doctor will tell you what you can take to ease the bone pain.
- nausea and headaches.

**Common side effects** (may affect up to 1 in 10 people):

- pain at the site of injection.
- general aches and pains in the joints and muscles.
- some changes may occur in your blood, but these will be detected by routine blood tests. Your white blood cell count may become high for a short period of time. Your platelet count may become low which might result in bruising.

**Uncommon side effects** (may affect up to 1 in 100 people):

- allergic-type reactions, including redness and flushing, skin rash, and raised areas of the skin that itch.
- serious allergic reactions, including anaphylaxis (weakness, drop in blood pressure, difficulty breathing, swelling of the face).
- increased spleen size.
- spleen rupture. Some cases of splenic rupture were fatal. It is important that you contact your doctor immediately if you experience pain in the upper left side of the abdomen or left shoulder pain since this may relate to a problem with your spleen.
- breathing problems. If you have a cough, fever and difficulty breathing please tell your doctor.
- Sweet’s syndrome (plum-coloured, raised, painful lesions on the limbs and sometimes the face and neck with fever) has occurred but other factors may play a role.
- cutaneous vasculitis (inflammation of the blood vessels in the skin).
- damage to the tiny filters inside your kidneys (glomerulonephritis).
- redness at the site of injection.

#### Reporting of side effects

If you get any side effects, talk to your doctor, pharmacist or nurse. This includes any possible side effects not listed in this leaflet. You can also report side effects directly via the **national reporting system** listed in Appendix V. By reporting side effects you can help provide more information on the safety of this medicine.

#### 5. How to store Ristempa

Keep this medicine out of the sight and reach of children.

Do not use this medicine after the expiry date which is stated on the carton and on the syringe label after EXP. The expiry date refers to the last day of that month.

Store in a refrigerator (2°C – 8°C).

You may take Ristempa out of the refrigerator and keep it at room temperature (not above 30°C) for no longer than 3 days. Once a syringe has been removed from the refrigerator and has reached room temperature (not above 30°C) it must either be used within 3 days or disposed of.

Do not freeze. Ristempa may be used if it is accidentally frozen for a single period of less than 24 hours.

Keep the container in the outer carton in order to protect from light.

Do not use this medicine if you notice it is cloudy or there are particles in it.

Do not throw away any medicines via wastewater or household waste. Ask your pharmacist how to throw away medicines you no longer use. These measures will help to protect the environment.

## **6. Contents of the pack and other information**

### **What Ristempa contains**

- The active substance is pegfilgrastim. Each pre-filled syringe contains 6 mg of pegfilgrastim in 0.6 ml of solution.
- The other ingredients are sodium acetate, sorbitol (E420), polysorbate 20 and water for injections. See section 2.

### **What Ristempa looks like and contents of the pack**

Ristempa is a clear, colourless solution for injection in a pre-filled syringe (6 mg/0.6 ml).

Each pack contains 1 pre-filled syringe of type I glass with an attached stainless steel needle and needle cap. The syringes are provided with an automatic needle guard.

### **Marketing Authorisation Holder and Manufacturer:**

Amgen Europe B.V.  
Minervum 7061  
4817 ZK Breda  
The Netherlands

### **Marketing Authorisation Holder:**

Amgen Europe B.V.  
Minervum 7061  
4817 ZK Breda  
The Netherlands

### **Manufacturer:**

Amgen Technology (Ireland) Unlimited Company  
Pottery Road  
Dun Laoghaire  
Co. Dublin  
Ireland

For any information about this medicine, please contact the local representative of the Marketing Authorisation Holder.

### **België/Belgique/Belgien**

s.a. Amgen n.v.  
Tel/Tél: +32 (0)2 7752711

### **Lietuva**

Amgen Switzerland AG Vilniaus filialas  
Tel: +370 5 219 7474

**България**

Амджен България ЕООД  
Тел.: +359 (0)2 424 7440

**Česká republika**

Amgen s.r.o.  
Tel: +420 221 773 500

**Danmark**

Amgen filial af Amgen AB, Sverige  
Tlf: +45 39617500

**Deutschland**

AMGEN GmbH  
Tel.: +49 89 1490960

**Eesti**

Amgen Switzerland AG Vilniaus filialas  
Tel: +372 5125 501

**Ελλάδα**

Amgen Ελλάς Φαρμακευτικά Ε.Π.Ε.  
Τηλ.: +30 210 3447000

**España**

Amgen S.A.  
Tel: +34 93 600 18 60

**France**

Amgen S.A.S.  
Tél: +33 (0)9 69 363 363

**Hrvatska**

Amgen d.o.o.  
Tel: +385 (1) 562 57 20

**Ireland**

Amgen Limited  
United Kingdom  
Tel: +44 (0)1223 420305

**Ísland**

Vistor hf.  
Sími: +354 535 7000

**Italia**

Amgen S.r.l.  
Tel: +39 02 6241121

**Κύπρος**

Papaellinas & Co Ltd  
Τηλ.: +357 22741 741

**Luxembourg/Luxemburg**

s.a. Amgen  
Belgique/Belgien  
Tel/Tél: +32 (0)2 7752711

**Magyarország**

Amgen Kft.  
Tel.: +36 1 35 44 700

**Malta**

Amgen B.V.  
The Netherlands  
Tel: +31 (0)76 5732500

**Nederland**

Amgen B.V.  
Tel: +31 (0)76 5732500

**Norge**

Amgen AB  
Tel: +47 23308000

**Österreich**

Amgen GmbH  
Tel: +43 (0)1 50 217

**Polska**

Amgen Biotechnologia Sp. z o.o.  
Tel.: +48 22 581 3000

**Portugal**

Amgen Biofarmacêutica, Lda.  
Tel: +351 21 4220550

**România**

Amgen România SRL  
Tel: +4021 527 3000

**Slovenija**

AMGEN zdravila d.o.o.  
Tel: +386 (0)1 585 1767

**Slovenská republika**

Amgen Slovakia s.r.o.  
Tel: +421 33 321 13 22

**Suomi/Finland**

Amgen AB, sivuliike Suomessa/Amgen AB, filial  
i Finland  
Puh/Tel: +358 (0)9 54900500

**Sverige**

Amgen AB  
Tel: +46 (0)8 6951100



**Latvija**  
 Amgen Switzerland AG Rīgas filiāle  
 Tel: +371 292 84807

**United Kingdom**  
 Amgen Limited  
 Tel: +44 (0)1223 420305

**This leaflet was last revised in**

**Other sources of information**

Detailed information on this medicine is available on the European Medicines Agency web site:  
<http://www.ema.europa.eu>

Instructions for use:

Guide to parts

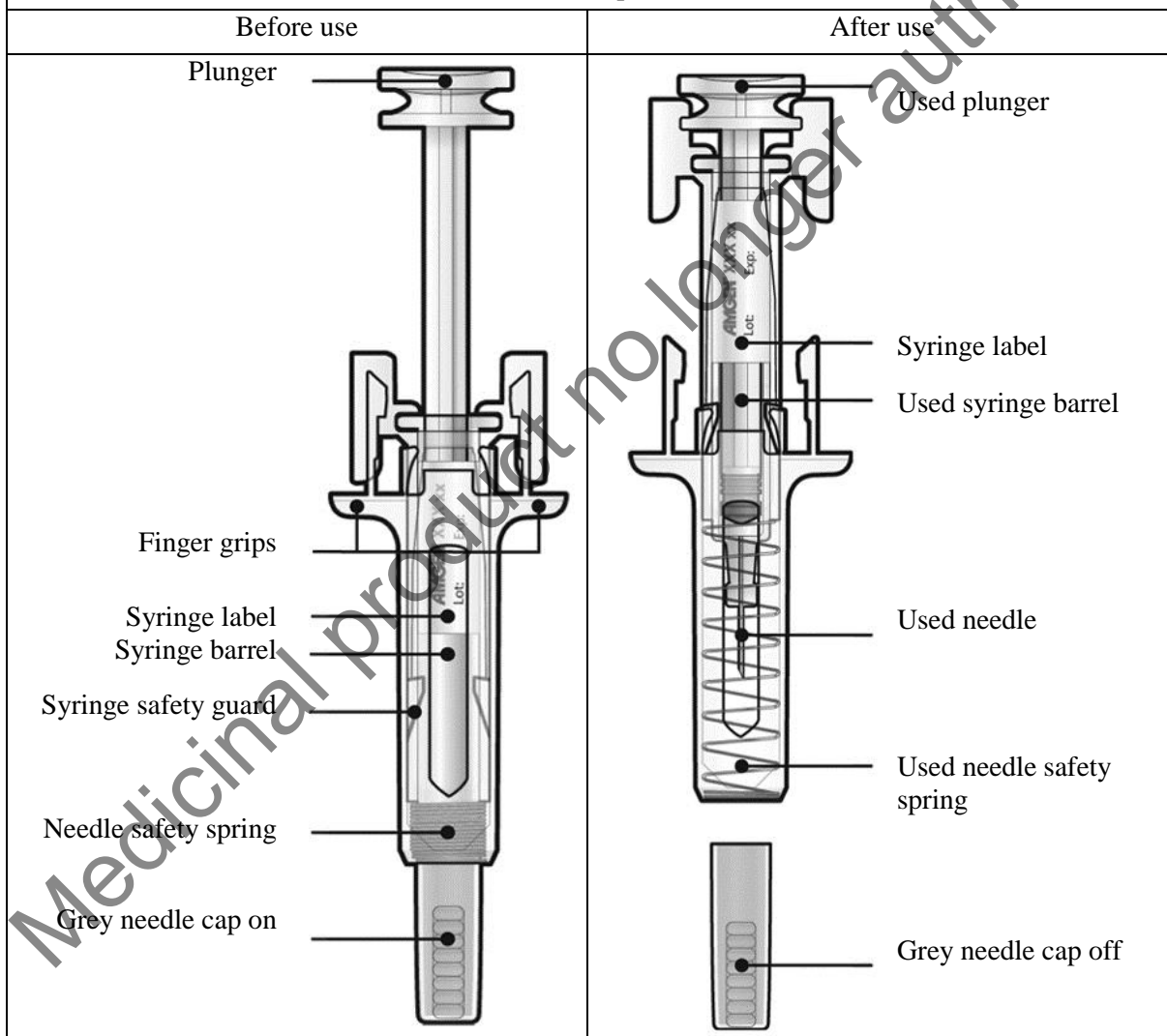

### Important

#### Before you use a Ristempa pre-filled syringe with automatic needle guard, read this important information:

- It is important that you do not try to give yourself the injection unless you have received training from your doctor or healthcare provider.
- Ristempa is given as an injection into the tissue just under the skin (subcutaneous injection).
- Tell your doctor if you have an allergy to latex. The needle cap on the pre-filled syringe contains a derivative of latex and may cause severe allergic reactions.
- ✗ **Do not** remove the grey needle cap from the pre-filled syringe until you are ready to inject.
- ✗ **Do not** use the pre-filled syringe if it has been dropped on a hard surface. Use a new pre-filled syringe and call your doctor or healthcare provider.
- ✗ **Do not** attempt to activate the pre-filled syringe prior to injection.
- ✗ **Do not** attempt to remove the clear pre-filled syringe safety guard from the pre-filled syringe.
- ✗ **Do not** attempt to remove the peelable label on the pre-filled syringe barrel before administering your injection.

Call your doctor or healthcare provider if you have any questions.

#### Step 1: Prepare

- A Remove the pre-filled syringe tray from the package and gather the supplies needed for your injection: alcohol wipes, a cotton ball or gauze pad, a plaster and a sharps disposal container (not included).

For a more comfortable injection, leave the pre-filled syringe at room temperature for about 30 minutes before injecting. Wash your hands thoroughly with soap and water.

On a clean, well-lit work surface, place the new pre-filled syringe and the other supplies.

- ✗ **Do not** try to warm the syringe by using a heat source such as hot water or microwave.
- ✗ **Do not** leave the pre-filled syringe exposed to direct sunlight.
- ✗ **Do not** shake the pre-filled syringe.
- **Keep pre-filled syringes out of the sight and reach of children.**

- B Open the tray, peeling away the cover. Grab the pre-filled syringe safety guard to remove the pre-filled syringe from the tray.

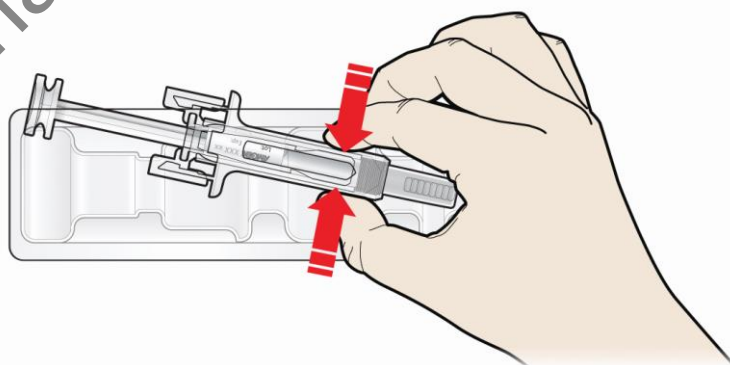

**Grab here**

For safety reasons:

- ✗ **Do not** grasp the plunger.
- ✗ **Do not** grasp the grey needle cap.

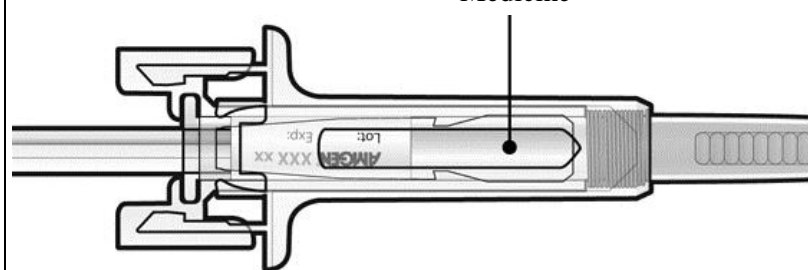
C	Inspect the medicine and pre-filled syringe.
<p style="text-align: center;">Medicine</p> 	
<p><b>x Do not</b> use the pre-filled syringe if:</p> <ul style="list-style-type: none"> <li>• The medicine is cloudy or there are particles in it. It must be a clear and colourless liquid.</li> <li>• Any part appears cracked or broken.</li> <li>• The grey needle cap is missing or not securely attached.</li> <li>• The expiry date printed on the label has passed the last day of the month shown.</li> </ul> <p>In all cases, call your doctor or healthcare provider.</p>	

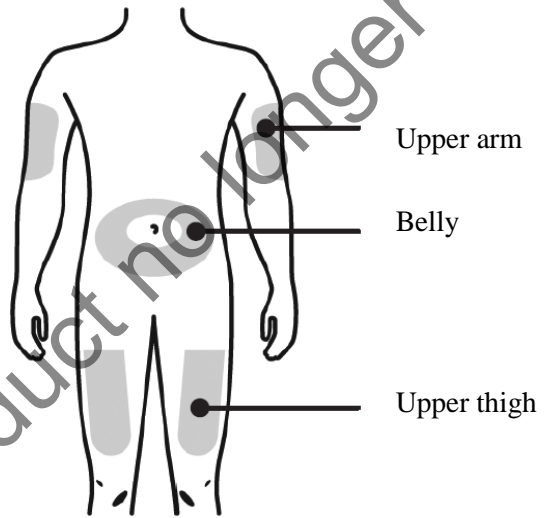
Step 2: Get ready	
A	Wash your hands thoroughly. Prepare and clean your injection site.
<div style="text-align: center;">  </div> <p><b>You can use:</b></p> <ul style="list-style-type: none"> <li>• Upper part of your thigh.</li> <li>• Belly, except for a 5 cm (2-inch) area right around your belly button.</li> <li>• Outer area of upper arm (only if someone else is giving you the injection).</li> </ul> <p>Clean the injection site with an alcohol wipe. Let your skin dry.</p> <p><b>x Do not</b> touch the injection site before injecting.</p> <p><b>!</b> <b>Do not</b> inject into areas where the skin is tender, bruised, red, or hard. Avoid injecting into areas with scars or stretch marks.</p>	

B Carefully pull the grey needle cap straight out and away from your body.

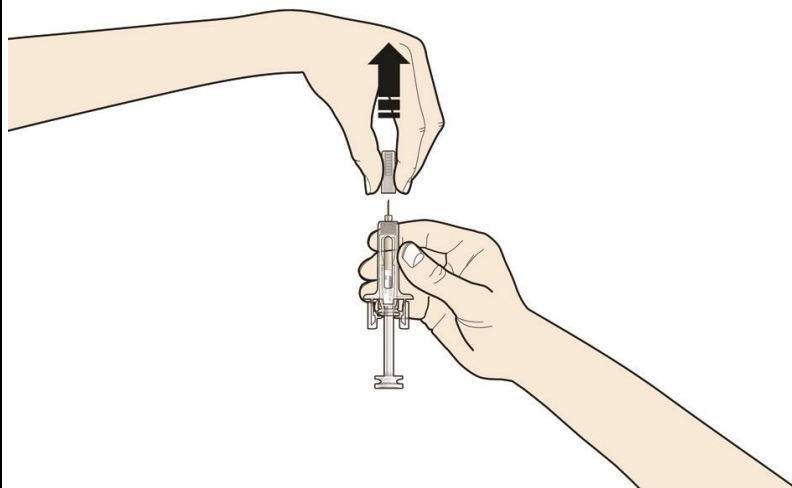

C Pinch your injection site to create a firm surface.

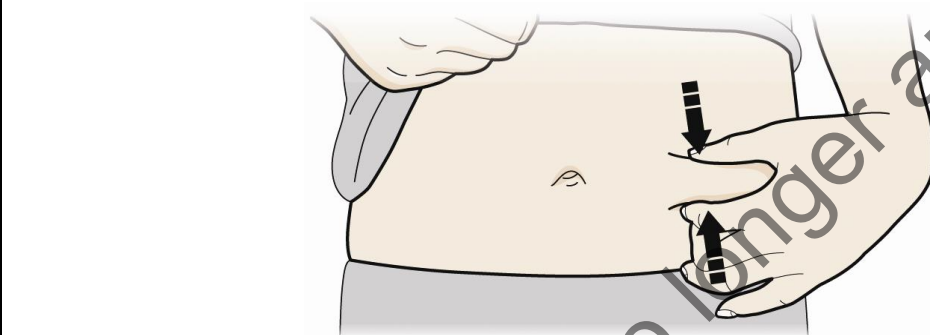

It is important to keep the skin pinched when injecting.

Step 3: Inject

A Hold the pinch. INSERT the needle into skin.

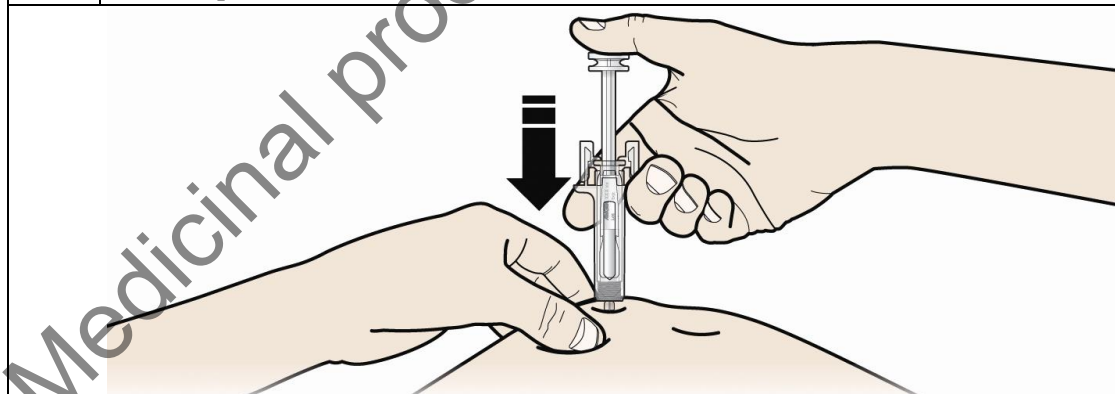

**x** Do not touch the cleaned area of the skin.

B PUSH the plunger with slow and constant pressure until you feel or hear a “snap”. Push all the way down through the snap.

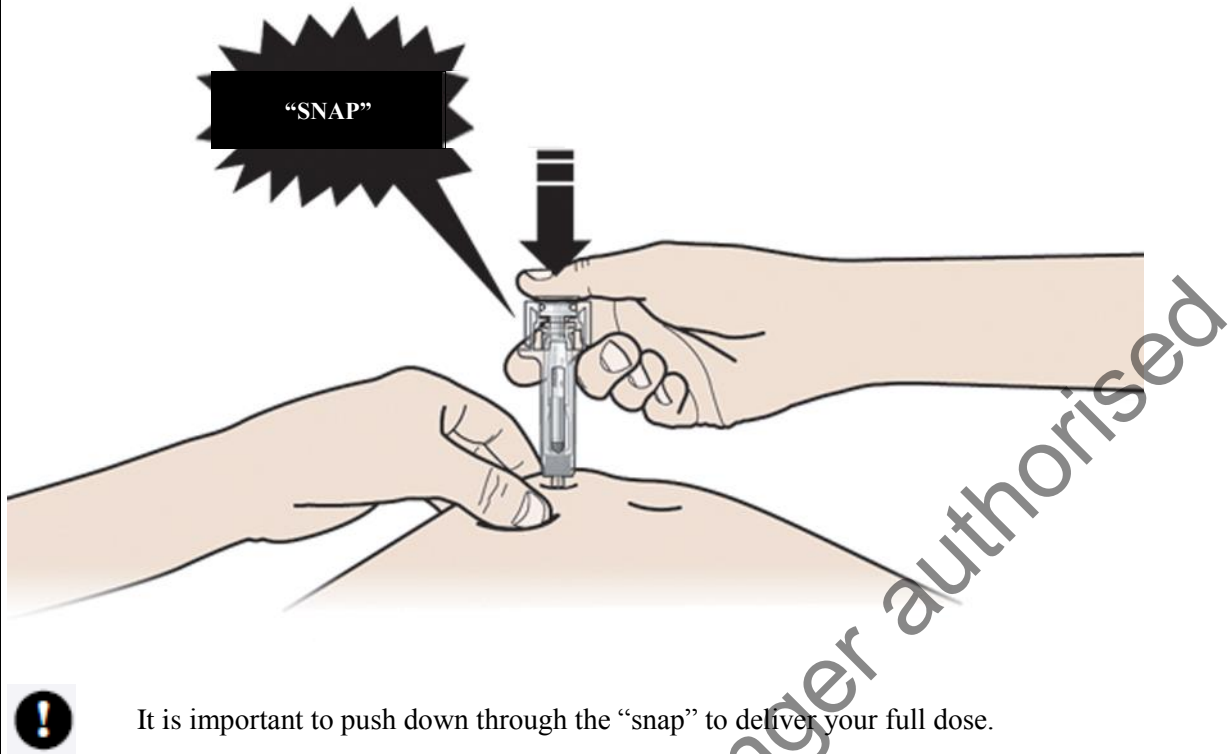

C RELEASE your thumb. Then LIFT the syringe off skin.

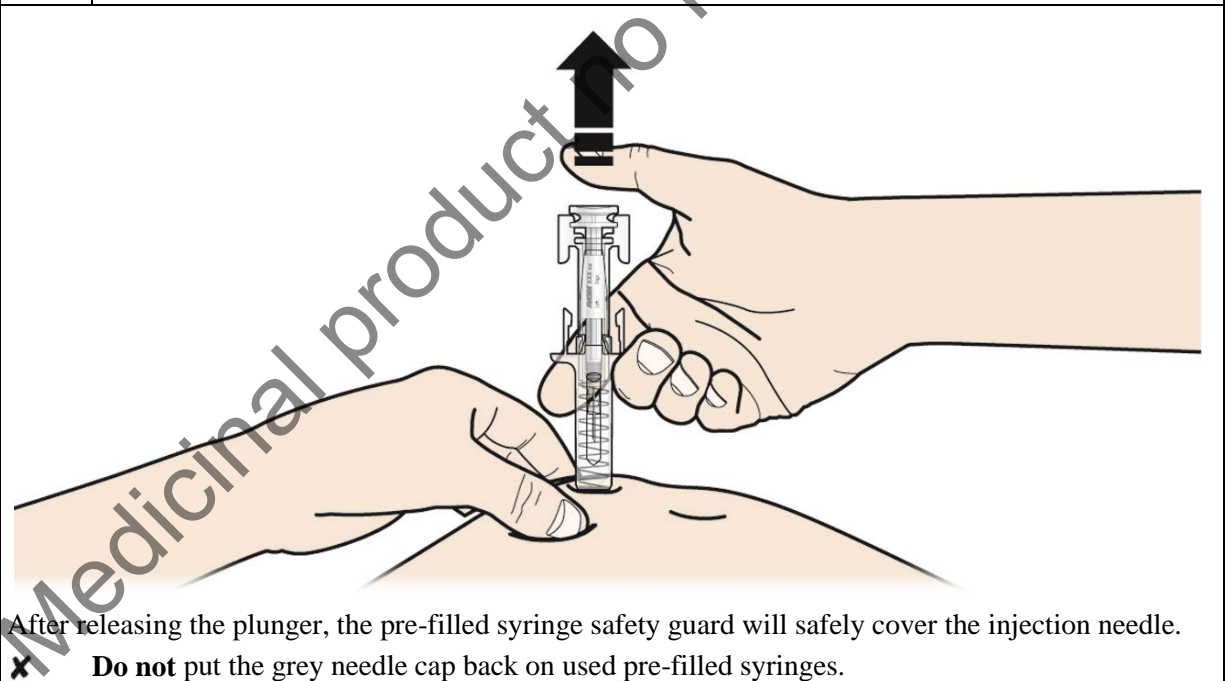

**Healthcare professionals only**

The trade name of the administered product should be clearly recorded in the patient file.

Remove and save the pre-filled syringe label.

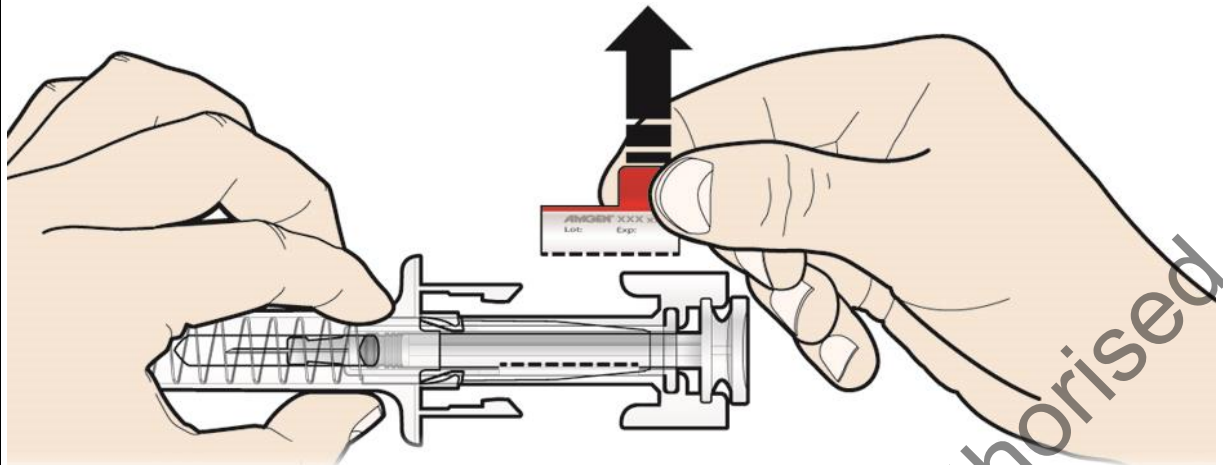

Turn the plunger to move the label into a position where you can remove the syringe label.

**Step 4: Finish**

A Discard the used pre-filled syringe and other supplies in a sharps disposal container.

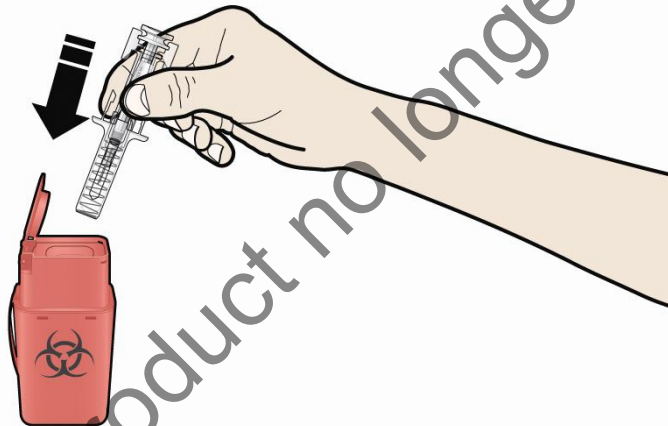

Medicines should be disposed of in accordance with local requirements. Ask your pharmacist how to dispose of medicines no longer required. These measures will help to protect the environment.

Keep the syringe and sharps disposal container out of sight and reach of children.

- ✗ **Do not** reuse the pre-filled syringe.
- ✗ **Do not** recycle pre-filled syringes or throw them into household waste.

B Examine the injection site.



If there is blood, press a cotton ball or gauze pad on your injection site. **Do not** rub the injection site. Apply a plaster if needed.

Separate additional insert:

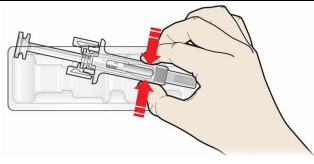
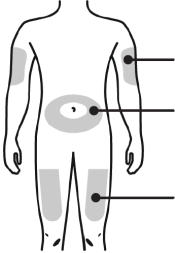
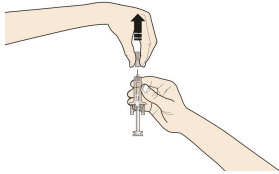
Front – Ristempa reference guide:

Reference Guide – Read all instructions found in the carton before use				
ENGLISH	1	2	3	Side 1
	 <p><b>Grab here</b></p>	 <p>Upper arm Belly Upper thigh</p>		Turn over to continue...
	Open tray, peeling away cover. Grab pre-filled syringe safety guard to remove pre-filled syringe from tray.	Wash hands thoroughly. Prepare and clean your injection site.	Carefully pull grey needle cap straight out and away from your body.	

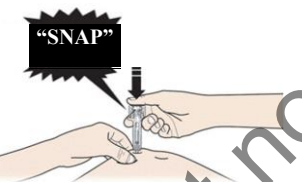
Back- Ristempa reference guide:

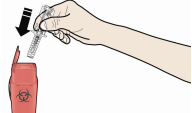
ENGLISH	4	5	6	7	Side 2
					Read other side first
	Pinch and hold the skin. INSERT needle into skin.	PUSH plunger with slow and constant pressure until you feel or hear a "snap". Push all the way down through the snap.	RELEASE your thumb. Then LIFT syringe off skin.	Discard used pre-filled syringe and other supplies in a sharps disposal container.	