

**ANNEX I**  
**SUMMARY OF PRODUCT CHARACTERISTICS**

▼ This medicinal product is subject to additional monitoring. This will allow quick identification of new safety information. Healthcare professionals are asked to report any suspected adverse reactions. See section 4.8 for how to report adverse reactions

## **1. NAME OF THE MEDICINAL PRODUCT**

Sixmo 74.2 mg implant

## **2. QUALITATIVE AND QUANTITATIVE COMPOSITION**

Each implant contains buprenorphine hydrochloride equivalent to 74.2 mg of buprenorphine.

For the full list of excipients, see section 6.1.

## **3. PHARMACEUTICAL FORM**

Implant

White/Off-white to pale yellow, rod-shaped implant, 26.5 mm long and 2.4 mm in diameter.

## **4. CLINICAL PARTICULARS**

### **4.1 Therapeutic indications**

Sixmo is indicated for substitution treatment for opioid dependence in clinically stable adult patients who require no more than 8 mg/day of sublingual buprenorphine, within a framework of medical, social and psychological treatment.

### **4.2 Posology and method of administration**

Treatment must be under the supervision of a healthcare professional experienced in the management of opioid dependence/addiction. Insertion and removal of the Sixmo implants must be performed by a physician who is competent in minor surgery and has been trained to conduct the insertion and removal procedure. Appropriate precautions, such as the conduct of patient follow-up visits according to the patient's needs and the treating physician's clinical judgement, should be taken during Sixmo treatment.

Patients previously treated with sublingual buprenorphine or sublingual buprenorphine + naloxone, must be on stable doses between 2 to 8 mg/day for at least 30 days and deemed clinically stable by the treating healthcare professional.

The following factors should be considered when determining clinical stability and suitability for Sixmo treatment:

- period free from opioid drug abuse
- stability of living environment
- participation in a structured activity/job
- consistency in participation in recommended behavioural therapy/peer support programme
- consistency in compliance with clinic visit requirements
- minimal to no desire or need to abuse opioids
- period without episodes of hospitalisations (addiction or mental health issues), emergency room visits, or crisis interventions
- social support system

## Posology

Sixmo should be used only in patients who are opioid tolerant. Each dose consists of four implants, for subcutaneous insertion in the inner side of the upper arm.

Sixmo implants are intended to be in place for 6 months of treatment and provide a sustained delivery of buprenorphine. They are removed by the end of the sixth month.

### *Treatment with Sixmo*

Sublingual buprenorphine should be discontinued 12 to 24 hours prior to subcutaneous insertion of Sixmo implants.

### *Criteria for the use of supplemental sublingual buprenorphine*

It is possible that a subset of patients may require occasional supplemental sublingual buprenorphine support to achieve full control of opioid withdrawal symptoms and cravings, e.g. at times of personal stress or crisis.

The administration of additional buprenorphine sublingual doses should be considered by the treating physician if:

- the patient experiences withdrawal symptoms, e.g. sweating, lacrimation, yawning, nausea, vomiting, tachycardia, hypertension, piloerection, dilated pupils;
- in case of patient's self-reported heroin use, other opioid use or craving and/ or urine samples positive for opioids

Although some patients may require occasional supplemental dosing with buprenorphine, patients should not be provided with prescriptions for sublingual buprenorphine-containing products for as-needed use. Instead, patients who feel the need for supplemental dosing should be seen and evaluated promptly.

### *Treatment discontinuation criteria*

The treating physician should consider implant removal if:

- the patient experiences severe or intolerable side effects (including severe precipitated withdrawal);
- signs of intoxication or overdose appear (miosis, lip cyanosis, sedation, bradycardia, hypotension, respiratory depression);
- the patient experiences lack of efficacy, as evidenced by lasting withdrawal symptoms that require repeated management with sublingual buprenorphine

### *Discontinuation*

Patients who discontinue treatment with Sixmo should be switched back to their previous dose of sublingual buprenorphine within 12 to 24 hours following removal of the Sixmo implants (i.e. the dose from which they were transferred prior to starting Sixmo treatment). The dissociation of buprenorphine from the  $\mu$ -opioid receptors is expected to take up to several days after discontinuation of Sixmo treatment, which will prevent withdrawal symptoms immediately after removal of Sixmo.

### *Retreatment*

If continued treatment is desired at the end of the first six-month treatment cycle, a new set of 4 Sixmo implants may be administered following removal of the old implants for one additional treatment cycle of six months. The experience of a second treatment cycle is limited. There is no experience of re-implantation beyond 12 months. Implants should be inserted in the inner side of the opposite upper arm, following the insertion steps below to locate the appropriate insertion site.

Implants for repeat treatment should be inserted subcutaneously as soon as possible after removal of the previous implants, preferably on the same day. If implants for repeat treatment are not inserted on the same day as removal of previous implants, individuals should be maintained on a fixed dose of 2 to 8 mg/day of sublingual buprenorphine, as clinically indicated, until repeat treatment occurs. Sublingual buprenorphine should be discontinued 12 to 24 hours prior to insertion of four Sixmo implants.

After one subcutaneous insertion in each arm (for a total of two treatment cycles), most patients should be transitioned back to their previous sublingual buprenorphine dose (i.e. the dose from which they were transferred to Sixmo treatment) for continued treatment. There are no prospective data with Sixmo beyond two treatment cycles, and there is no experience with inserting Sixmo implants into other sites of the arm, sites other than the upper arm or re-insertion into previously-used sites.

#### Special populations

##### *Elderly*

Clinical studies of Sixmo did not include patients over 65 years and, therefore, the use of the product in this population is not recommended. The efficacy and safety of buprenorphine in elderly patients > 65 years has not been established. No recommendation on posology can be made.

##### *Hepatic impairment*

Because buprenorphine levels cannot be adjusted during Sixmo treatment, Sixmo is contraindicated in patients with severe hepatic impairment (Child-Pugh C) (sections 4.3, 4.4 and 5.2). Patients with mild to moderate hepatic impairment (Child-Pugh A and B) should be monitored for signs and symptoms of toxicity or overdose caused by increased levels of buprenorphine (miosis, lip cyanosis, sedation, bradycardia, hypotension, respiratory depression). In case toxicity or overdose symptoms are observed, the removal of the implants and transition to a medicinal product that allows dose adjustment are required.

Patients who develop hepatic impairment while being treated with Sixmo should be monitored for signs and symptoms of toxicity or overdose. In case toxicity or overdose symptoms develop, the removal of the implants and transition to a medicinal product that allows dose adjustment are required.

##### *Renal impairment*

Renal elimination plays a relatively small role (approximately 30%) in the overall clearance of buprenorphine and buprenorphine plasma concentrations were not increased in patients with renal impairment.

Modification of the Sixmo dose is not required in patients with renal impairment. Caution is recommended when dosing patients with severe renal impairment (creatinine clearance < 30 mL/min) (see sections 4.4 and 5.2).

##### *Paediatric population*

The safety and efficacy of Sixmo in children under 18 years have not yet been established. No data are available.

#### Method of administration

##### Subcutaneous use

##### *Preparations for handling or administering the medicinal product*

- The insertion and removal of Sixmo should take place under aseptic conditions.
- The patient should be able to lie on their back.
- It is recommended that the healthcare professional is in a seated position during the entire insertion procedure so that the insertion site and the movement of the needle under the skin can be clearly seen from the side. Only a healthcare professional who is competent in minor surgery and is trained in the insertion of Sixmo should perform the procedure, using only the implant applicator, with the recommended local anaesthetic available.
- One applicator is used to insert all four implants.
- Please note that an ultrasound and MRI facilities need to be available to the clinical site at which the insertion and removal of Sixmo occurs.
- Patients who have contraindications for MRI should be not allowed to receive the implant.

### *Equipment for subcutaneous insertion of Sixmo*

The following equipment is needed for implant insertion under aseptic conditions:

- an examination table for the patient to lie on
- instrument stand covered with sterile drape
- adequate lighting, such as headlamp
- sterile fenestrated drape
- latex, talc-free sterile gloves
- alcohol pad
- surgical marker
- antiseptic solution, such as chlorhexidine
- local anaesthetic, such as 1% lidocaine with adrenaline 1:100,000
- 5 mL syringe with 25G×1.5" needle (0.5×38 mm)
- Adson single tooth tissue forceps
- #15 blade scalpel
- thin adhesive strip around 6 mm wide (butterfly strip)
- 100×100 mm sterile gauze
- adhesive bandages
- pressure bandage around 8 cm wide
- liquid adhesive
- 4 Sixmo implants
- 1 implant applicator

The implant applicator (disposable) and its parts are shown in Figure 1.

Figure 1

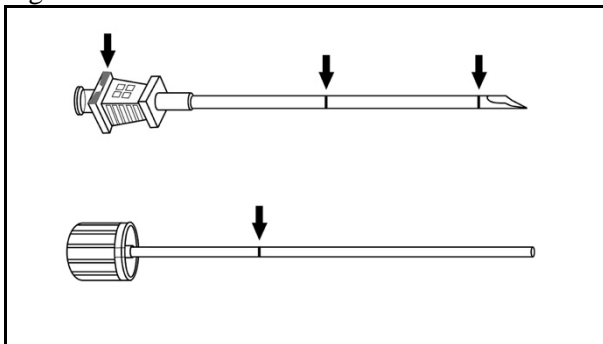

### *Instructions for subcutaneous insertion of Sixmo*

**Step 1:** The patient should lie on their back, with the intended arm flexed at the elbow and externally rotated, so that the hand is positioned next to the head. Identify the insertion site, which is at the inner side of the upper arm, about 80 to 100 mm (8 to 10 cm) above the medial epicondyle, in the sulcus between the biceps and triceps muscle. Having the patient flex the biceps muscle may facilitate identification of the site (Figure 2).

Figure 2

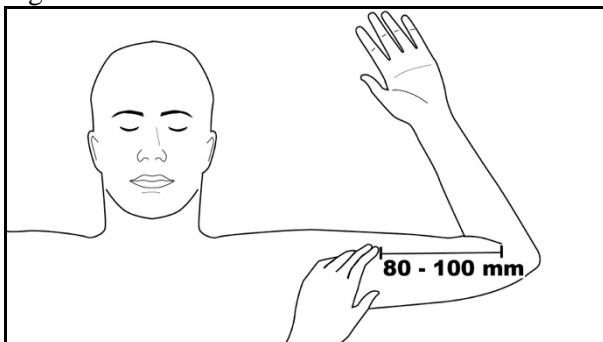

**Step 2:** Clean the insertion site with an alcohol pad. Mark the insertion site with the surgical marker.

The implants will be inserted through a small 2.5 to 3 mm subcutaneous incision. Mark the channel tracks where each implant will be inserted by drawing 4 lines - with each line 40 mm long. The implants will be positioned in a close fan-shaped distribution 4 to 6 mm apart, with the fan opening towards the shoulder (Figure 3).

Figure 3

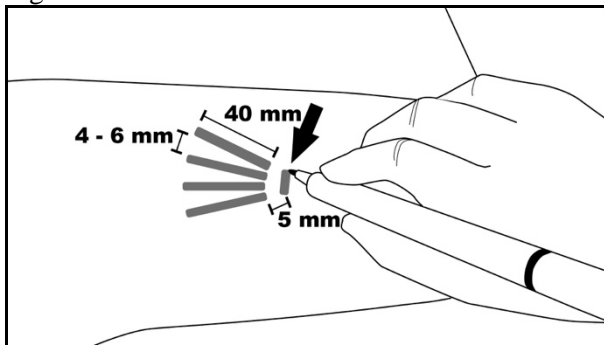

**Step 3:** Put on sterile gloves and check the function of the implant applicator by removing the obturator from the cannula and relocking it. Clean the insertion site with an antiseptic solution, such as chlorhexidine. Do not blot or wipe away.

Apply the sterile fenestrated drape to the patient's arm (Figure 4). Anaesthetise the insertion area at the incision site and just under the skin, along the planned insertion channels, by injecting 5 mL lidocaine 1% with adrenaline 1:100,000. After determining that anaesthesia is adequate and effective, make a shallow incision 2.5 to 3 mm in length at incision site marking.

Figure 4

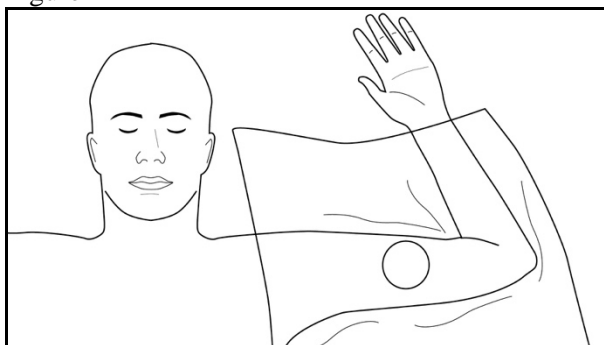

**Step 4:** Lift the edge of the incision opening with the toothed forceps. While applying counter-traction to the skin, at a slight angle (no greater than 20 degrees), insert only the tip of the applicator into the subcutaneous space (depth of 3 to 4 mm below the skin), with the bevel-up stop marking on the cannula facing upwards and visible with the obturator locked fully into the cannula (Figure 5).

Figure 5

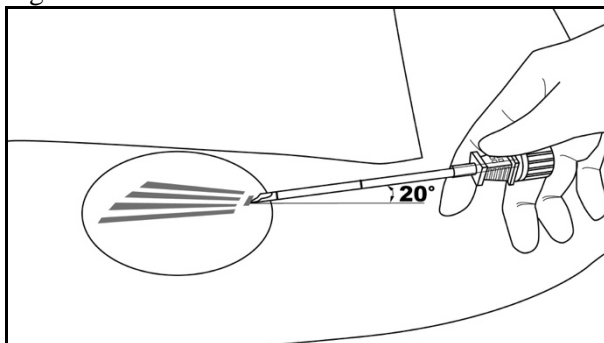

**Step 5:** Lower the applicator to a horizontal position; lift the skin up with the tip of the applicator, but keep the cannula in the subcutaneous connective tissue (Figure 6).

Figure 6

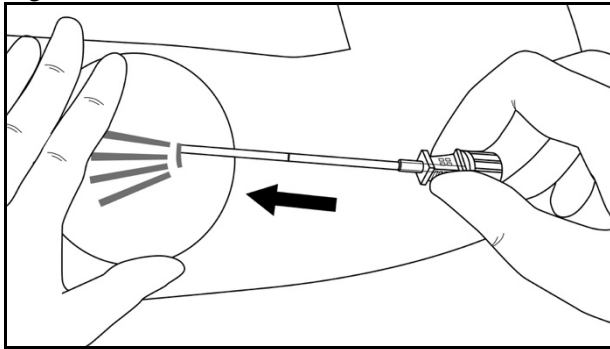

**Step 6:** While lifting, gently advance the applicator subcutaneously along the channel marking on the skin. Stop immediately once the proximal marking on the cannula has disappeared into the incision (Figures 7 and 8).

Figure 7

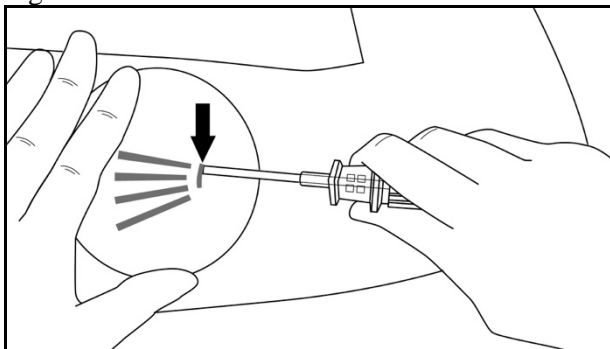
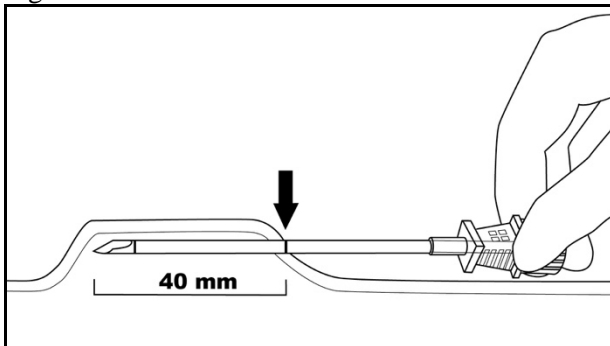

Figure 8



**Step 7:** While holding the cannula in place, unlock the obturator and remove the obturator. Insert one implant into the cannula (Figure 9), re-insert the obturator, and gently push the obturator forward (mild resistance should be felt) until the obturator stop line is level with the bevel-up stop marking, which indicates the implant is positioned at the tip of the cannula (Figure 10). **Do not force the implant beyond the end of the cannula with the obturator.** There should be at least 5 mm between the incision and the implant when the implant is properly positioned.

Figure 9

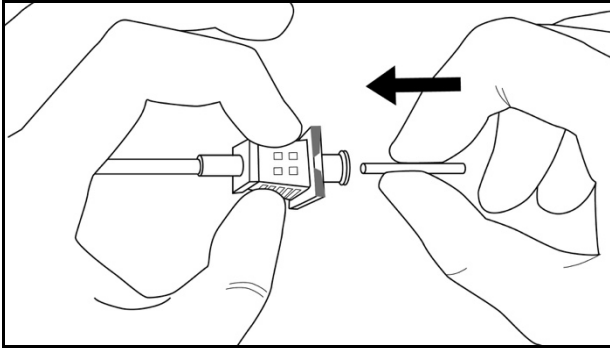
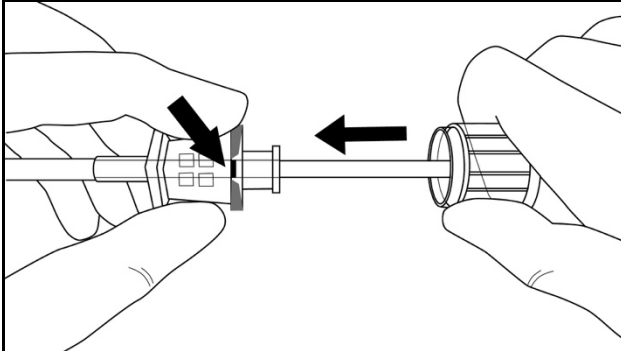

Figure 10



**Step 8:** While holding the obturator in place on the arm, retract the cannula along the obturator, leaving the implant in place (Figure 11). **Note: Do not push the obturator.** Withdraw the cannula until the hub is flush with the obturator, then twist the obturator clockwise to lock onto the cannula (Figure 12). Retract the applicator, bevel-up, until the distal marking of the cannula is visible at the incision opening (the sharp tip remaining in the subcutaneous space).

Figure 11

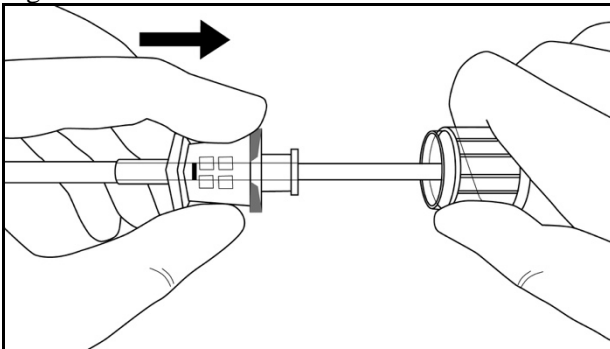
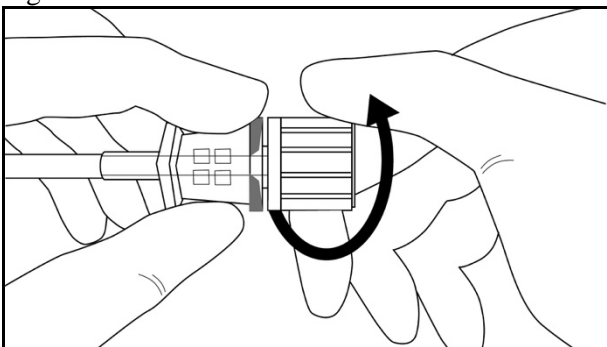

Figure 12



**Step 9:** Redirect the applicator to the next channel marking, while stabilizing the previously inserted implant with your index finger, away from the sharp tip (Figure 13). Follow steps 6 through 9 for the



insertion of the three remaining implants through the same incision.

Figure 13

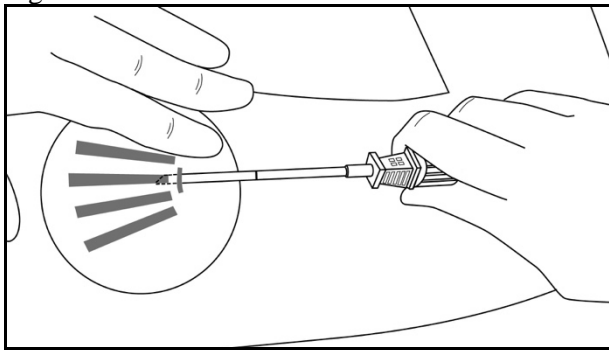

**Step 10:** Verify the presence of each implant (26.5 mm in length) by palpation of the patient's arm immediately after the insertion, as shown in Figure 14. If you cannot feel each of the four implants, or doubt their presence, use other methods to confirm the presence of the implant.

Figure 14

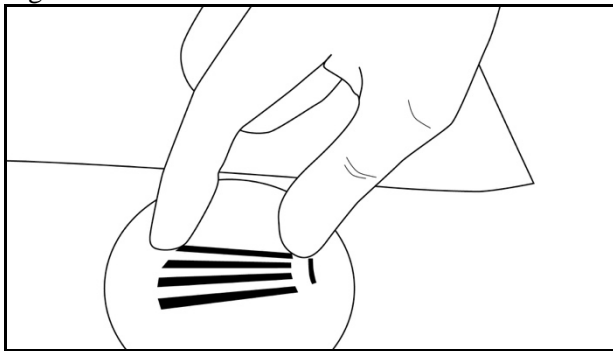

**Step 11:** Apply pressure to the incision site for approximately five minutes if necessary. Clean the incision site. Apply liquid adhesive to the skin margins and allow to dry before closing the incision with the thin adhesive strip around 6 mm wide (butterfly strip). Place a small adhesive bandage over the insertion site. Apply a pressure bandage with sterile gauze to minimize bruising. Instruct the patient that the pressure bandage can be removed after 24 hours and the adhesive bandage removed in three to five days, and to apply an ice pack on the arm for 40 minutes every two hours for the first 24 hours, then as needed.

**Step 12:** Complete the Patient Alert Card and give it to the patient to keep. Also, scan or input the details of the implant procedure into the patient's medical records. Advise the patient on proper care of the insertion site.

#### *Instruction for location of implants prior to removal*

Verify the location of the implants by palpation. **Non-palpable implants must be located prior to attempted removal.** In the case of non-palpable implants, removal should be performed under ultrasound guidance (following their localisation). Suitable methods for location include ultrasound with a high frequency linear array transducer (10 MHz or greater) or, in case ultrasound is not successful, magnetic resonance imaging (MRI). Sixmo implants are not radiopaque and cannot be seen by X-ray or CT scan. Exploratory surgery without knowledge of the exact location of all implants is strongly discouraged (see section 4.4).

#### *Equipment for removal of Sixmo*

Implants should be removed under aseptic conditions, whereby the following equipment is needed:

- an examination table for the patient to lie on
- instrument stand covered with sterile drape
- adequate lighting, such as headlamp

- sterile fenestrated drapes
- latex, talc-free, sterile gloves
- alcohol pad
- surgical marker
- antiseptic solution, such as chlorhexidine
- local anaesthetic, such as 1% lidocaine with adrenaline 1:100,000
- 5 mL syringe with 25G×1.5" needle (0.5×38 mm)
- Adson single tooth tissue forceps
- mosquito forceps
- two X-plant clamps (vasectomy fixation clamps with 2.5 mm ring diameter)
- iris scissors
- needle driver
- #15 blade scalpel
- sterile ruler
- 100×100 mm sterile gauze
- adhesive bandage
- pressure bandage around 8 cm wide
- sutures, such as 4-0 Prolene™ with an FS-2 cutting needle (may be absorbable)

*Instructions for removal of Sixmo*

**Step 13:** The patient should lie on their back, with the implant arm flexed at the elbow and externally rotated, so that the hand is positioned next to the head. Reconfirm the location of the implants by palpation. Clean removal site with alcohol pad prior to marking the skin. Using the surgical marker, mark the location of the implants and the location of the incision. The incision should be made parallel to the axis of the arm, between the second and third implants, to access the subcutaneous space (Figure 15).

Figure 15

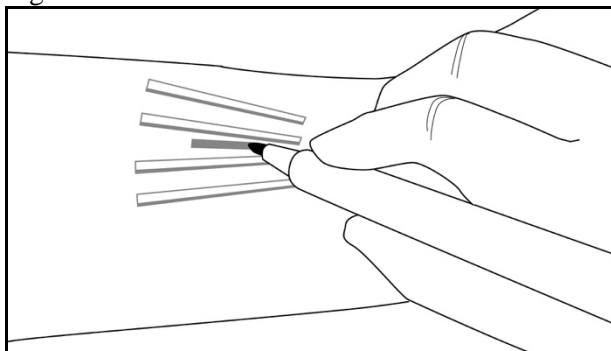

**Step 14:** Put on sterile gloves. Using aseptic technique, place the sterile equipment on the sterile field of the instrument stand. Clean the removal site with an antiseptic solution, such as chlorhexidine. Do not blot or wipe away. Apply the sterile drape to the patient's arm. Anaesthetise the incision site and the subcutaneous space containing the implants (for example, by injecting 5 to 7 mL lidocaine 1% with adrenaline 1:100,000).

NOTE: Be sure to inject the local anaesthetic deep to the centre of the implants; this will effectively lift the implants toward the skin, facilitating removal of the implants. After determining the anaesthesia is adequate and effective, make a 7 to 10 mm incision with a scalpel, parallel to the axis of the arm, between the second and third implants.

**Step 15:** Pick up the skin edge with Adson single toothed tissue forceps and separate the tissues above and below the visible implant, using an iris scissors or a curved mosquito forceps (Figure 16). Grasp the centre of the implant with the X-plant clamp(s) (Figure 17) and apply gentle traction. If the implant is encapsulated, or you see dimpling, use the scalpel to shave the adhering tissue to release the implant.

Figure 16

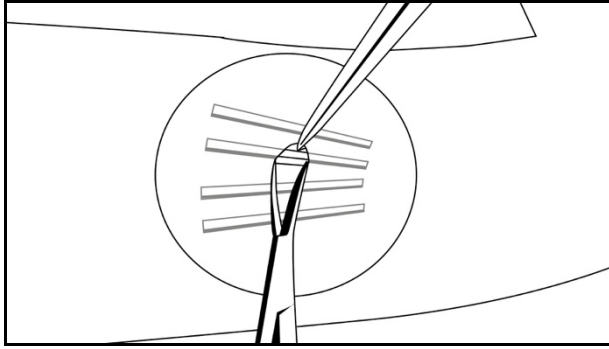
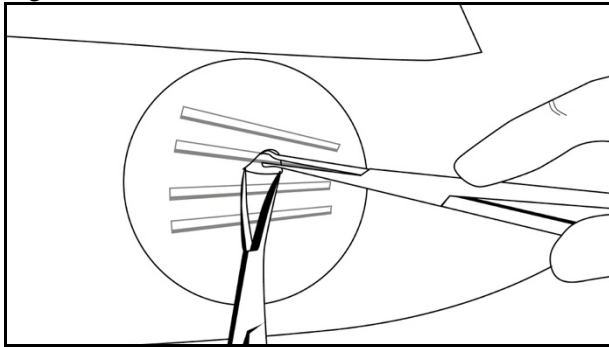

Figure 17



**Step 16:** After removal of each implant, confirm that the entire 26.5 mm long implant has been removed by measuring its length. Follow steps 15 and 16 for the removal of the remaining implants through the same incision. The same technique is employed for the removal of protruding or partially expelled implants. Exploratory surgery without knowledge of the exact location of all implants is strongly discouraged (see section 4.4).

**Step 17:** After removal of all implants, clean the incision site. Close the incision with sutures. Place an adhesive bandage over the incision. Use the sterile gauze and apply gentle pressure to the incision site, for five minutes, to ensure haemostasis. Apply a pressure bandage with sterile gauze to minimize bruising. Instruct the patient that the pressure bandage can be removed after 24 hours and the adhesive bandage in three to five days. Counsel the patient on proper aseptic wound care. Instruct the patient to apply an ice pack to the arm for 40 minutes every two hours for first 24 hours, then as needed. Schedule an appointment for the sutures to be removed.

**Step 18:** Disposal of Sixmo implants should be in accordance with local requirements as it contains buprenorphine.

If implant(s) or implant fragment(s) are not removed during a removal attempt, the patient should undergo imaging for localisation as soon as is feasible with the subsequent removal attempt performed on the same day as localisation. If localisation and a second removal attempt are not performed on the same day as the initial removal attempt, the wound should be closed with sutures in the interim.

### 4.3 Contraindications

Hypersensitivity to the active substance or to any of the excipients listed in section 6.1.

Severe respiratory insufficiency

Severe hepatic impairment

Acute alcoholism or delirium tremens

Concomitant administration of opioid antagonists (naltrexone, nalmefene) for the treatment of alcohol or opioid dependence

Patients with a history of keloid or hypertrophic scar formation should not undergo subcutaneous insertion, as difficulties in retrieving the implant are possible.

Patients who have contraindications for MRI.

### 4.4 Special warnings and precautions for use

#### Treatment monitoring

Patients may experience somnolence, especially in the first week following insertion of the implants and should be cautioned in this respect (see section 4.7).

The insertion site should be examined one week following implant insertion and regularly thereafter for signs of infection or any problems with wound healing, including evidence of implant extrusion from the skin as well as misuse or abuse. The recommended visit schedule for most patients is a frequency of no less than once-monthly for continued counselling and psychosocial support.

#### Serious complications from insertion and removal of Sixmo implants

Rare but serious complications, including nerve damage and migration resulting in embolism and death, may result from improper insertion of drug implants in the upper arm. Additional complications may include local migration, protrusion, expulsion and implant breakage after insertion or during removal. Surgical intervention is necessary for removing an implant that has migrated.

Subcutaneous insertion is essential to confirm proper placement by palpation. If implants are placed too deeply (intramuscular or in the fascia) this may lead to neural or vascular injury upon insertion or removal.

Infection may occur at the site of the insertion or removal. Excessive palpation shortly after insertion of the implants may increase the chance of infection. Improper removal carries risk of implant-site infection and implant breakage.

In rare cases, implants or partial implants could not be localized and were, therefore, not removed (see section 4.2).

#### Expulsion of the implant

If spontaneous expulsion of the implant occurs after insertion, the following steps should be taken:

- An appointment for the patient should be scheduled to return to the inserting healthcare professional as soon as possible.
- The patient should be instructed to place the implant in a glass jar with a lid, store it safely away from others, especially children, and bring it to the healthcare professional to determine whether the full implant has been expelled.  
Please note: Buprenorphine can cause severe, possibly fatal, respiratory depression in children who are accidentally exposed to it.
- If the patient returns the expelled implant, it should be measured to ensure that the entire implant was expelled (26.5 mm in length).
- The incision site should be inspected for infection. If infected, it should be treated appropriately and be determined if remaining implants need to be removed.

- If the expelled implant is not intact, the healthcare professional should palpate the insertion location to identify the location of any remaining partial implant. The remaining partial implant should be removed using the techniques described in section 4.2 under “Instructions for removal of Sixmo”.
- If it is not possible to palpate the remaining implant, an ultrasound or MRI should be performed per techniques described in section 4.2 under “Instructions for removal of Sixmo”.
- The healthcare professional must carefully monitor the patient until the implant is replaced to evaluate for withdrawal or other clinical indicators suggesting that supplemental sublingual buprenorphine may be needed.
- The replacement implant(s) should be inserted in same arm either medially or laterally to *in situ* implants. Alternatively, replacement implant(s) may be inserted in the contralateral arm.

### Misuse and diversion

Buprenorphine has the potential to be abused and is prone to criminal diversion. Sixmo is formulated as a diversion and abuse deterrent formulation. Nevertheless, it is possible to extract the buprenorphine from the Sixmo implant. These risks and the patient’s stability in treatment for opioid dependence should be considered when determining whether Sixmo is appropriate for the patient.

Abuse of buprenorphine poses a risk of overdose and death. This risk is increased with the concomitant abuse of buprenorphine and alcohol and other substances, especially benzodiazepines. All patients receiving Sixmo should be monitored for conditions indicative of diversion, or progression of opioid dependence and addictive behaviours suggesting the need for more intensive and structured treatment for substance use.

### Dependence

Buprenorphine is a partial agonist at the  $\mu$  (mu)-opioid receptor and chronic administration produces dependence of the opioid type. Studies in animals, as well as clinical experience, have demonstrated that buprenorphine may produce dependence, but at a lower level than a full agonist, e.g. morphine.

If Sixmo implants are not immediately replaced upon removal, patients should be maintained on sublingual buprenorphine (2 to 8 mg/day), as clinically indicated, until Sixmo treatment is resumed. Patients who elect to discontinue Sixmo treatment should be monitored for withdrawal syndrome, with consideration given to use of a tapering dose of sublingual buprenorphine.

### Precipitation of opioid withdrawal syndrome

The partial opioid agonist properties of buprenorphine may precipitate opioid withdrawal signs and symptoms in persons who are currently physically dependent on full opioid agonists - such as heroin, morphine, or methadone - before the effects of the full opioid agonist have subsided. Verify that patients have completed an appropriate induction period with sublingual buprenorphine or buprenorphine/naloxone, or are already clinically stable on buprenorphine or buprenorphine/naloxone before inserting Sixmo implants (see section 4.2).

### Respiratory and central nervous system (CNS) depression

A number of cases of death due to respiratory depression have been reported while on buprenorphine, particularly when buprenorphine was used in combination with benzodiazepines (see section 4.5) or when buprenorphine was not used according to prescribing information. Deaths have also been reported in association with concomitant administration of buprenorphine and other depressants such as alcohol or other opioids. If buprenorphine is administered to some non-opioid dependent individuals, who are not tolerant to the effects of opioids, potentially fatal respiratory depression may occur.

This product should be used with caution in patients with asthma or respiratory insufficiency (e.g. chronic obstructive pulmonary disease, cor pulmonale, decreased respiratory reserve, hypoxia,

hypercapnia, pre-existing respiratory depression or kyphoscoliosis [curvature of spine leading to potential shortness of breath]).

Buprenorphine may cause drowsiness, particularly when taken together with alcohol or CNS depressants (such as tranquilisers, sedatives or hypnotics) (see section 4.5).

Prior to initiating Sixmo therapy, the patient's medical and treatment history, including use of non-opioid psychoactive substances, needs to be reviewed, in order to ensure that Sixmo treatment can be safely initiated.

### Hepatitis and hepatic events

Cases of acute hepatic injury (including fatal cases) have been reported with the active substance buprenorphine in opioid-dependent addicts both in clinical trials and in post marketing adverse reaction reports. The spectrum of abnormalities ranges from transient asymptomatic elevations in hepatic transaminases to case reports of hepatic failure, hepatic necrosis, hepatorenal syndrome, hepatic encephalopathy and death. In many cases the presence of pre-existing hepatic impairment (genetic disease, liver enzyme abnormalities, infection with hepatitis B or hepatitis C virus, alcohol abuse, anorexia, concomitant use of other potentially hepatotoxic medicines) and ongoing injecting drug use may have a causative or contributory role. These underlying factors including confirmation of viral hepatitis status must be taken into consideration before prescribing Sixmo and during treatment. When a hepatic event is suspected, liver function evaluation is required, including consideration whether to discontinue treatment with Sixmo. If the treatment is continued, hepatic function should be monitored closely.

### Hepatic impairment

Buprenorphine is extensively metabolized in the liver. In a pharmacokinetic study with sublingual buprenorphine, buprenorphine plasma levels were found to be higher and the half-life was found to be longer in patients with moderate and severe hepatic impairment, but not in patients with mild hepatic impairment (see section 5.2). Patients with mild to moderate hepatic impairment should be monitored for signs and symptoms of toxicity, or overdose caused by increased levels of buprenorphine (see section 4.2).

### Treatment of acute pain during Sixmo therapy

While on Sixmo, situations may arise where patients need acute pain management or anaesthesia. Treat these patients with a non-opioid analgesic whenever possible. Patients requiring opioid therapy for analgesia may be treated with a high-affinity full opioid analgesic under the supervision of a healthcare professional, with particular attention to respiratory function. Higher doses may be required for analgesic effect. Therefore, a higher potential for toxicity exists with opioid administration. If opioid therapy is required as part of anaesthesia, patients should be continuously monitored in an anaesthesia care setting by persons not involved in the conduct of the surgical or diagnostic procedure. The opioid therapy must be provided by healthcare professionals trained in the use of anaesthetic medicinal products and the management of the respiratory effects of potent opioids, specifically the establishment and maintenance of a patent airway and assisted ventilation.

### Renal impairment

Renal elimination may be prolonged since 30% of the administered dose is eliminated by the renal route. Metabolites of buprenorphine accumulate in patients with renal failure. Caution is recommended when dosing patients with severe renal impairment (creatinine clearance < 30 mL/min) (see sections 4.2 and 5.2).

### CYP3A inhibitors

Medicines that inhibit the enzyme CYP3A4 may give rise to increased concentrations of buprenorphine. Patients receiving Sixmo should be closely monitored for signs of toxicity if combined with potent CYP3A4 inhibitors (e.g. protease inhibitors like ritonavir, nelfinavir or indinavir, or azole antifungals such as ketoconazole and itraconazole, or macrolide antibiotics). The healthcare professional should review the patient's treatment history for concomitant use of CYP3A4 inhibitors prior to initiating Sixmo treatment to determine suitability (see section 4.5).

### General precautions relevant to the administration of opioids

Opioids may produce orthostatic hypotension in ambulatory patients.

Opioids may elevate cerebrospinal fluid pressure, which may cause seizures, so opioids should be used with caution in patients with head injury, intracranial lesions, other circumstances where cerebrospinal pressure may be increased, or history of seizure.

Opioids should be used with caution in patients with hypotension, prostatic hypertrophy or urethral stenosis.

Opioid-induced miosis, changes in the level of consciousness, or changes in the perception of pain as a symptom of disease may interfere with patient evaluation or obscure the diagnosis or clinical course of concomitant disease.

Opioids should be used with caution in patients with myxoedema, hypothyroidism or adrenal cortical insufficiency (e.g. Addison's disease).

Opioids have been shown to increase intracholedochal pressure, and should be used with caution in patients with dysfunction of the biliary tract.

Opioids should be administered with caution to elderly or debilitated patients.

The concomitant use of monoamine oxidase inhibitors (MAOI) might produce an exaggeration of the effects of opioids, based on experience with morphine (see section 4.5).

### Serotonin syndrome

Concomitant administration of Sixmo and other serotonergic agents, such as MAO inhibitors, selective serotonin re-uptake inhibitors (SSRIs), serotonin norepinephrine re-uptake inhibitors (SNRIs) or tricyclic antidepressants may result in serotonin syndrome, a potentially life-threatening condition (see section 4.5).

If concomitant treatment with other serotonergic agents is clinically warranted, careful observation of the patient is advised, particularly during treatment initiation and dose increases.

Symptoms of serotonin syndrome may include mental-status changes, autonomic instability, neuromuscular abnormalities, and/or gastrointestinal symptoms.

If serotonin syndrome is suspected, a dose reduction or discontinuation of therapy should be considered depending on the severity of the symptoms.

### Skin

Sixmo should also be administered with caution in patients with a history of connective tissue disease (e.g. scleroderma) or history of recurrent methicillin-resistant *Staphylococcus aureus* infections.

Sixmo is contraindicated in patients with a history of keloid or hypertrophic scar formation at the site where Sixmo would be implanted, as difficulties in retrieving the implant are possible (see section 4.3).

## **4.5 Interaction with other medicinal products and other forms of interaction**

Buprenorphine should not be administered together with:

- Alcoholic drinks or medicines containing alcohol, as alcohol increases the sedative effect of buprenorphine.

Buprenorphine should be used cautiously when co-administered with:

- Benzodiazepines: This combination may result in death due to respiratory depression of central origin. Therefore, dosages must be limited and this combination must be avoided in cases where there is a risk of misuse. Patients should be warned that it is extremely dangerous to self-administer non-prescribed benzodiazepines while taking this product, and should also be cautioned to use benzodiazepines concurrently with this product only as directed by their healthcare professional (see section 4.4).
- Other CNS depressants: Other opioid derivatives (e.g. methadone, analgesics and antitussives), certain antidepressants, sedative H1-receptor antagonists, barbiturates, anxiolytics other than benzodiazepines, neuroleptics, clonidine and related substances: these combinations increase CNS depression. The reduced level of alertness can make driving and using machines hazardous (see section 4.7).
- Opioid analgesics: Adequate analgesia may be difficult to achieve when administering a full opioid agonist in patients receiving buprenorphine. Therefore, the potential to overdose with a full agonist exists, especially when attempting to overcome buprenorphine partial agonist effects, or when buprenorphine plasma levels are declining (see section 4.4).
- Opioid antagonists: naltrexone and nalmefene can block the pharmacological effects of buprenorphine. Co-administration during buprenorphine treatment is contraindicated due to the potentially dangerous interaction that may precipitate a sudden onset of prolonged and intense opioid withdrawal symptoms (see section 4.3).
- CYP3A4 inhibitors and inducers: Buprenorphine is metabolized to norbuprenorphine primarily by CYP3A4; therefore, potential interactions may occur when Sixmo is given concurrently with medicinal products that affect CYP3A4 activity. CYP3A4 inhibitors may inhibit the metabolism of buprenorphine resulting in increased  $C_{max}$  and AUC of buprenorphine and norbuprenorphine. Patients treated with CYP inhibitors (e.g. ritonavir, ketoconazole, itraconazole, troleandomycin, clarithromycin, nelfinavir, nefazodone, verapamil, diltiazem, amiodarone, amprenavir, fosamprenavir, aprepitant, fluconazole, erythromycin and grapefruit juice) should be monitored for signs and symptoms of toxicity or overdose (miosis, lip cyanosis, sedation, bradycardia, hypotension, respiratory depression). In case toxicity or overdose symptoms are observed, the removal of the implants and transition to a medicinal product that allows dose adjustment are required.
- Similarly, inducers of CYP3A4 (e.g. phenobarbital, carbamazepine, phenytoin, rifampin) may have the potential to reduce buprenorphine plasma concentrations because of increased metabolism of buprenorphine to norbuprenorphine.
- Monoamine oxidase inhibitors (MAOI): Possible exacerbation of the effects of opioids, based on experience with morphine.
- Serotonergic medicinal products, such as MAO inhibitors, selective serotonin re-uptake inhibitors (SSRIs), serotonin norepinephrine re-uptake inhibitors (SNRIs) or tricyclic antidepressants as the risk of serotonin syndrome, a potentially life-threatening condition, is increased (see section 4.4).

#### **4.6 Fertility, pregnancy and lactation**

##### Pregnancy

There are no or limited data from the use of buprenorphine in pregnant women. Studies in animals have shown reproductive toxicity (see section 5.3). The potential risk for humans is unknown.

Towards the end of pregnancy buprenorphine may induce respiratory depression in the newborn infant even after a short period of administration. Long-term administration of buprenorphine during the last three months of pregnancy may cause a withdrawal syndrome in the neonate (e.g. hypertonia, neonatal tremor, neonatal agitation, myoclonus or convulsions). The syndrome may be milder and more protracted than that from short acting full  $\mu$ -opioid agonists. The syndrome is generally delayed for several hours to several days after birth. The nature of the syndrome may vary depending upon the mother's drug use history.



Due to the long half-life of buprenorphine, neonatal monitoring for several days should be considered at the end of pregnancy, to prevent the risk of respiratory depression or withdrawal syndrome in neonates.

Due to the inflexibility with regard to dose increases and to the increased dose requirements during pregnancy, Sixmo is not considered to be an optimal treatment choice for pregnant women, therefore treatment with Sixmo should not be started in pregnant women. Sixmo is not recommended during pregnancy and in women of childbearing potential not using contraception. If pregnancy occurs during treatment with Sixmo the benefit to the patient should be weighed against the risk to the foetus. Generally, other buprenorphine treatments/formulations are considered more appropriate in this situation.

#### Breast-feeding

Buprenorphine and its metabolites are excreted in human milk to such an extent that effects on the breastfed newborns/infants are likely. Therefore, breastfeeding should be discontinued during treatment with Sixmo.

#### Fertility

There are no or limited data on effects of buprenorphine on human fertility (see section 5.3).

### **4.7 Effects on ability to drive and use machines**

Buprenorphine can influence the ability to drive and use machines and may impair the mental or physical abilities required for the performance of potentially dangerous tasks such as driving a car or operating machinery. This product may cause dizziness, somnolence or sedation especially at the start of treatment.

Plasma concentrations of buprenorphine after insertion of Sixmo are highest during the first 24 to 48 hours. In particular, patients may experience somnolence for up to one week after subcutaneous insertion; therefore, they should be cautioned about driving or operating hazardous machinery especially during this time period. Before engaging driving or operating hazardous machinery patients should be reasonably certain that Sixmo does not adversely affect their ability to engage in such activities.

### **4.8 Undesirable effects**

#### Summary of the safety profile

The safety of Sixmo was evaluated in five Phase 3 studies (3 double-blind and placebo and/or active-controlled studies, and two open-label extension studies).

Adverse drug reactions were categorized as implant or non-implant adverse reactions. The most frequent non-implant adverse reactions in clinical studies with Sixmo were headache, constipation and insomnia. These are very common or common adverse reactions with buprenorphine.

Implant site related adverse reactions with the current (and commercially used) insertion and removal techniques were reported in 25.9% and 14.1% of patients in the double-blind and extension studies, respectively. Most frequent implant adverse reactions were implant site pain, implant site pruritus, implant site haematoma, implant site haemorrhage, implant site erythema and implant site rash.

#### Tabulated list of adverse reactions

Adverse reactions (implant and non-implant) reported are listed in the following table. These adverse reactions are presented by MedDRA system organ class, preferred term, and frequency. Frequency categories are defined as: very common ( $\geq 1/10$ ); common ( $\geq 1/100$  to  $< 1/10$ ); uncommon ( $\geq 1/1,000$  to  $< 1/100$ ); rare ( $\geq 1/10,000$  to  $< 1/1,000$ ); very rare ( $< 1/10,000$ ), not known (cannot be estimated from the available data).

**Table 1: Adverse reactions reported in clinical studies and from post-marketing data with Sixmo and/or reported with other buprenorphine product**

<b>System organ class</b>	<b>Frequency</b>	<b>Adverse reactions</b>
Infections and infestations	common	viral infection, bronchitis**, infection**, influenza**, pharyngitis**, rhinitis**
	uncommon	cellulitis, skin infection, peritonsillar abscess, rash pustular, urinary tract infection, vulvovaginal mycotic infection, implant site infection*, implant site abscess*
Blood and lymphatic system disorders	uncommon	lymphadenopathy, neutropenia
Metabolism and nutrition disorders	common	decreased appetite
	uncommon	abnormal weight gain, dehydration, increased appetite
Psychiatric disorders	common	insomnia, anxiety, hostility**, nervousness**, paranoia**
	uncommon	depression, libido decreased, sleep disorder, apathy, euphoric mood, orgasmic sensation decreased, restlessness, irritability, drug dependence***, agitation***, thinking abnormal***
Nervous system disorders	common	headache, dizziness, somnolence, hypertonia**, syncope**
	uncommon	hypoesthesia, migraine, depressed level of consciousness, hypersomnia, paraesthesia, tremor
Eye disorders	common	mydriasis**
	uncommon	eye discharge, lacrimal disorder, vision blurred
Cardiac disorders	common	palpitations**
	uncommon	atrial flutter, bradycardia
Vascular disorders	common	hot flush, vasodilatation**, hypertension**
Respiratory, thoracic and mediastinal disorders	common	cough**, dyspnoea**
	uncommon	respiratory depression, yawning
Gastrointestinal disorders	common	constipation, nausea, vomiting, diarrhoea, abdominal pain, gastrointestinal disorder**, tooth disorder**
	uncommon	dry mouth, dyspepsia, flatulence, haematochezia
Skin and subcutaneous tissue disorders	common	hyperhidrosis
	uncommon	cold sweat, dry skin, rash, skin lesion, ecchymosis*
Musculoskeletal and connective disorders	common	bone pain**, myalgia**
	uncommon	muscle spasms, limb discomfort, musculoskeletal pain, neck pain, pain in extremity, temporomandibular joint syndrome, arthralgia***
Renal and urinary disorders	uncommon	urinary hesitation, micturition urgency, pollakisuria
Reproductive system and breast disorders	uncommon	dysmenorrhoea, erectile dysfunction
General disorders and administration site conditions	common	fatigue, chills, asthenia, pain, implant site haematoma*, implant site pain*, implant site pruritus*, implant site haemorrhage*, implant site erythema*, implant site scar*, chest pain**, malaise***, drug withdrawal syndrome***

System organ class	Frequency	Adverse reactions
	uncommon	oedema peripheral, discomfort, face oedema, feeling cold, pyrexia, swelling, implant site oedema*, implant site reaction*, device expulsion*, impaired healing*, implant site paraesthesia*, implant site rash*, scarring *
Investigations	common	alanine aminotransferase increased
	uncommon	aspartate aminotransferase increased, weight decreased, blood lactate dehydrogenase increased, gamma-glutamyl-transferase increased, weight increased, blood alkaline phosphatase decreased, amylase increased, blood bicarbonate increased, blood bilirubin increased, blood cholesterol decreased, blood glucose increased, haematocrit decreased, haemoglobin decreased, lipase increased, lymphocyte count decreased, mean cell haemoglobin increased, mean cell volume abnormal, monocyte count increased, neutrophil count increased, platelet count decreased, red blood cell count decreased
Injury, poisoning and procedural complications	common	procedural pain*, procedural site reaction*
	uncommon	post procedural complication (*), contusion (*), wound dehiscence*, migration of implanted drug***, device breakage***

\* Implant site adverse drug reaction

(\*) Observed as implant and non-implant site adverse drug reaction

\*\* Reported with other approved buprenorphine only medicinal product

\*\*\* Post-marketing data only

### Description of selected adverse reactions

#### *Risk of serious complications of insertion and removal of implants*

Rare but serious complications including nerve damage and migration resulting in embolism and death may result from improper insertion of drug implants (see section 4.4). In the post-marketing setting, 2 cases were reported where Sixmo implants had locally migrated from the insertion site. In 3 patients treated in clinical studies, and in 1 patient treated during post-marketing, implants or fragments could not be located and were, therefore, not removed at the end of the treatment. In clinical studies and from post-marketing data 7 cases of clinically relevant implant breakage (breakage associated with an adverse reaction) were observed.

#### *Risk of expulsion*

Improper insertions or infections may lead to protrusion or expulsion. Few cases of protrusion or expulsion of implants, mainly attributed to improper insertion technique, were reported in clinical studies with Sixmo (see section 4.4).

### Reporting of suspected adverse reactions

Reporting suspected adverse reactions after authorisation of the medicinal product is important. It allows continued monitoring of the benefit/risk balance of the medicinal product. Healthcare professionals are asked to report any suspected adverse reactions via the national reporting system listed in [Appendix V](#).

## 4.9 Overdose

### Symptoms

The manifestations of acute buprenorphine overdose include pinpoint pupils, sedation, hypotension, respiratory depression and death.

### Treatment

Priorities are the re-establishment of a patient and protected airway and institution of assisted ventilation, if needed. Supportive measures (including oxygen, vasopressors) should be employed in the management of circulatory shock and pulmonary oedema as indicated. Cardiac arrest or arrhythmias will require advanced life support techniques.

The opioid antagonist naloxone is a specific antidote to respiratory depression resulting from opioid overdose. Naloxone may be of value for the management of buprenorphine overdose. Higher than normal doses and repeated administration may be necessary.

Healthcare professionals should consider the potential role and contribution of buprenorphine when given in conjunction with other CNS depressant medicinal products, CYP3A4 inhibitors, other opioids and in cases of hepatic impairment when determining whether the implants should be removed (see sections 4.4 and 4.5).

## 5. PHARMACOLOGICAL PROPERTIES

### 5.1 Pharmacodynamic properties

Pharmacotherapeutic group: Other nervous system drugs, Drugs used in opioid dependence, ATC code: N07BC01

#### Mechanism of action

Buprenorphine is an opioid partial agonist/antagonist which binds to the  $\mu$  (mu) and  $\kappa$  (kappa) receptors of the brain. Its activity in opioid maintenance treatment is attributed to its slowly reversible properties at the  $\mu$  receptors which, over a prolonged period, minimises the need for use of other opioids.

During clinical pharmacologic studies in opioid-dependent patients, buprenorphine shows ceiling effects on a number of PD and safety parameters. It has a relatively wide therapeutic window as a consequence of its partial agonist/antagonist properties, which attenuates suppression of cardiovascular and respiratory function.

#### Clinical efficacy and safety with Sixmo

The safety and efficacy of Sixmo was investigated in 3 double-blind Phase 3 clinical studies in which a total of 309 patients were treated with Sixmo for up to 6 months (1 implant cycle). Of these 309 patients, 107 patients were treated for an additional 6 months in extension studies (i.e. for 2 implant cycles).

The demonstration of efficacy relies primarily on study PRO-814, a randomized, double-blind and active-controlled Phase 3 study in adult patients who met DSM-IV-TR criteria for opioid dependence and who were clinically stabilised on sublingual buprenorphine. In this study, approximately 75% of patients reported prescription opioids as the primary opioid of abuse, and 21% of patients reported heroin as the primary opioid of abuse. The implant time was 24 weeks. This study enrolled 84 patients in the Sixmo group and 89 patients in the sublingual buprenorphine group, with a median age (range) of 36 (21 to 63) years and 37 (22 to 64) years in the Sixmo and sublingual buprenorphine groups, respectively. In this double-blind and double-dummy study, patients maintained on doses of sublingual buprenorphine of 8 mg/day or less were transferred to 4 Sixmo implants (and daily sublingual

placebo), or sublingual buprenorphine 8 mg/day or less (and 4 placebo implants). The primary endpoint was proportion of responders, defined as patients with no more than 2 of 6 months with evidence of illicit opioid use based on a composite of both urine and self-report results. This endpoint was considered to be of clinical relevance in the targeted indication. Sixmo was shown to be non-inferior to sublingual buprenorphine, the proportion of responders being 87.6% in the sublingual buprenorphine and 96.4% in the Sixmo group. Furthermore, after establishment of non-inferiority, superiority of Sixmo over sublingual buprenorphine was tested and established ( $p=0.034$ ). Retention in treatment was high, with 96.4% of Sixmo patients and 94.4% of sublingual buprenorphine patients completing the study.

Two additional randomised, double-blind, placebo-controlled Phase 3 studies provide supportive data on efficacy and PK (Studies PRO-805 and PRO-806). In both studies adult patients with opioid dependence who were new entrants to buprenorphine treatment were treated over 24 weeks with 4 Sixmo or 4 placebo implants. Patients not adequately treated with the 4 implant dose could receive a fifth implant. Study PRO-806 included an open-label comparator arm with sublingual buprenorphine (12 to 16 mg/day). Patients in all groups were allowed to use supplemental sublingual buprenorphine to control potential withdrawal symptoms/cravings according to pre-specified criteria. Patient characteristics in these studies are shown below.

**Table 2: Patient characteristics in the studies PRO-805 and PRO-806**

	Study PRO-805		Study PRO-806		
	Sixmo N=108	Placebo N=55	Sixmo N=114	Placebo N=54	sublingual buprenorphine N=119
<b>Median age (range), years</b>	33 (19 - 62)	39 (20 - 61)	36 (19 - 60)	33 (19 - 59)	32 (18 - 60)
<b>Primary opioid of abuse, n (%)</b>					
Heroin	69 (63.9%)	34 (61.8%)	76 (66.7%)	28 (51.9%)	75 (63.0%)
Prescription opioids	39 (36.1%)	21 (38.2%)	38 (33.3%)	26 (48.1%)	43 (36.1%)*

\* For 1 patient (0.8%) primary opioid of abuse was "other".

The primary efficacy endpoint in both studies was the cumulative distribution function (CDF) of the percentage of urine samples that were negative for illicit opioids (as evaluated through thrice weekly urine toxicology and patient self-reported opioid use).

In study PRO-805, the primary endpoint was the CDF of the percentage of urine samples that were negative for illicit opioids over weeks 1 to 16, while the CDF over weeks 17 to 24 was evaluated as secondary endpoint.

**Table 3: Percentage of Opioid-Negative Urine Samples for Weeks 1 to 16 and Weeks 17 to 24, Study PRO-805 (ITT)**

Percentage of negative results	Sixmo N=108	Placebo N=55
<b>Weeks 1 to 16</b>		
Mean (SE)	40.4 (3.15)	28.3 (3.97)
CI of mean	34.18, 46.68	20.33, 36.26
Median (Range)	40.7 (0, 98)	20.8 (0, 92)
<b>Weeks 17 to 24</b>		
Mean (SE)	29.0 (3.34)	10.7 (3.19)
CI of mean	22.41, 35.66	4.33, 17.12
Median (Range)	4.4 (0, 100)	0.0 (0, 92)

CI=confidence interval, ITT=intent-to-treat, N=number of subjects, SE=standard error

In the analysis of the CDF (weeks 1 to 16), a statistically significant difference between treatments ( $p=0.0361$ ) was seen, which was in favour of Sixmo.

**Figure 1: Cumulative Distribution Function of the Percentage of Urine Samples Negative for Opioids in Weeks 1-16, Study PRO-805 (ITT)**

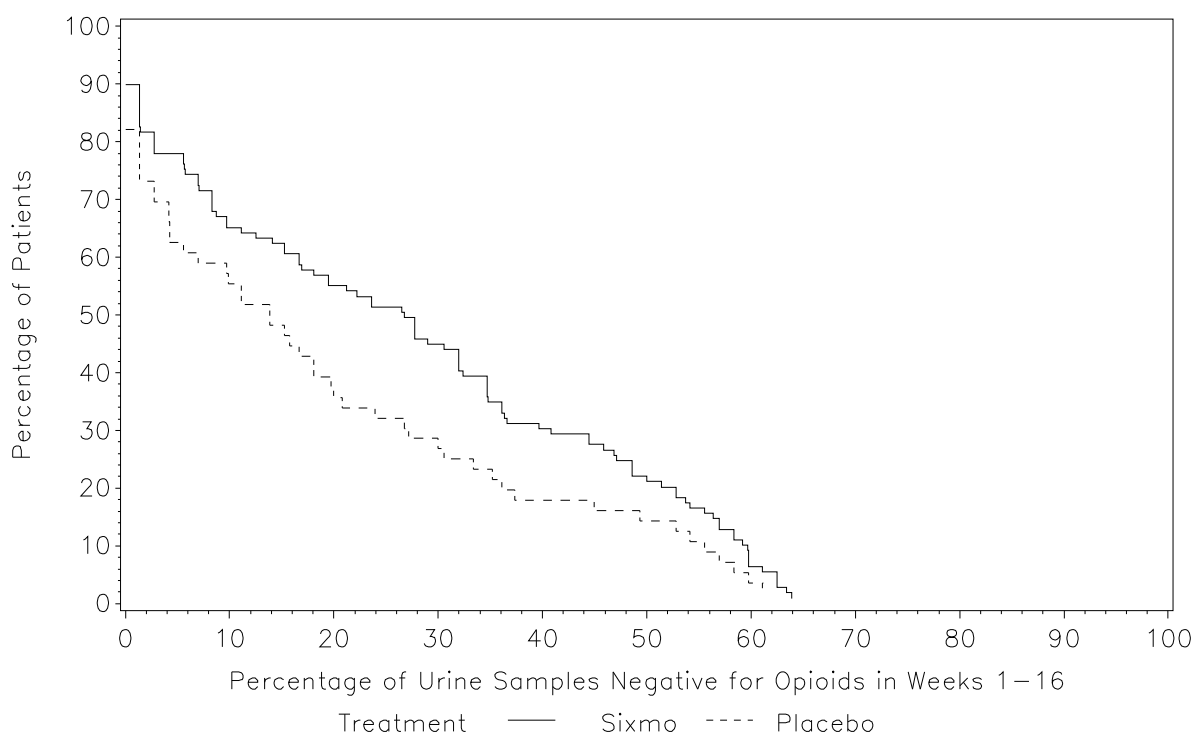

ITT=intent-to-treat

Buprenorphine was not included in urine toxicology assessments.

Study PRO-806 had two co-primary endpoints, which were the CDF of the percentage of urine samples that were negative for illicit opioids for Weeks 1 to 24 in the Sixmo and placebo groups (co-primary 1), and the CDF of the percentage of urine samples that were negative for illicit opioids for Weeks 1 to 24 in the Sixmo and placebo groups, with imputation based on illicit drug self-report data (co-primary 2).

**Table 4: Percentage of Opioid-Negative Urine Samples for Weeks 1 to 24, Study PRO-806 (ITT)**

Percentage of negative results	Sixmo N=114	Placebo N=54	Sublingual buprenorphine N=119
Mean (SE)	31.21 (2.968)	13.41 (2.562)	33.48 (3.103)
CI of mean	25.33, 37.09	8.27, 18.55	27.33, 39.62
Median (Range)	20.28 (0.0, 98.6)	9.03 (0.0, 97.3)	16.33 (0.0, 98.6)

CI=confidence interval, ITT=intent-to-treat, N=number of subjects, SE=standard error

In the analysis of the CDF (co-primary endpoint 1), a statistically significant difference between treatments ( $p<0.0001$ ) was seen, which was in favour of Sixmo.

**Figure 2: Cumulative Distribution Function of the Percentage of Urine Samples Negative for Opioids in Weeks 1-24 (co-primary endpoint 1), Study PRO-806 (ITT Population)**

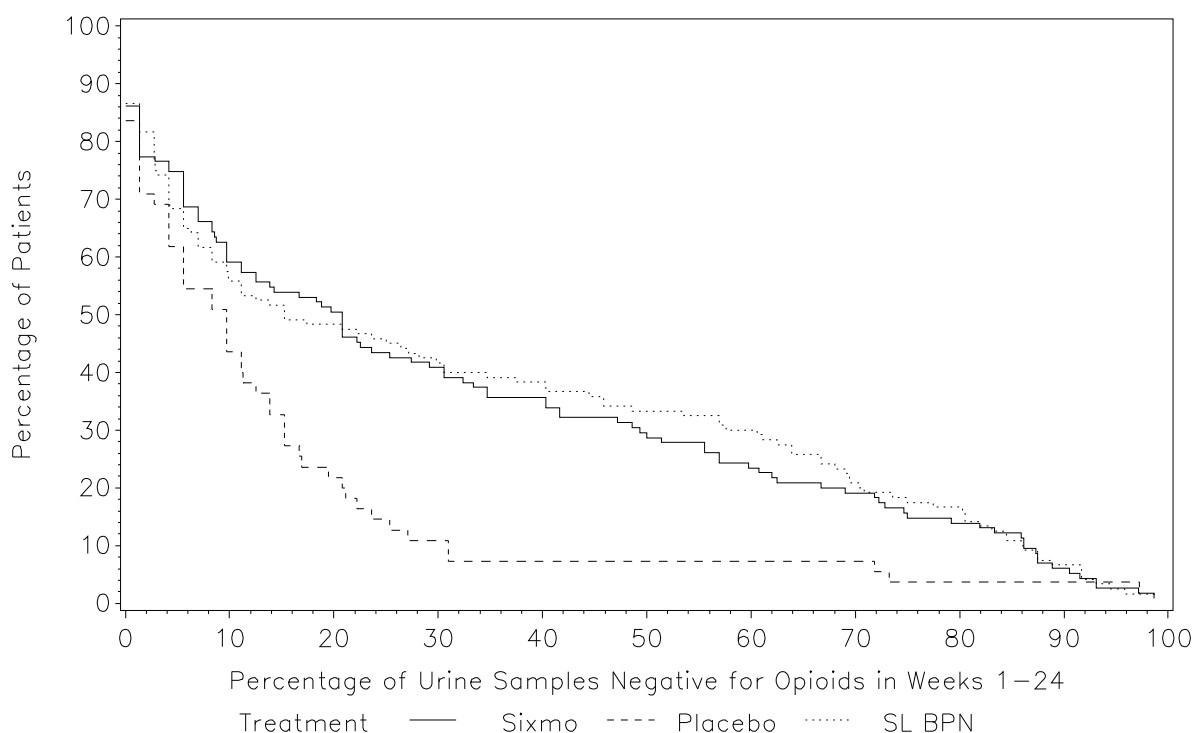

ITT=intent-to-treat, SL BPN = sublingual buprenorphine  
 Buprenorphine was not included in urine toxicology assessments.

The CDF results for co-primary endpoint 2 were fundamentally the same as for endpoint 1 ( $p < 0.0001$ ).

A key secondary endpoint in Study PRO-806 was the difference in proportions of urine samples that were negative for opioids over 24 weeks for Sixmo versus sublingual buprenorphine. Despite the use of an open-label comparator arm, this endpoint is considered robust, as it is based on urine toxicology. In this analysis, the percentage of opioid negative urines in the sublingual buprenorphine group was very similar to the results in the Sixmo group (33% versus 31%), and non-inferiority of Sixmo to sublingual buprenorphine was shown.

In Studies PRO-805 and PRO-806, 62.0% and 39.5% of Sixmo-treated subjects required supplemental SL buprenorphine. The mean doses per week in Sixmo subjects in PRO-805 and PRO-806 studies were 5.16 mg and 3.16 mg, with relatively low mean days of use per week of 0.45 and 0.31, respectively. In each of the two studies, the proportion of subjects requiring supplemental SL BPN was significantly higher in the placebo group than in the Sixmo group (90.9% and 66.7% of subjects, with mean days of use per week of 2.17 and 1.27, in PRO-805 and PRO-806, respectively).

Retention in treatment was high in the Sixmo groups, with 65.7% and 64.0% of patients completing studies PRO-805 and PRO-806, respectively.

The majority of patients (around 80%) in both studies were adequately treated with 4 implants; around 20% of patients required a dose increase with a fifth implant.

In a subset of patients, Sixmo implants broke during implant removal. Breakage rates decreased in studies using the current technique and training. Generally, breakage was not perceived as a safety concern to the patient by the investigator.

**Table 5: Implant breakage in Sixmo double-blind Phase 3 studies**

	Current technique and training		
	PRO-806	PRO-811	PRO-814
	Sixmo N= 99	Sixmo N=78	Sixmo N=82
<b>Number (%) of broken implants</b>	71 (17.0%)	81 (25.0%)	35 (10.7%)
<b>Number (%) of patients with broken implant(s)</b>	42 (42.4%)	38 (48.7%)	22 (26.8%)

N=number of patients with data available.

#### Non-Caucasian population

The clinical experience with Sixmo in non-Caucasian patients is currently limited.

#### Paediatric population

The European Medicines Agency has waived the obligation to submit the results of studies with Sixmo in all subsets of the paediatric population for the maintenance treatment of opioid dependence (see section 4.2 for information on paediatric use).

## **5.2 Pharmacokinetic properties**

### Absorption

The Sixmo PK was assessed in opioid-dependent patients treated with Sixmo in studies TTP-400-02-01, PRO-810, PRO-805, PRO-806, PRO-807 and PRO-811. Prior to entry into acute studies PRO-805, PRO-806, PRO-810 and TTP-400-02-01, patients were treatment naïve adults, with moderate to severe opioid dependency. In the majority of patients, heroin was the primary opioid of use. After Sixmo implant insertion, an initial buprenorphine peak was observed and the median  $T_{max}$  occurred at 12 hours after insertion. After the initial buprenorphine peak, the plasma buprenorphine concentrations decreased slowly and steady-state plasma buprenorphine concentrations were reached by approximately week 4. Mean steady-state plasma buprenorphine concentrations were consistent across all clinical studies, at approximately 0.5 to 1 ng/mL (with the 4-implant dose), and were maintained for approximately 20 weeks (week 4 through week 24) in a 24-week treatment period. At steady state, a small decrease in buprenorphine concentrations was also recorded between week 4 and week 24. Generally, concentrations were comparable to the trough buprenorphine concentration of 8 mg per day sublingual buprenorphine.

Plasma buprenorphine concentrations after Sixmo are illustrated in figure 3. Mean plasma buprenorphine concentrations up to day 28 are based on data from the relative bioavailability study PRO-810 (which had intensive PK sampling), while concentrations after day 28 are based on pooled data from studies PRO-805, PRO-806, PRO-807 and PRO-811.



**Figure 3: Plasma buprenorphine concentrations after insertion of Sixmo (concentrations up to day 28 are based on study PRO-810, while concentrations after day 28 are based on studies PRO-805, PRO-806, PRO-807 and PRO-811)**

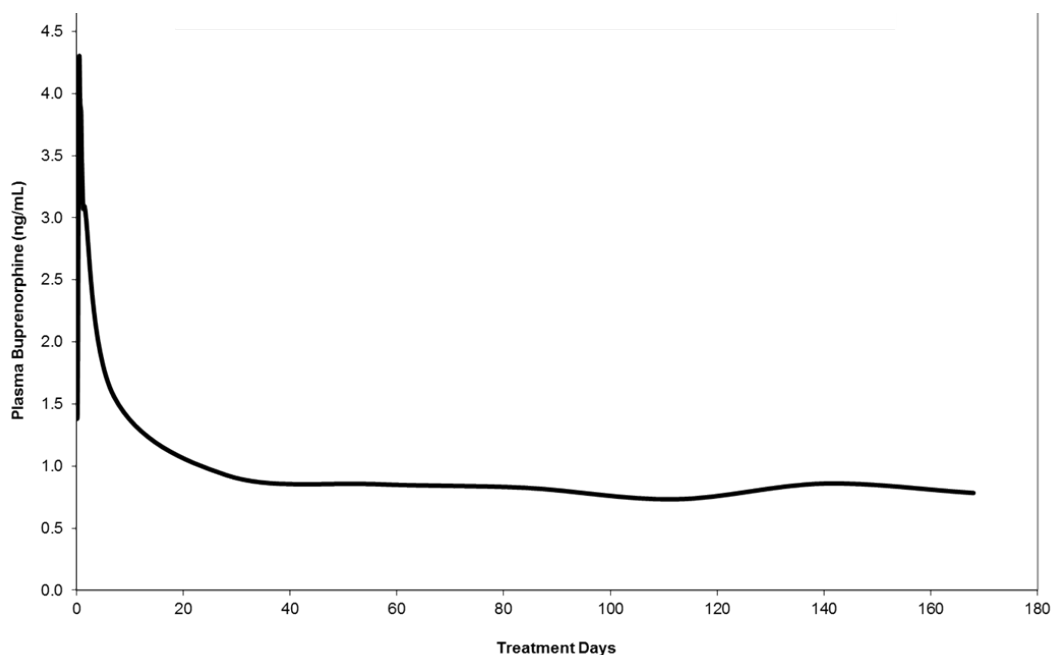

### Distribution

Buprenorphine is approximately 96% protein bound, primarily to alpha and beta globulin.

### Biotransformation

Buprenorphine undergoes N-dealkylation to its major pharmacologically active metabolite norbuprenorphine and subsequent glucuronidation. The formation of norbuprenorphine was initially found to be performed by CYP3A4; subsequent studies also demonstrated the involvement of CYP2C8. Both buprenorphine and norbuprenorphine can further undergo glucuronidation by UDP-glucuronosyltransferases.

### Elimination

A mass balance study of buprenorphine showed complete recovery of radiolabel in urine (30%) and faeces (69%) collected up to 11 days after dosing. Almost all of the dose was accounted for in terms of buprenorphine, norbuprenorphine, and two unidentified buprenorphine metabolites. In urine, most of the buprenorphine and norbuprenorphine was conjugated (buprenorphine: 1% free and 9.4% conjugated; norbuprenorphine: 2.7% free and 11% conjugated). In faeces, almost all of the buprenorphine and norbuprenorphine were free (buprenorphine: 33% free and 5% conjugated; norbuprenorphine: 21% free and 2% conjugated).

Buprenorphine has a mean elimination half-life from plasma ranging from 24 to 48 hours.

### Special populations

#### *Hepatic impairment*

The effect of hepatic impairment on the pharmacokinetics of Sixmo has not been studied. Buprenorphine is extensively metabolized in the liver and increased plasma levels were found to be increased in patients with moderate and severe hepatic impairment. Sixmo is contraindicated in patients with severe hepatic impairment.

### *Renal impairment*

Renal elimination plays a relatively small role (approximately 30%) in the overall clearance of buprenorphine and buprenorphine plasma concentrations were not increased in patients with renal impairment. No Sixmo dose adjustment is therefore considered necessary for patients with renal impairment.

### *Elderly*

Clinical studies of Sixmo did not include patients over 65 years; therefore, the use of the product in this population is not recommended. The efficacy and safety of buprenorphine in elderly patients > 65 years has not been established.

## **5.3 Preclinical safety data**

A standard battery of genotoxicity tests conducted on extracts of Sixmo and ethylene vinyl acetate (EVA) placebo implants was negative. Literature data indicated no genotoxic properties of buprenorphine.

There is no suspicion of carcinogenicity based on the clinical use of buprenorphine.

No published information is available regarding a potential effect of buprenorphine on male and female fertility. Studies in animals have shown reproductive toxicity.

When pregnant rats were exposed to buprenorphine through osmotic minipumps from gestation day 7 onwards, maternal food and water consumption was reduced on gestation days 7 to 20. The mortality index was significantly increased in the buprenorphine groups. There was a greater occurrence of resorptions and an increase in the number of stillbirths. Pups born tended to weigh less on postnatal day 1 compared with controls. Pups exposed to buprenorphine only during the prenatal period had a similar body weight compared with controls in the first 3 postnatal weeks. However, pups exposed to opioids postnatally exhibited significant body weights reductions. Maternal exposure to buprenorphine increased perinatal mortality and caused a delay in some development milestones in neonatal rats.

## **6. PHARMACEUTICAL PARTICULARS**

### **6.1 List of excipients**

Ethylene vinyl acetate copolymer

### **6.2 Incompatibilities**

Not applicable.

### **6.3 Shelf life**

4 years.

### **6.4 Special precautions for storage**

This medicinal product does not require any special storage conditions.

### **6.5 Nature and contents of container**

Each Sixmo implant is packaged individually into a PET/LDPE/Alu/LDPE-peelable foil laminate sachet.

Implant kit: 4 Sixmo implants with 1 applicator

## **6.6 Special precautions for disposal**

The removed implant contains a significant amount of residual buprenorphine.  
Any unused medicinal product or waste material should be disposed of in accordance with local requirements.

## **7. MARKETING AUTHORISATION HOLDER**

L. Molteni & C. dei F.lli Alitti Soc.Es.S.p.A,  
Strada Statale 67,  
50018 Scandicci (Firenze),  
Italy

## **8. MARKETING AUTHORISATION NUMBER(S)**

EU/1/19/1369/001

## **9. DATE OF FIRST AUTHORISATION/RENEWAL OF THE AUTHORISATION**

20 June 2019

## **10. DATE OF REVISION OF THE TEXT**

Detailed information on this medicinal product is available on the website of the European Medicines Agency <http://www.ema.europa.eu>.

## **ANNEX II**

- A. MANUFACTURER(S) OF THE BIOLOGICAL ACTIVE SUBSTANCE(S) AND MANUFACTURER(S) RESPONSIBLE FOR BATCH RELEASE**
- B. CONDITIONS OR RESTRICTIONS REGARDING SUPPLY AND USE**
- C. OTHER CONDITIONS AND REQUIREMENTS OF THE MARKETING AUTHORISATION**
- D. CONDITIONS OR RESTRICTIONS WITH REGARD TO THE SAFE AND EFFECTIVE USE OF THE MEDICINAL PRODUCT**

**A. MANUFACTURER(S) OF THE BIOLOGICAL ACTIVE SUBSTANCE(S) AND MANUFACTURER(S) RESPONSIBLE FOR BATCH RELEASE**

Name and address of the manufacturer of the active substance

TEVA Czech Industries s.r.o.  
Ostravska 29/305  
747 70 Opava, Komarov  
CZECH REPUBLIC

Name and address of the manufacturer(s) responsible for batch release

L. Molteni & C. dei Fratelli Alitti Societa di Esercizio S.p.A.  
Strada Statale 67  
Tosco Romagnola  
Firenze  
50018  
Scandicci  
ITALY

**B. CONDITIONS OR RESTRICTIONS REGARDING SUPPLY AND USE**

Medicinal product subject to special and restricted medical prescription.

**C. OTHER CONDITIONS AND REQUIREMENTS OF THE MARKETING AUTHORISATION**

• **Periodic safety update reports**

The requirements for submission of periodic safety update reports for this medicinal product are set out in the list of Union reference dates (EURD list) provided for under Article 107c(7) of Directive 2001/83/EC and any subsequent updates published on the European medicines web-portal.

The marketing authorisation holder shall submit the first periodic safety update report for this product within 6 months following authorisation.

**D. CONDITIONS OR RESTRICTIONS WITH REGARD TO THE SAFE AND EFFECTIVE USE OF THE MEDICINAL PRODUCT**

• **Risk Management Plan (RMP)**

The MAH shall perform the required pharmacovigilance activities and interventions detailed in the agreed RMP presented in Module 1.8.2 of the marketing authorisation and any agreed subsequent updates of the RMP.

An updated RMP should be submitted:

- At the request of the European Medicines Agency;
- Whenever the risk management system is modified, especially as the result of new information being received that may lead to a significant change to the benefit/risk profile or as the result of an important (pharmacovigilance or risk minimisation) milestone being reached.

- **Additional risk minimisation measures**

Prior to the launch of SIXMO in each Member State (MS), the Marketing Authorisation Holder (MAH) must agree the content and format of the educational materials, including communication media, distribution modalities, and any other aspects of the programme, with the National Competent Authority (NCA).

The MAH shall ensure that in each MS where SIXMO is marketed, all physicians expected to insert / remove SIXMO subcutaneous (SC) implant are provided with an educational programme, aiming at preventing / minimising the important identified risk of implant protrusion / (spontaneous) expulsion, the important potential risks of damage to nerves or blood vessels during insertion / removal procedure, (dislocation and) migration / missing (partial) implant.

The physician educational programme, provided in conjunction with the Summary of Product Characteristics (SmPC), should include lecture slides and a detailed, face to face, step-by step description and live demonstration of the surgical procedure for SIXMO insertion and removal. Physicians should also be informed about risks and complications of this procedure (i.e. implant migration, protrusion, expulsion, and nerve damage).

The MAH shall also ensure that in each MS where SIXMO is marketed, each patient being prescribed this SC implant receives from the treating physician the Patient Information Leaflet (PIL) and a (wallet-sized) patient alert card, to be carried out at all times while on SIXMO treatment, and presented to other health care professionals (HCP) before any medical treatment / intervention is carried out. The patient alert card should mention:

- That the card-holder is using SIXMO (buprenorphine only opioid-dependence treatment via SC implant located at the inner side of the upper arm)
- Implant insertion and six-month removal date(s)
- Name and contact details of the treating physician
- The safety concerns associated with SIXMO therapy (i.e. potential life-threatening interactions with other, concomitant therapies)

- **Obligation to conduct post-authorisation measures**

The MAH shall complete, within the stated timeframe, the below measures:

Description	Due date
MOLTeNI-2019-01 - A prospective, observational (non-interventional), post-authorisation safety cohort study to evaluate the incidence of the breakages and insertion/removal complications of buprenorphine implants (Sixmo) in the routine clinical care	Q2 2024

**ANNEX III**  
**LABELLING AND PACKAGE LEAFLET**

## **A. LABELLING**



**PARTICULARS TO APPEAR ON THE OUTER PACKAGING**

**Outer carton (kit)**

**1. NAME OF THE MEDICINAL PRODUCT**

Sixmo 74.2 mg implant  
buprenorphine

**2. STATEMENT OF ACTIVE SUBSTANCE(S)**

Each implant contains buprenorphine hydrochloride equivalent to 74.2 mg of buprenorphine.

**3. LIST OF EXCIPIENTS**

Excipient: Ethylene vinyl acetate copolymer

**4. PHARMACEUTICAL FORM AND CONTENTS**

4 implants  
1 single use applicator

**5. METHOD AND ROUTE(S) OF ADMINISTRATION**

Read the package leaflet before use.  
Subcutaneous use

**6. SPECIAL WARNING THAT THE MEDICINAL PRODUCT MUST BE STORED OUT OF THE SIGHT AND REACH OF CHILDREN**

Keep out of the sight and reach of children.

**7. OTHER SPECIAL WARNING(S), IF NECESSARY**

**8. EXPIRY DATE**

EXP

**9. SPECIAL STORAGE CONDITIONS**

**10. SPECIAL PRECAUTIONS FOR DISPOSAL OF UNUSED MEDICINAL PRODUCTS OR WASTE MATERIALS DERIVED FROM SUCH MEDICINAL PRODUCTS, IF APPROPRIATE**

Dispose of in accordance with local requirements.

**11. NAME AND ADDRESS OF THE MARKETING AUTHORISATION HOLDER**

L. Molteni & C. dei F.lli Alitti Soc.Es.S.p.A,  
Strada Statale 67,  
50018 Scandicci (Firenze),  
Italy

**12. MARKETING AUTHORISATION NUMBER(S)**

EU/1/19/1369/001

**13. BATCH NUMBER**

Lot

**14. GENERAL CLASSIFICATION FOR SUPPLY**

Medicinal product subject to medical prescription.

**15. INSTRUCTIONS ON USE**

**16. INFORMATION IN BRAILLE**

Justification for not including Braille accepted.

**17. UNIQUE IDENTIFIER – 2D BARCODE**

2D barcode carrying the unique identifier included.

**18. UNIQUE IDENTIFIER - HUMAN READABLE DATA**

PC:

SN:

NN:

**PARTICULARS TO APPEAR ON THE IMMEDIATE PACKAGING**

Sachet

**1. NAME OF THE MEDICINAL PRODUCT**

Sixmo 74.2 mg implant  
buprenorphine

**2. STATEMENT OF ACTIVE SUBSTANCE(S)**

Each implant contains buprenorphine hydrochloride equivalent to 74.2 mg of buprenorphine.

**3. LIST OF EXCIPIENTS**

Excipient: Ethylene vinyl acetate copolymer

**4. PHARMACEUTICAL FORM AND CONTENTS**

1 implant

**5. METHOD AND ROUTE(S) OF ADMINISTRATION**

Read the package leaflet before use.  
Subcutaneous use

**6. SPECIAL WARNING THAT THE MEDICINAL PRODUCT MUST BE STORED OUT OF THE SIGHT AND REACH OF CHILDREN**

Keep out of the sight and reach of children.

**7. OTHER SPECIAL WARNING(S), IF NECESSARY**

**8. EXPIRY DATE**

EXP

**9. SPECIAL STORAGE CONDITIONS**

**10. SPECIAL PRECAUTIONS FOR DISPOSAL OF UNUSED MEDICINAL PRODUCTS OR WASTE MATERIALS DERIVED FROM SUCH MEDICINAL PRODUCTS, IF APPROPRIATE**

Dispose of in accordance with local requirements.

**11. NAME AND ADDRESS OF THE MARKETING AUTHORISATION HOLDER**

L. Molteni & C. dei F.lli Alitti Soc.Es.S.p.A,  
Strada Statale 67,  
50018 Scandicci (Firenze),  
Italy

**12. MARKETING AUTHORISATION NUMBER(S)**

EU/1/19/1369/001

**13. BATCH NUMBER**

Lot

**14. GENERAL CLASSIFICATION FOR SUPPLY**

Medicinal product subject to medical prescription.

**15. INSTRUCTIONS ON USE**

**16. INFORMATION IN BRAILLE**

Justification for not including Braille accepted.

**17. UNIQUE IDENTIFIER – 2D BARCODE**

**18. UNIQUE IDENTIFIER - HUMAN READABLE DATA**

**PATIENT ALERT CARD**

## Patient Alert Card

- The holder of this card uses a buprenorphine only opioid dependence treatment called Sixmo.
- Implants are located under the skin, at the inner side of the upper arm.
- Always keep this card with you while on treatment.
- Present this card to your doctor, dentist or surgeon before any medical treatment or surgery.
- Contact your doctor if you experience any unusual symptoms, such as breathing problems, head injury, increased pressure in the head.

**1. NAME OF THE MEDICINAL PRODUCT**

Sixmo 74.2 mg implant  
(buprenorphine)

**2. NAME OF THE MARKETING AUTHORISATION HOLDER**

L. Molteni & C. dei F.lli Alitti  
Local representative contact

**3. EXPIRY DATE****4. BATCH NUMBER**

Lot

**5. OTHER**

Treating doctor (name / contact information):

Patient name:

**PROCEDURAL INFORMATION**

Insertion date:

6-month removal date:

Location of implant: (upper arm: left / right)

**IMPORTANT INFORMATION**

Each implant contains buprenorphine hydrochloride equivalent to 74.2 mg of buprenorphine.

**B. PACKAGE LEAFLET**

## Package leaflet: Information for the user

### Sixmo 74.2 mg implant buprenorphine

▼ This medicine is subject to additional monitoring. This will allow quick identification of new safety information. You can help by reporting any side effects you may get. See the end of section 4 for how to report side effects.

**Read all of this leaflet carefully before you start using this medicine because it contains important information for you.**

- Keep this leaflet. You may need to read it again.
- If you have any further questions, ask your doctor or pharmacist.
- If you get any side effects, talk to your doctor or pharmacist. This includes any possible side effects not listed in this leaflet. See section 4.

#### What is in this leaflet

1. What Sixmo is and what it is used for
2. What you need to know before you use Sixmo
3. How to use Sixmo
4. Possible side effects
5. How to store Sixmo
6. Contents of the pack and other information

#### 1. What Sixmo is and what it is used for

Sixmo contains the active substance buprenorphine, which is a type of opioid medicine. It is used to treat opioid dependence in adults who are also receiving medical, social and psychological support.

#### 2. What you need to know before you use Sixmo

##### Do not use Sixmo if you:

- are allergic to buprenorphine or any of the other ingredients of this medicine (listed in section 6)
- have severe breathing problems
- have severely reduced liver function
- have acute alcoholism or alcohol delirium caused by withdrawal from alcohol
- are using naltrexone or nalmefene to treat alcohol or opioid dependence
- have had an increased formation of scar tissue

Patients who may not be investigated using a magnetic resonance imaging (MRI) scan must not be allowed to receive Sixmo.

#### Warnings and precautions

Talk to your doctor before using Sixmo if you have:

- asthma or other breathing problems
- mild or moderate liver problems
- reduced kidney function
- head injury or other circumstances where the pressure in the head may be increased
- a history of fits
- low blood pressure
- enlarged prostate or narrowed urethra

- underactive thyroid
  - reduced adrenal gland function, such as Addison's disease
  - abnormal function of the bile duct
  - general weakness and poor health, or you are elderly
  - a history of connective tissue disease such as scleroderma
  - a history of recurrent methicillin-resistant Staphylococcus aureus infections (MRSA)
  - depression or other conditions that are treated with antidepressants.
- The use of these medicines together with Sixmo can lead to serotonin syndrome, a potentially life-threatening condition (see “Other medicines and Sixmo”).

### **Important aspects to consider during treatment:**

- **Drowsiness** may occur especially in the first week after insertion. See “Driving and using machines”.
- Your doctor should examine the **insertion site** for infections and wound problems:
  - one week after implant insertion and
  - at least once a month thereafter
- **Infection** may occur **at the site of the insertion or removal** of the implant. Excessive touching of the implants or insertion site shortly after insertion may increase the chance of infection. Tell your doctor immediately if you have any signs of infection (such as redness or inflammation) at the site of insertion or removal.
- If an implant comes out after insertion, take the following steps:
  - Schedule an appointment with the inserting doctor as soon as possible.
  - Place the implant in a glass jar with a lid. Store it safely away from others, especially children. Bring it to the inserting doctor to determine whether the full implant has been expelled.

Please note: Buprenorphine can cause severe, possibly fatal, breathing depression (shortness of breath or stops breathing) in children who are accidentally exposed to it.

  - The doctor will monitor you until the implant is replaced to evaluate for withdrawal symptoms.
- Avoid moving implants around under the skin or gain a lot of weight after insertion of Sixmo as this may make it difficult to locate implants.
- **Misuse and abuse:** If buprenorphine is abused it can lead to overdose and death. This risk increases when additionally using alcohol or other substances.
- This medicine can cause **dependence**, but at a lower level than other substances such as morphine. If you stop Sixmo treatment your doctor will monitor you for **withdrawal symptoms**.
- A number of cases of death due to **breathing depression** have been reported while on buprenorphine. Particularly, this occurs when additionally using alcohol, other opioids or certain medicines which calm, induce sleep or relax muscles. Buprenorphine can cause fatal breathing problems in non-dependent people or children.  
Sixmo should be used with caution in patients with asthma or other breathing problems.
- **Liver damage**, including liver failure, has been reported when using buprenorphine. This may be related to existing reduced liver function and ongoing injecting drug use. If liver problems are suspected your doctor will carry out tests to decide if treatment should be stopped.
- While using Sixmo, situations may arise where you need acute **pain treatment** or **anaesthesia**. Ask your doctor or pharmacist for advice in these cases.
- Substances like buprenorphine may cause **pinpoint pupils**, **change consciousness** or the way you **feel pain**.
- Substances like buprenorphine may cause a sudden drop in **blood pressure**, causing dizziness when getting up quickly.

### **Children and adolescents**

Sixmo is not recommended for children under 18 years.

### **Patients over 65 years**



Sixmo is not recommended for patients over 65 years.

### **Other medicines and Sixmo**

Tell your doctor or pharmacist if you are using, have recently used or might use any other medicines.

Especially, **inform your doctor** during Sixmo treatment before using:

- medicines which calm, induce sleep or relax muscles, with active substance names ending with “azepam”  
This combination may result in death due to breathing depression. Therefore, use these medicines during Sixmo treatment only on doctor’s advice and at the prescribed dosage.
- other medicines that depress the brain or spinal cord, as these reduce alertness, making driving and using machines hazardous
  - other opioid derivatives such as methadone, strong painkillers and cough suppressants
  - certain medicines to treat depressions
  - medicines called antihistamines used to treat allergic reactions, sleep disturbances, cold; or prevent and treat nausea and vomiting
  - medicines to treat epilepsy or to sedate, with active substance names mostly ending with “tal”
  - medicines to treat anxiety, other than those described in the first bullet point
  - medicines to treat mental or anxiety disorders, with sedative effects, called neuroleptics
  - clonidine: a medicine to treat high blood pressure and high eye pressure
- naltrexone, nalmefene, used to treat addiction  
They can block the effects of buprenorphine. Do not use these medicines during Sixmo treatment as they can cause a sudden onset of prolonged, intense withdrawal symptoms.
- medicines to treat HIV infections with active substance names ending in “navir”, such as ritonavir, nelfinavir, amprenavir, fosamprenavir
- medicines to treat fungal infections, like thrush, with active substance names ending in “azole”, such as ketoconazole, itraconazole, fluconazole
- clarithromycin, erythromycin, troleandomycin: medicines to treat bacterial infections
- nefazodone: a medicine to treat depression
- verapamil, diltiazem, amiodarone: medicines to treat high blood pressure and heart disorders
- aprepitant: a medicine to prevent nausea and vomiting
- phenobarbital, carbamazepine, phenytoin: medicines to treat epilepsy and other illnesses
- rifampicin: a medicine to treat tuberculosis or certain other infections
- certain medicines to treat depression or Parkinson’s disease, called monoamine oxidase inhibitors, such as phenelzine, isocarboxazid, iproniazid and tranylcypromine
- anti-depressants such as moclobemide, tranylcypromine, citalopram, escitalopram, fluoxetine, fluvoxamine, paroxetine, sertraline, duloxetine, venlafaxine, amitriptyline, doxepine, or trimipramine. These medicines may interact with Sixmo and you may experience symptoms such as involuntary, rhythmic contractions of muscles, including the muscles that control movement of the eye, agitation, hallucinations, coma, excessive sweating, tremor, exaggeration of reflexes, increased muscle tension, body temperature above 38°C. Contact your doctor when experiencing such symptoms.

### **Sixmo with food, drink and alcohol**

Do not drink alcohol during Sixmo treatment, as it increases the sedative effect.

Avoid grapefruit juice to prevent possible side effects.

## **Pregnancy and breast-feeding**

If you are pregnant or breast-feeding, think you may be pregnant or are planning to have a baby, ask your doctor for advice before using this medicine.

- **pregnancy**  
Sixmo is not recommended during pregnancy, nor in women of childbearing age not using contraception.  
When used during pregnancy, particularly late pregnancy, buprenorphine may cause withdrawal symptoms, including breathing problems, in the newborn baby. This may appear several days after birth.
- **breast-feeding**  
Do not breast-feed during Sixmo treatment, as buprenorphine passes into breast milk.

## **Driving and using machines**

Buprenorphine may reduce the ability to drive and use machines; especially during the first 24 to 48 hours up to one week following implant insertion. You may feel dizzy, drowsy and less alert. Do not drive or perform dangerous activities until you are certain Sixmo does not reduce your ability in such activities.

## **3. How to use Sixmo**

Always use this medicine exactly as your doctor has told you. Check with your doctor if you are not sure.

Sixmo implants must be inserted, removed, and patients monitored by a healthcare professional familiar with the procedure, with experience in the management of opioid addiction.

### **Before administering Sixmo implants**

You must be on a stable buprenorphine dose of between 2 to 8 mg per day, given under the tongue. This must be for at least 30 days and to be decided by your doctor.

Buprenorphine given under the tongue will be stopped 12 to 24 hours before insertion of Sixmo implants.

### **Treatment with Sixmo implants**

Each dose consists of **4 implants**.

Before inserting Sixmo, your doctor will give you a local anaesthetic to numb the area. The implants will then be inserted under the skin in the inner side of the upper arm.

After insertion of the implants, the doctor will apply a sterile gauze with a pressure bandage to minimize bruising. You may remove the pressure bandage after 24 hours and the adhesive bandage after five days. Apply an ice pack on the arm for 40 minutes every two hours for the first 24 hours, then as needed.

Your doctor will also give you a Patient Alert Card that provides the

- insertion site and date
  - latest date on which the implant must be removed
- Keep this card in a safe place, since the information on the card may make it easier to carry out removal.

Your doctor will examine the insertion site one week following implant insertion and at a minimum once-monthly thereafter for signs of:

- infection or any problems with wound healing

- evidence of implant coming out of the skin

Please attend all of these necessary appointments. Inform your doctor immediately if you think you have an infection at the implant site or if the implant starts to come out.

If you feel the need for additional buprenorphine doses, contact your doctor straight away.

### **Removal of Sixmo implants**

Sixmo implants are intended to be in place for **6 months** and provide a continuous delivery of buprenorphine. They are removed by the doctor at the end of the sixth month.

The implants should only be removed by a doctor who is familiar with the procedure. If the implants cannot be located, the doctor may use ultrasound or a type of scan called magnetic resonance imaging (MRI).

After removal of the implant, the doctor will apply a sterile gauze with a pressure bandage to minimize bruising. You may remove the pressure bandage after 24 hours and the adhesive bandage after five days. Apply an ice pack on the arm for 40 minutes every two hours for the first 24 hours, then as needed.

### **Retreatment with Sixmo implants**

When the first 6-month treatment period is up, a new set of Sixmo implants may be given after removal of the old implants, preferably on the same day. New implants will be inserted in the other arm.

If another set of implants is not inserted on the same day as the previous set is removed: A dose of between 2 and 8 mg buprenorphine daily, given under the tongue, is recommended until repeat treatment occurs. This should be stopped 12 to 24 hours before insertion of the next set of Sixmo implants.

### **If you have more Sixmo than you need**

In some cases, the dose delivered by the implants might be more than the one you need. Overdose symptoms include:

- pinpoint pupils
- sedation
- low blood pressure
- breathing difficulties, breathing slowly

In the worst case, it can result in breathing stopping, heart failure and death.

Inform your doctor immediately if the above symptoms occur, or go to the nearest hospital and bring this leaflet and your Patient Alert Card with you. Do not attempt to remove the implants by yourself as this could be very dangerous.

If you have any further questions on the use of this medicine, ask your doctor or pharmacist.

## **4. Possible side effects**

Like all medicines, this medicine can cause side effects, although not everybody gets them.

Side effects can occur with the following frequencies:

**Common**, may affect up to 1 in 10 people

- constipation, nausea, vomiting, diarrhoea
- other stomach and bowel disorders, tooth disorder
- pain, such as abdominal pain, bone pain, muscle pain, chest pain, headache

- dizziness, drowsiness
- sleeplessness, anxiety, hostility, nervousness
- mental condition, characterised by delusions and irrationality
- high blood pressure, feeling heartbeat
- fainting
- dilated pupils
- hot flush, bruising, dilation of blood vessels
- drug withdrawal syndrome, such as sweating, feeling hot and cold
- fatigue, chills, weakness, increased muscle tone
- infection, such as viral infection (e.g. flu)
- cough, breathlessness
- inflammation of the airways in the lungs, throat or inner lining of the nose
- increased sweating, feeling unwell
- decreased appetite
- increased level of a liver enzyme, alanine aminotransferase, in blood tests
- reactions at the implant site
  - pain, itching
  - procedural site reaction, such as pain during the insertion procedure
  - bruising, skin reddening, scar
  - bleeding

**Uncommon**, may affect up to 1 in 100 people

- dry mouth, wind, indigestion, bloody stool
- migraine, tremor
- excessive sleepiness
- abnormal sensation such as prickling, “pins and needles”, tingling and itchiness
- reduced consciousness
- sleep disorder, disinterest
- depression, euphoria
- decreased sexual desire, decreased orgasmic sensation
- restlessness, excitement, excitability, abnormal thoughts
- drug dependence
- reduced sense of touch or sensation
- fever, feeling cold, discomfort
- swelling, including tissue swelling in arms, legs or face caused by excess fluid
- muscle spasms, limb discomfort
- pain affecting muscles and skeleton, neck, limbs, joints
- pain and dysfunction of chewing muscles and joints called temporomandibular joint syndrome
- breathing depression, yawning
- cellulitis, skin infection, boil
- tonsil complications
- rash, rash pustular, skin lesion
- cold sweat, dry skin
- small bleeds beneath the skin
- changes in blood levels
  - increased enzyme levels: aspartate aminotransferase, gamma-glutamyltransferase, blood lactate dehydrogenase, lipase, amylase
  - decreased enzyme levels: alkaline phosphatase
  - increased bicarbonate level
  - increased bilirubin level - a yellow breakdown substance of the blood pigment
  - increased glucose level
  - decreased cholesterol level
  - decreased haematocrit - the percentage of blood cells on the blood volume
  - decreased haemoglobin - the red blood cell pigment, increased mean cell haemoglobin
  - increase in certain white blood cell count: monocyte, neutrophils

- decreased cell count: platelets, red blood cells, lymphocytes
- abnormal mean cell volume
- increased or decreased weight, including abnormal weight gain
- dehydration, increased appetite
- painful period, erectile dysfunction
- eye discharge, blurred vision, lacrimal disorder
- slow heartbeat, abnormal heart rhythm that starts in the atrial chambers of the heart
- urinary hesitation, urge to urinate, urinating more frequently with little urinary output
- urinary tract infection
- vulvovaginal fungal infection
- lymph node disease
- lack of a white blood cell type called neutrophils
- complication after the procedure
- migration of implant(s), device breakage or expulsion
- reopening of a closed wound
- reactions at the implant site
  - infection, including wound infection
  - rash, scarring
  - reduced healing
  - swollen area containing pus

### **Reporting of side effects**

If you get any side effects, talk to your doctor or pharmacist. This includes any possible side effects not listed in this leaflet. You can also report side effects directly via [the national reporting system listed in Appendix V](#). By reporting side effects you can help provide more information on the safety of this medicine.

### **5. How to store Sixmo**

Keep this medicine out of the sight and reach of children.

Do not use this medicine after the expiry date which is stated on the label and carton after EXP. The expiry date refers to the last day of that month.

This medicinal product does not require any special storage conditions.

### **6. Contents of the pack and other information**

#### **What Sixmo contains**

- The active substance is buprenorphine.  
Each implant contains buprenorphine hydrochloride equivalent to 74.2 mg of buprenorphine.
- The other ingredient is ethylene vinyl acetate copolymer.

#### **What Sixmo looks like and contents of the pack**

Sixmo is a white/off-white to pale yellow rod-shaped implant, 26.5 mm long and 2.4 mm in diameter.

Sixmo is provided in a carton. It consists of four implants individually packaged into laminated foil sachets and one individually packaged sterile disposable applicator.

## **Marketing Authorisation Holder and Manufacturer**

L. Molteni & C. dei F.lli Alitti Soc.Es.S.p.A,  
Strada Statale 67,  
50018 Scandicci (Firenze),  
Italy

### **This leaflet was last revised in**

Detailed information on this medicine is available on the European Medicines Agency web site:  
<http://www.ema.europa.eu>.

---

### **The following information is intended for healthcare professionals only:**

The insertion and removal of Sixmo should take place in a setting that allows for insertion under aseptic conditions, where the patient is able to lie on their back. It is recommended that the healthcare professional is in a seated position during the entire insertion procedure so that the insertion site and the movement of the needle just under the skin can be clearly seen from the side.

Only a healthcare professional who is trained in the insertion of Sixmo should perform the procedure, using only the implant applicator, with the recommended local anaesthetic available. One applicator is used to insert all four implants. Implants inserted more deeply than subcutaneous (deep insertion) may not be palpable and the localisation and/or removal may be difficult. If the implants are inserted deeply, it is possible that neurovascular injury may occur. For patients returning for subsequent treatment with Sixmo, preparations should be made to perform both the removal and insertion of Sixmo at the same visit. The removed implant contains a significant amount of residual buprenorphine. It must be handled with adequate security and accountability for proper disposal in accordance with local requirements.

### **Key instruction for proper insertion**

The basis for successful use and subsequent removal of Sixmo is a correct and carefully performed subcutaneous insertion of the implants in accordance with the instructions. Properly placed implants are those placed just under the skin, using the implant applicator, about 80 to 100 mm (8 to 10 cm) above the medial epicondyle, in the sulcus between the biceps and triceps muscle of the inner side of the upper arm. The implants should be positioned in a fan-shaped distribution at least 5 mm from the incision, and palpable after placement. The closer the implants lie to each other at the time of insertion, the more easily they can be removed.

### **Equipment for subcutaneous insertion of Sixmo**

The following equipment is needed for implant insertion under aseptic conditions:

- an examination table for the patient to lie on
- instrument stand covered with sterile drape
- adequate lighting, such as headlamp
- sterile fenestrated drape
- latex, talc-free sterile gloves
- alcohol pad
- surgical marker
- antiseptic solution, such as chlorhexidine
- local anaesthetic, such as 1% lidocaine with adrenaline 1:100,000
- 5 mL syringe with 25G×1.5" needle (0.5×38 mm)
- Adson single tooth tissue forceps
- #15 blade scalpel
- thin adhesive strip around 6 mm wide (butterfly strip)

- 100×100 mm sterile gauze
- adhesive bandages
- pressure bandage around 8 cm wide
- liquid adhesive
- 4 Sixmo implants
- 1 implant applicator

The implant applicator (disposable) and its parts are shown in Figure 1.

Figure 1

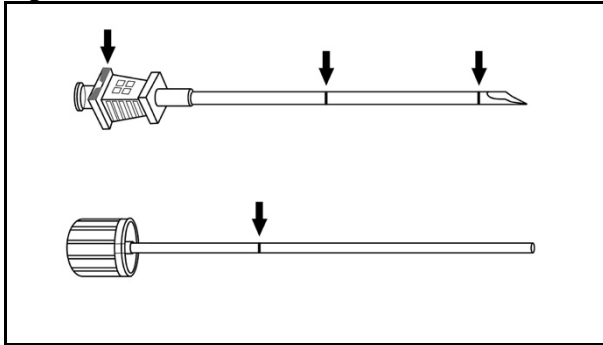

### Instructions for subcutaneous insertion of Sixmo

**Step 1:** The patient should lie on their back, with the intended arm flexed at the elbow and externally rotated, so that the hand is positioned next to the head. Identify the insertion site, which is at the inner side of the upper arm, about 80 to 100 mm (8 to 10 cm) above the medial epicondyle, in the sulcus between the biceps and triceps muscle. Having the patient flex the biceps muscle may facilitate identification of the site (Figure 2).

Figure 2

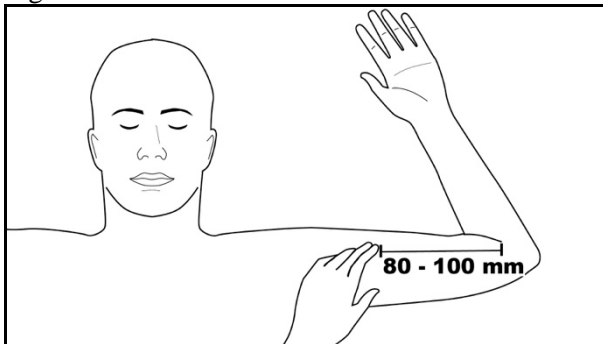

**Step 2:** Clean the insertion site with an alcohol pad. Mark the insertion site with the surgical marker. The implants will be inserted through a small 2.5 to 3 mm subcutaneous incision. Mark the channel tracks where each implant will be inserted by drawing 4 lines - with each line 40 mm long. The implants will be positioned in a close fan-shaped distribution 4 to 6 mm apart, with the fan opening towards the shoulder (Figure 3).

Figure 3

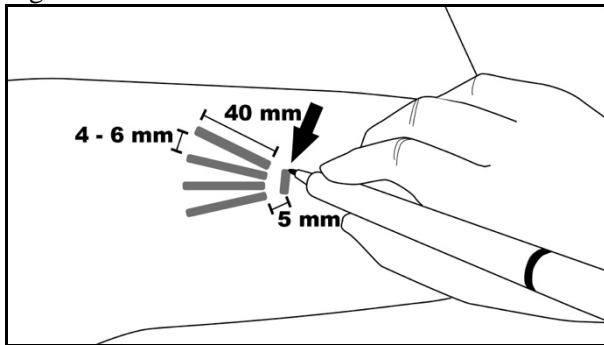

**Step 3:** Put on sterile gloves and check the function of the implant applicator by removing the obturator from the cannula and relocking it. Clean the insertion site with an antiseptic solution, such as chlorhexidine. Do not blot or wipe away.

Apply the sterile fenestrated drape to the patient's arm (Figure 4). Anaesthetise the insertion area at the incision site and just under the skin, along the planned insertion channels, by injecting 5 mL lidocaine 1% with adrenaline 1:100,000. After determining that anaesthesia is adequate and effective, make a shallow incision 2.5 to 3 mm in length at incision site marking.

Figure 4

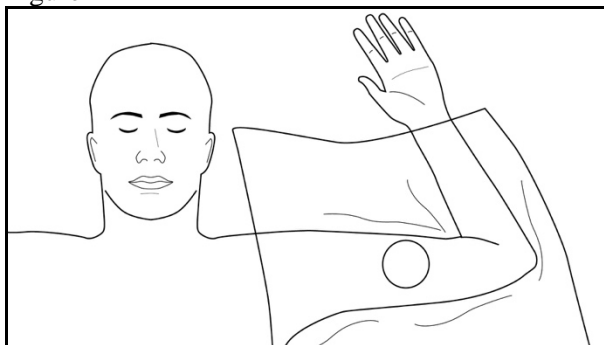

**Step 4:** Lift the edge of the incision opening with the toothed forceps. While applying counter-traction to the skin, at a slight angle (no greater than 20 degrees), insert only the tip of the applicator into the subcutaneous space (depth of 3 to 4 mm below the skin), with the bevel-up stop marking on the cannula facing upwards and visible with the obturator locked fully into the cannula (Figure 5).

Figure 5

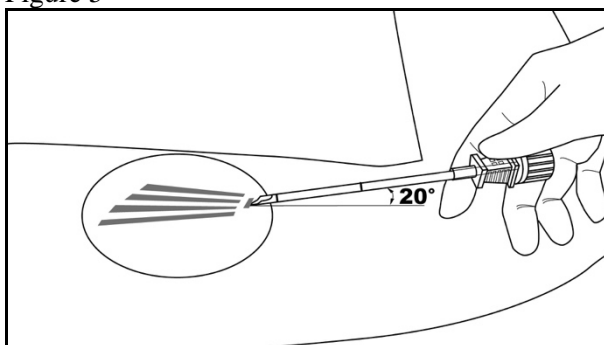

**Step 5:** Lower the applicator to a horizontal position; lift the skin up with the tip of the applicator, but keep the cannula in the subcutaneous connective tissue (Figure 6).



Figure 6

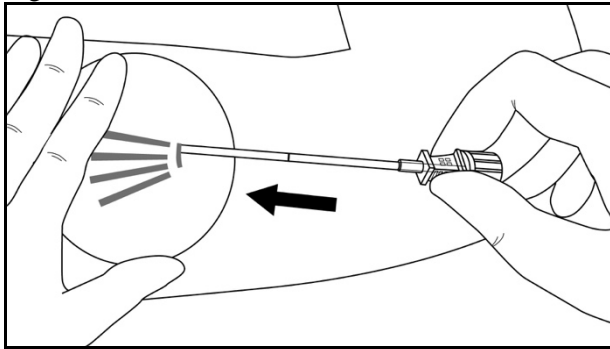

Step 6: While lifting, gently advance the applicator subcutaneously along the channel marking on the skin. Stop immediately once the proximal marking on the cannula has disappeared into the incision (Figures 7 and 8).

Figure 7

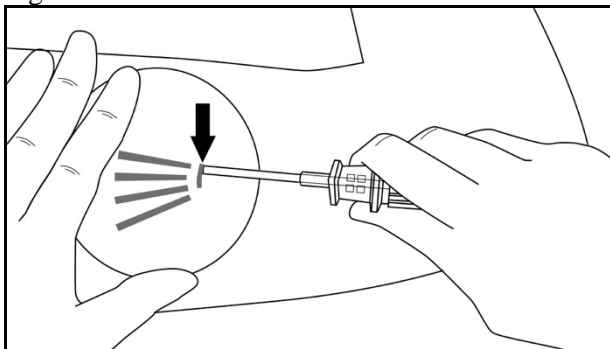
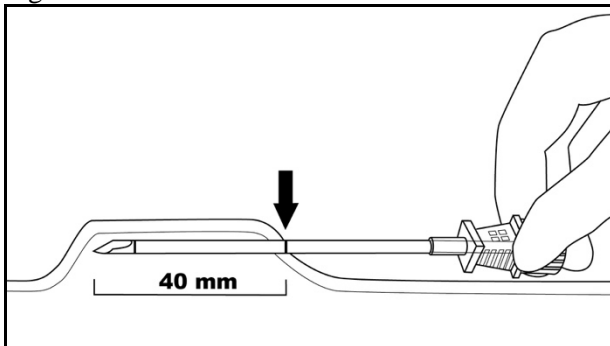

Figure 8



**Step 7:** While holding the cannula in place, unlock the obturator and remove the obturator. Insert one implant into the cannula (Figure 9), re-insert the obturator, and gently push the obturator forward (mild resistance should be felt) until the obturator stop line is level with the bevel-up stop marking, which indicates the implant is positioned at the tip of the cannula (Figure 10). **Do not force the implant beyond the end of the cannula with the obturator.** There should be at least 5 mm between the incision and the implant when the implant is properly positioned.

Figure 9

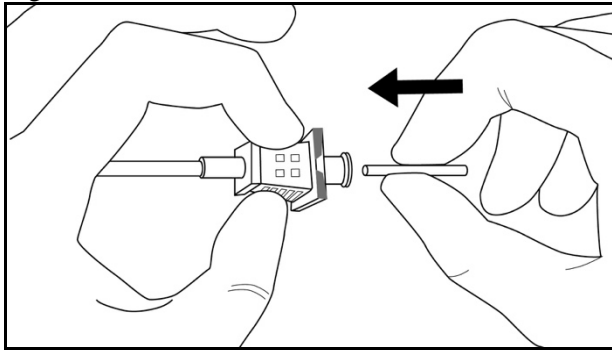
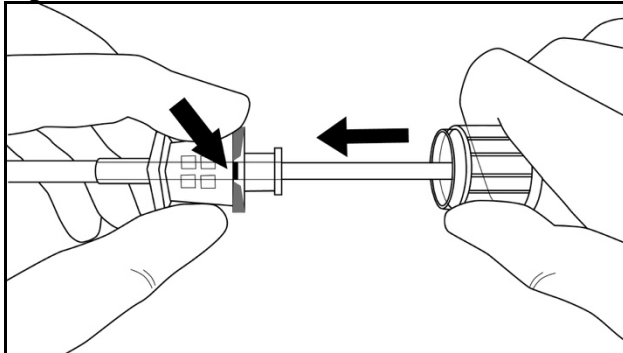

Figure 10



**Step 8:** While holding the obturator in place on the arm, retract the cannula along the obturator, leaving the implant in place (Figure 11). **Note: Do not push the obturator.** Withdraw the cannula until the hub is flush with the obturator, then twist the obturator clockwise to lock onto the cannula (Figure 12). Retract the applicator, bevel-up, until the distal marking of the cannula is visible at the incision opening (the sharp tip remaining in the subcutaneous space).

Figure 11

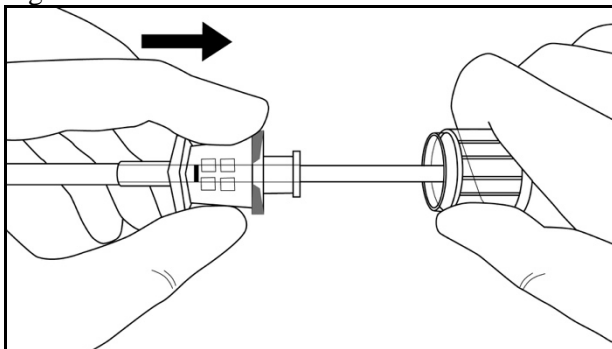
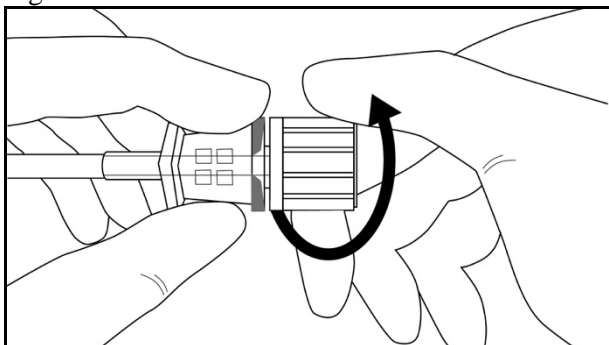
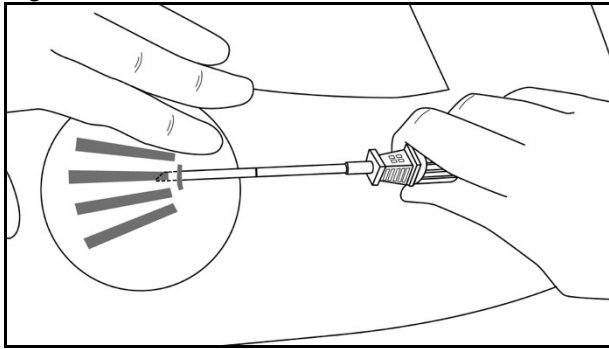

Figure 12



**Step 9:** Redirect the applicator to the next channel marking, while stabilizing the previously inserted implant with your index finger, away from the sharp tip (Figure 13). Follow steps 6 through 9 for the insertion of the three remaining implants through the same incision.

Figure 13



**Step 10:** Verify the presence of each implant (26.5 mm in length) by palpation of the patient's arm immediately after the insertion, as shown in Figure 14. If you cannot feel each of the four implants, or doubt their presence, use other methods to confirm the presence of the implant.

Figure 14

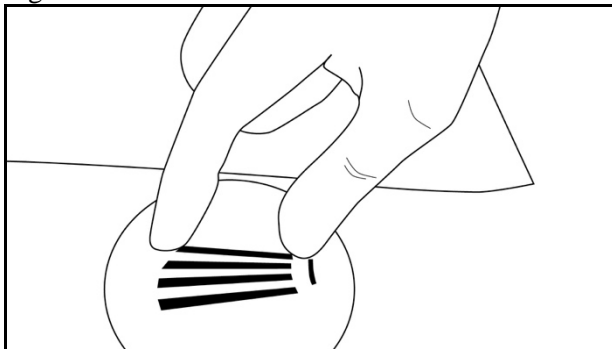

**Step 11:** Apply pressure to the incision site for approximately five minutes if necessary. Clean the incision site. Apply liquid adhesive to the skin margins and allow to dry before closing the incision with the thin adhesive strip around 6 mm wide (butterfly strip).

Place a small adhesive bandage over the insertion site. Apply a pressure bandage with sterile gauze to minimize bruising. Instruct the patient that the pressure bandage can be removed after 24 hours and the adhesive bandage removed in three to five days, and to apply an ice pack on the arm for 40 minutes every two hours for the first 24 hours, then as needed.

**Step 12:** Complete the Patient Alert Card and give it to the patient to keep. Also, scan or input the details of the implant procedure into the patient's medical records. Advise the patient on proper care of the insertion site.

#### **Instruction for location of implants prior to removal**

Verify the location of the implants by palpation. **Non-palpable implants must be located prior to attempted removal.** In the case of non-palpable implants, removal should be performed under ultrasound guidance (following their localisation). Suitable methods for location include ultrasound with a high frequency linear array transducer (10 MHz or greater) or, in case ultrasound is not successful, magnetic resonance imaging (MRI). Sixmo implants are not radiopaque and cannot be seen by X-ray or CT scan. Exploratory surgery without knowledge of the exact location of all implants is strongly discouraged.

## Equipment for removal of Sixmo

Implants should be removed under aseptic conditions, whereby the following equipment is needed:

- an examination table for the patient to lie on
- instrument stand covered with sterile drape
- adequate lighting, such as headlamp
- sterile fenestrated drapes
- latex, talc-free, sterile gloves
- alcohol pad
- surgical marker
- antiseptic solution, such as chlorhexidine
- local anaesthetic, such as 1% lidocaine with adrenaline 1:100,000
- 5 mL syringe with 25G×1.5" needle (0.5×38 mm)
- Adson single tooth tissue forceps
- mosquito forceps
- two X-plant clamps (vasectomy fixation clamps with 2.5 mm ring diameter)
- iris scissors
- needle driver
- #15 blade scalpel
- sterile ruler
- 100×100 mm sterile gauze
- adhesive bandage
- pressure bandage around 8 cm wide
- sutures, such as 4-0 Prolene™ with an FS-2 cutting needle (may be absorbable)

## Instructions for removal of Sixmo

**Step 13:** The patient should lie on their back, with the implant arm flexed at the elbow and externally rotated, so that the hand is positioned next to the head. Reconfirm the location of the implants by palpation. Clean removal site with alcohol pad prior to marking the skin. Using the surgical marker, mark the location of the implants and the location of the incision. The incision should be made parallel to the axis of the arm, between the second and third implants, to access the subcutaneous space (Figure 15).

Figure 15

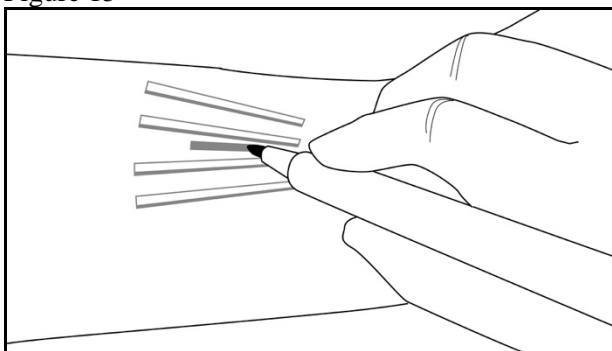

**Step 14:** Put on sterile gloves. Using aseptic technique, place the sterile equipment on the sterile field of the instrument stand. Clean the removal site with an antiseptic solution, such as chlorhexidine. Do not blot or wipe away. Apply the sterile drape to the patient's arm. Anaesthetise the incision site and the subcutaneous space containing the implants (for example, by injecting 5 to 7 mL lidocaine 1% with adrenaline 1:100,000).

NOTE: Be sure to inject the local anaesthetic deep to the centre of the implants; this will effectively lift the implants toward the skin, facilitating removal of the implants. After determining the anaesthesia is adequate and effective, make a 7 to 10 mm incision with a scalpel, parallel to the axis of the arm, between the second and third implants.

**Step 15:** Pick up the skin edge with Adson single toothed tissue forceps and separate the tissues above and below the visible implant, using an iris scissors or a curved mosquito forceps (Figure 16). Grasp the centre of the implant with the X-plant clamp(s) (Figure 17) and apply gentle traction. If the implant is encapsulated, or you see dimpling, use the scalpel to shave the adhering tissue to release the implant.

Figure 16

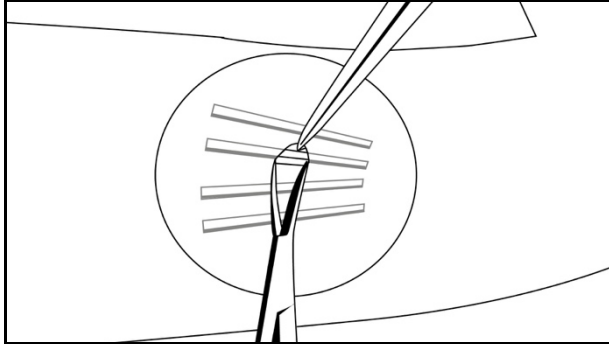
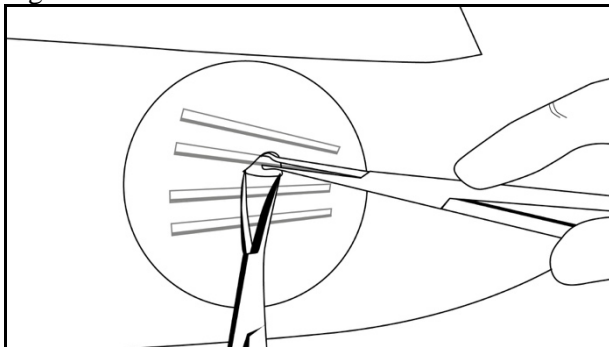

Figure 17



**Step 16:** After removal of each implant, confirm that the entire 26.5 mm long implant has been removed by measuring its length. Follow steps 15 and 16 for the removal of the remaining implants through the same incision. The same technique is employed for the removal of protruding or partially expelled implants. Exploratory surgery without knowledge of the exact location of all implants is strongly discouraged.

**Step 17:** After removal of all implants, clean the incision site. Close the incision with sutures. Place an adhesive bandage over the incision. Use the sterile gauze and apply gentle pressure to the incision site, for five minutes, to ensure haemostasis. Apply a pressure bandage with sterile gauze to minimize bruising. Instruct the patient that the pressure bandage can be removed after 24 hours and the adhesive bandage in three to five days. Counsel the patient on proper aseptic wound care. Instruct the patient to apply an ice pack to the arm for 40 minutes every two hours for first 24 hours, then as needed. Schedule an appointment for the sutures to be removed.

**Step 18:** Disposal of Sixmo implants should be in accordance with local requirements as it contains buprenorphine.

If implant(s) or implant fragment(s) are not removed during a removal attempt, the patient should undergo imaging for localisation as soon as is feasible with the subsequent removal attempt performed on the same day as localisation. If localisation and a second removal attempt are not performed on the same day as the initial removal attempt, the wound should be closed with sutures in the interim.