



EUROPEAN MEDICINES AGENCY
SCIENCE MEDICINES HEALTH

1 July 2011
EMA/399691/2011
Patient Health Protection
Superseded by v.2.0

Detailed guidance on the electronic submission of information on medicinal products for human use by marketing authorisation holders to the European Medicines Agency in accordance with Article 57(2), second subparagraph of Regulation (EC) No. 726/2004

Version 1.0

Date of coming into force: 1 July 2011

Key words:	electronic submission, medicinal product information, new pharmacovigilance legislation, format, substance, medicinal product
------------	---



Table of contents

Table of contents	2
1. Introduction	4
1.1. The format for the electronic submission of information on medicinal products by marketing authorisation holders	4
1.2. Electronic submission of information on medicinal products by marketing authorisation holders	4
1.3. Processing and validation of the information on medicinal products submitted to the Agency	5
2. Electronic submission of information on medicinal products by marketing authorisation holders	5
2.1. The Eudravigilance Product Report Message (EVPRM) submission methods	5
2.2. The EudraVigilance Product Report Message Acknowledgement (EVPRM_ACKs)	6
3. Eudravigilance Product Report Message (EVPRM)	6
3.1. Reference key management and resolution mode	6
3.2. EVPRM structure	7
3.2.1. The EVPRM structure overview	8
3.2.2. Message header	11
3.2.3. Organisation section	12
3.2.4. Source section	13
3.2.5. Development substances section	14
3.2.6. Approved substances section	15
3.2.7. Standard terminology section	16
3.2.8. Development product section	17
3.2.9. Authorised product section	18
3.2.10. Attachment section	23
3.2.11. Qualified Person Responsible for Pharmacovigilance (QPPV) section	24
3.2.12. Pharmacovigilance System Master File Location section	25
3.3. EVPRM data elements description	25
4. Structured Substance Information	55
4.1. The Structured Substance Information overview	56
4.1.1. The Structured Substance Information chemicals	57
4.1.2. The Structured Substance Information nucleic acid	58
4.1.3. The Structured Substance Information polymers	59
4.1.4. The Structured Substance Information proteins	60
4.1.5. The Structured Substance Information structurally diverse substances	61
4.1.6. The Structured Substance Information mixtures	62
4.1.7. The Structured Substance Information specified substance group 1	62
4.1.8. The Structured Substance Information specified substance group 2	63
4.1.9. The Structured Substance Information specified substance group 3	64
4.2. The Structured Substance Information data element description	64

4.2.1. Structred Substance Information (SSI) for chemical substances.....	64
4.2.2. SSI for nucleic acids.....	76
4.2.3. SSI for polymers.....	92
4.2.4. SSI for proteins.....	111
4.2.5. SSI for structurally diverse substances.....	128
4.2.6. SSI for mixture substances.....	146
4.2.7. SSI for specified substance – group 1.....	161
4.2.8. SSI for specified substance – group 2.....	173
4.2.9. SSI for specified substance – group 3.....	183
5. EV Product Report Message Acknowledgement Message.....	193
5.1. Acknowledgement Message (EVPRM_ACK).....	193
5.2. Acknowledgement structure.....	193
5.2.1. General structure.....	194
5.2.2. Acknowledgement message header.....	195
5.2.3. Acknowledgment sections.....	195
5.3. EVPRM Acknowledgement elements description.....	196
6. Annex: Definitions.....	201

1. Introduction

This Detailed Guidance has been prepared by the European Medicines Agency to comply with the requirements to publish a format for the electronic submission of information on medicinal products for human use authorised or registered in the Union as provided for in Article 57(2), second sub-paragraph of Regulation (EC) No 726/2004 and as referred in to the '*Legal Notice on the Implementation of Article 57(2), second subparagraph of Regulation (EC) No. 726/2004 - Electronic Submission of Information on Medicinal Products for Human Use by Marketing Authorisation Holders to the European Medicines Agency*'.

1.1. The format for the electronic submission of information on medicinal products by marketing authorisation holders

In accordance with Article 57(2), second sub-paragraph of Regulation (EC) No 726/2004, the format for the electronic submission of information on medicinal products for human use is published in this Detailed Guidance. This format is referred to as the EudraVigilance Product Report Message (EVPRM).

This Detailed Guidance, version 1.0 provides a listing and description of all data elements required for the electronic submission of information on all medicinal products for human use authorised or registered in the Union including the description of the characteristics of the substances contained in medicinal products.

Version 2.0 of this Detailed Guidance will include the XML Schema Definition Language (XSD).

1.2. Electronic submission of information on medicinal products by marketing authorisation holders

The electronic submission of medicinal product information can be achieved in two ways:

- Pharmaceutical companies can develop tools to initiate the electronic submissions of information on medicinal products in full compliance with the data elements and the XSD schema as referred to in chapter 1.1. via the EudraVigilance Gateway to the Agency.
- Pharmaceutical companies can use the data entry and submission tools provided by the Agency; the latter are specifically developed for Small and Medium Sized Enterprises (SMEs) but are made available to any pharmaceutical company for the purpose of electronic submission of information on medicinal products to the Agency.

A specific training programme for pharmaceutical companies is currently being developed by the Agency. Dates and the location for the training will be announced on the EMA and EudraVigilance website.

1.3. Processing and validation of the information on medicinal products submitted to the Agency

The Agency – with the support of a contractor – will process and validate the electronically submitted information on medicinal products to ensure that it is accurate and up to date. Where information is incomplete, missing or erroneous, the Agency will liaise with the marketing authorisation holder to complete or correct the information.

2. Electronic submission of information on medicinal products by marketing authorisation holders

Marketing authorisation holders shall electronically submit to the Agency information on all medicinal products for human use authorised or registered in the Union and shall maintain this information using the EudraVigilance Medicinal Product Report Message (EVPRM).

2.1. The Eudravigilance Product Report Message (EVPRM) submission methods

An EVPRM can be submitted to the European Medicines Agency in three ways:

- Using a pharmaceutical company's Gateway to exchange with the EudraVigilance (ESTRI) Gateway
- Using the EVWEB Trader
- Using the EudraVigilance WEB Application (EVWEB)

For all three submission methods, an XML file referred to as the **EudraVigilance Product Report Message (EVPRM)** (Figure 1) has to be generated.

EVWEB offers the possibility to create and send an EVPRM by entering information on medicinal products by means of a user-friendly interface. EVWEB can also be used for maintaining the information based on different operation types.

Further details about the EVPRM are referred to in chapters 3.2.

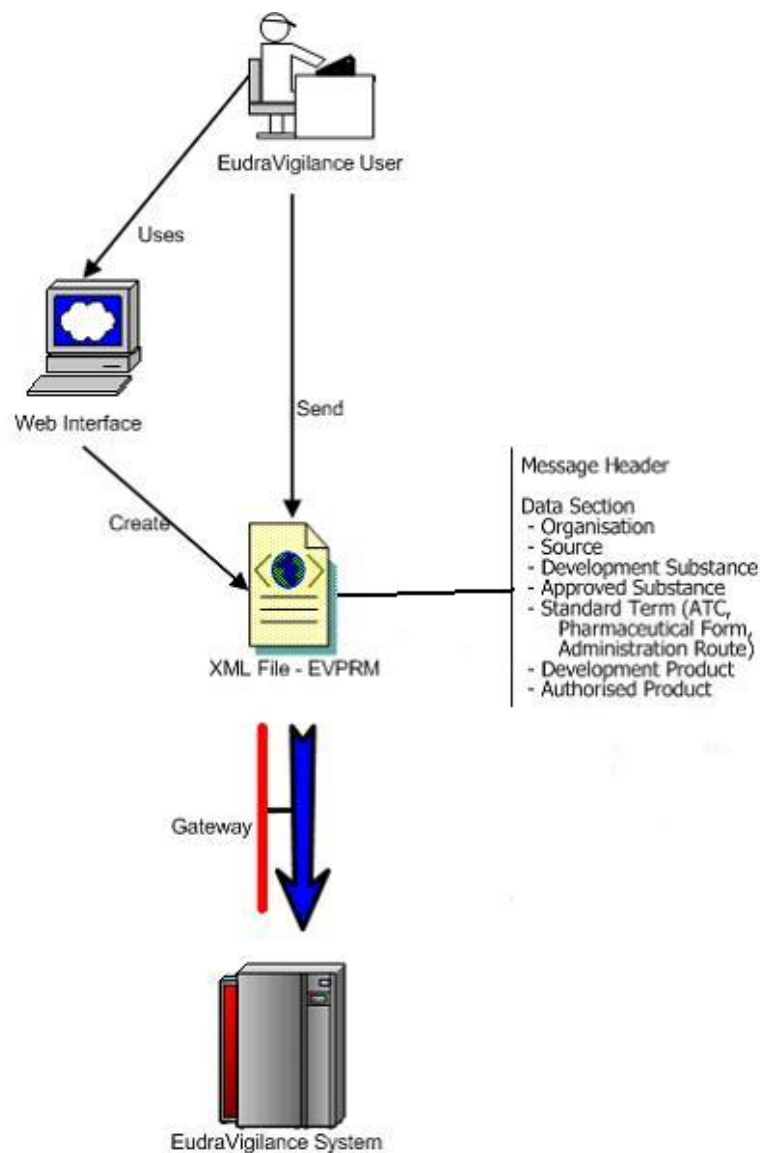

Figure 1 - Overview of the electronic submission of medicinal product information

2.2. The EudraVigilance Product Report Message Acknowledgement (EVPRM_ACKs)

For each EVPRM submitted to the EudraVigilance Gateway, an acknowledgement referred to as **EVPRM Acknowledgement (EVPRM_ACK)** is returned to the Sender Organisation. Further details are provided in chapter 5.

3. Eudravigilance Product Report Message (EVPRM)

3.1. Reference key management and resolution mode

For a set of entities (e.g. organisation, pharmaceutical dose form) with exception of the ATC Classification System code, the receiving system of the Agency automatically

generates a unique key referred to as EV Code (EudraVigilance Code). The EV Code is a global key that identifies an entity within the database and in the EVPRM. The Sender Organisation can uniquely refer to an entity generated using the EV Code.

The ATC Code is the EV Code for an ATC Term.

The following keys are the global keys generated for each entity:

1. EV Code Organisation
2. EV Code Source
3. ATC Code
4. EV Code Pharmaceutical Dose Form
5. EV Code Administration Route
6. EV Code Substance
7. EV Code Product

These global keys are used to join different entities within the database. For example, when a Sender Organisation has to specify a substance as an ingredient of a medicinal product, it uses the "EV Code Substance" to refer to the correct entity.

The EV Code is also used to support the operation types, which are used to maintaining the information on medicinal products submitted via the EVPRM.

If a Sender Organisation has to maintain an entry using the operation type 'Update', 'Variation', 'Nullify', 'Change Ownership' or 'Withdrawn', it also has to specify the EV Code of the entity related to the operation type.

The EVPRM contains a field in each section as applicable where the Sender Organisation can specify the appropriate EV Code.

When a Sender Organisation has to make reference to a specific entity, the following two scenarios are possible:

1. Referring to an entity, for which an EV Code is already available (**Global Key**).
2. Referring to a new entity reported in the EVPRM where no EV Code is yet available. The EVPRM contains a section (with operation type 'Insert') that permits for the new entity and its Local Number (**Local Key**) instead of the EV Code.

As a result, a Sender Organisation referring to an entity must specify whether the code used is a Global Key (EV_CODE) or a Local Key (Local Number). To do so each field that specifies a reference in the EVPRM XML schema has an attribute called Resolution Mode.

Resolution Mode = 1 → 'LOCAL' (The code specified is a Local Number).

Resolution Mode = 2 → 'GLOBAL' (The code specified is an EV_CODE).

3.2. EVPRM structure

The figures and data elements presented in this chapter are for illustration purposes.

Details on the mandatory sections and elements as well as the business rules applicable for each element will be addressed as part of the EVPRM XML Schema Definition Language (XSD) and technical instructions.

In the figures presented in this chapter for illustration purposes, the *mandatory sections/data elements* are presented as boxes with *solid lines* (e.g. as the message header) and the *non-mandatory sections/data elements* as boxes with *dotted lines* (e.g. as the Organisations, Sources, and Substances, Standard Terminology Substances and Products sections).

If business rules apply to a set of elements conferring mandatory status only in certain instances, the elements are represented as boxes with *dotted lines* (e.g. Strength of Active ingredients).

3.2.1. The EVPRM structure overview

The EVPRM has 11 sections, as presented in Figure 2.

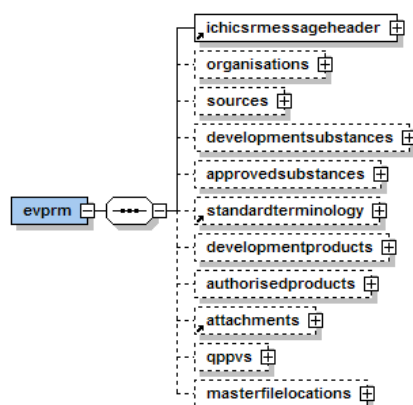

Figure 2 - EVPRM – Overall Structure

The Message Header is constructed in the same as the *ICHCSR message header for Individual Case Safety Reports*.

The *Sources* section contains information about reference *sources* with the possibility to specify operation type, which is explained below.

The *Organisation* section contains information about two types of *organisations*: Marketing Authorisation Holders and Sponsors. For each *organisation*, the applicable operation type needs to be also specified.

The *Development Substance* and *Approved Substance* sections contain information about the *substance(s)* contained in a product. More than one *substance* can be specified in one EVPRM. For each *substance* specified, the applicable operation types have to be selected.

The Standard Terminology section allows for the creation of new entries or maintaining existing entries in relation to *Organisations*, *Sources* or *Standard Terms* (*ATC Code*, *Pharmaceutical Form* and *Administration Route*).

- Three Standard Terminology sub-sections: *ATC Code*, *Pharmaceutical Form* and *Administration Route*. Each sub-section contains information about a specific *standard term*. The user can specify more than one *standard term* in the same EVPRM. For each *standard term* specified, the user can choose the applicable operation type.

The *Development Product* and *Authorised Product* sections contain all information about a medicinal *product*. Information on one or more medicinal products can be submitted electronically in the same EVPRM. For each *product* specified, the user can choose the applicable operation types.

The *Attachments section* contains the Product Information. The product information shall be produced by presenting in a single file the following regulatory documents as applicable:

- A copy of Annex I - Summary of product Characteristics
- A copy of Annex IIA - Manufacturing Authorisation Holder responsible for Batch Release
- A copy of Annex IIB - Conditions of the Marketing Authorisation
- A copy of Annex IIIA – Labelling
- A copy of Annex IIIB - Package Leaflet

The *Qualified Person Responsible for Pharmacovigilance (QPPV)* section refers to the name and address of the marketing authorisation holder's qualified person responsible for pharmacovigilance.

The *Master File Location* section refers to the location of the Pharmacovigilance System Master File of a marketing authorisation holder. The pharmacovigilance system master file is a detailed description of the pharmacovigilance system used by the marketing authorisation holder with respect to one or more authorised medicinal products.

The medicinal product information provided via the EVPRM is “owned” by the Sender Organisation that transmitted that information. The operation types that a Sender Organisation can perform by sending an EVPRM are as follows (table 1 Operation Types):

	Insert	Update	Variation	Nullify	Withdraw	Change Ownership
Authorised Product	✓	✓	✓	✓	✓	⊘
Development Product	✓	✓	⊘	✓	⊘	⊘
Approved Substance	✓	✓	⊘	✓	⊘	⊘
Development Substance	✓	✓	⊘	✓	⊘	⊘
Source	✓	✓	⊘	✓	⊘	⊘
MAH	✓	✓	⊘	✓	⊘	⊘
Sponsor	✓	✓	⊘	✓	⊘	⊘
Development Pharmaceutical Form	✓	✓	⊘	✓	⊘	⊘
Proposed Pharmaceutical Form	✓	✓	⊘	✓	⊘	⊘
Development Administration Route	✓	✓	⊘	✓	⊘	⊘
Proposed Administration Route	✓	✓	⊘	✓	⊘	⊘
Development ATC Code	✓	✓	⊘	✓	⊘	⊘
Proposed ATC Code	✓	✓	⊘	✓	⊘	⊘
Attachments	✓	⊘	⊘	⊘	⊘	⊘

Table 1- Operation Types

The possible operation types are:

- **Insert:** This operation type allows the Sender Organisation to provide new medicinal product information via an EVPRM.
- **Update:** This operation type allows the Sender Organisation to update the content of medicinal product information previously submitted via an EVPRM.
- **Variation:** This operation type allows the Sender Organisation to update medicinal product information of the marketing authorisation of an authorised medicinal product via an EVPRM. This update is related to *variations of a marketing authorisation*. This operation applies only to authorised medicinal products.

- **Nullify:** This operation type allows the Sender Organisation to nullify medicinal product information previously submitted via an EVPRM.
- **Withdraw:** This operation allows the Sender Organisation to inform about the withdrawal of an authorised medicinal product from the market via an EVPRM. This operation applies only to authorised medicinal products.
- **Change Ownership:** This operation type allows the current owner of the medicinal product information, which was submitted via an EVPRM, to notify the Agency that the information ownership is changing for any medicinal product (e.g. transfer of a marketing authorisation to another pharmaceutical company). The initial owner has to inform the Agency about these changes. This operation applies to authorised medicinal products, development products and development substances.

3.2.2. Message header

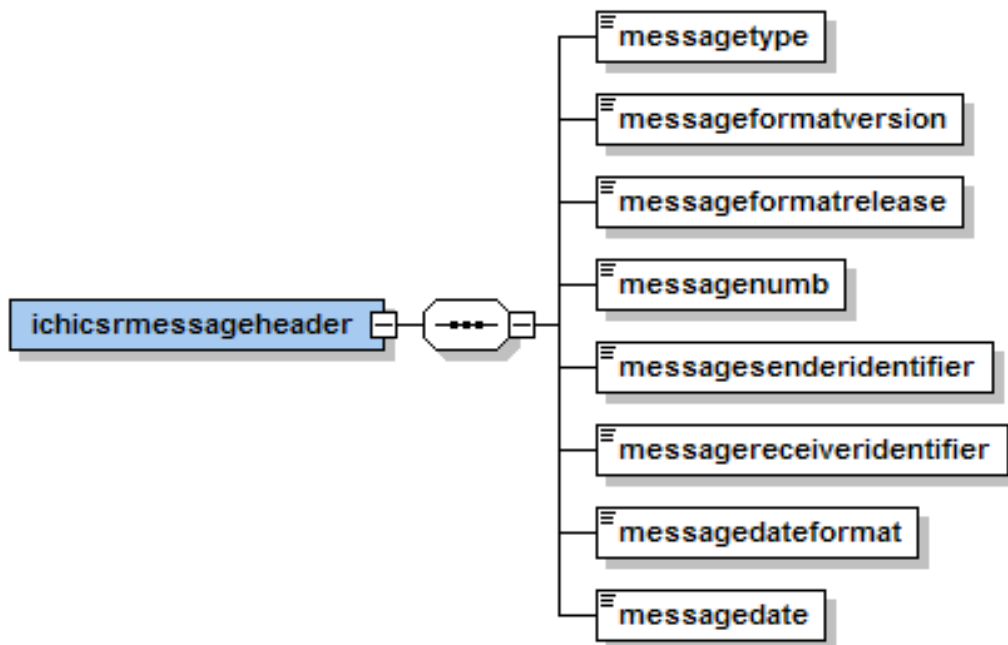

Figure 3 - EVPRM - Message Header Section

3.2.3. Organisation section

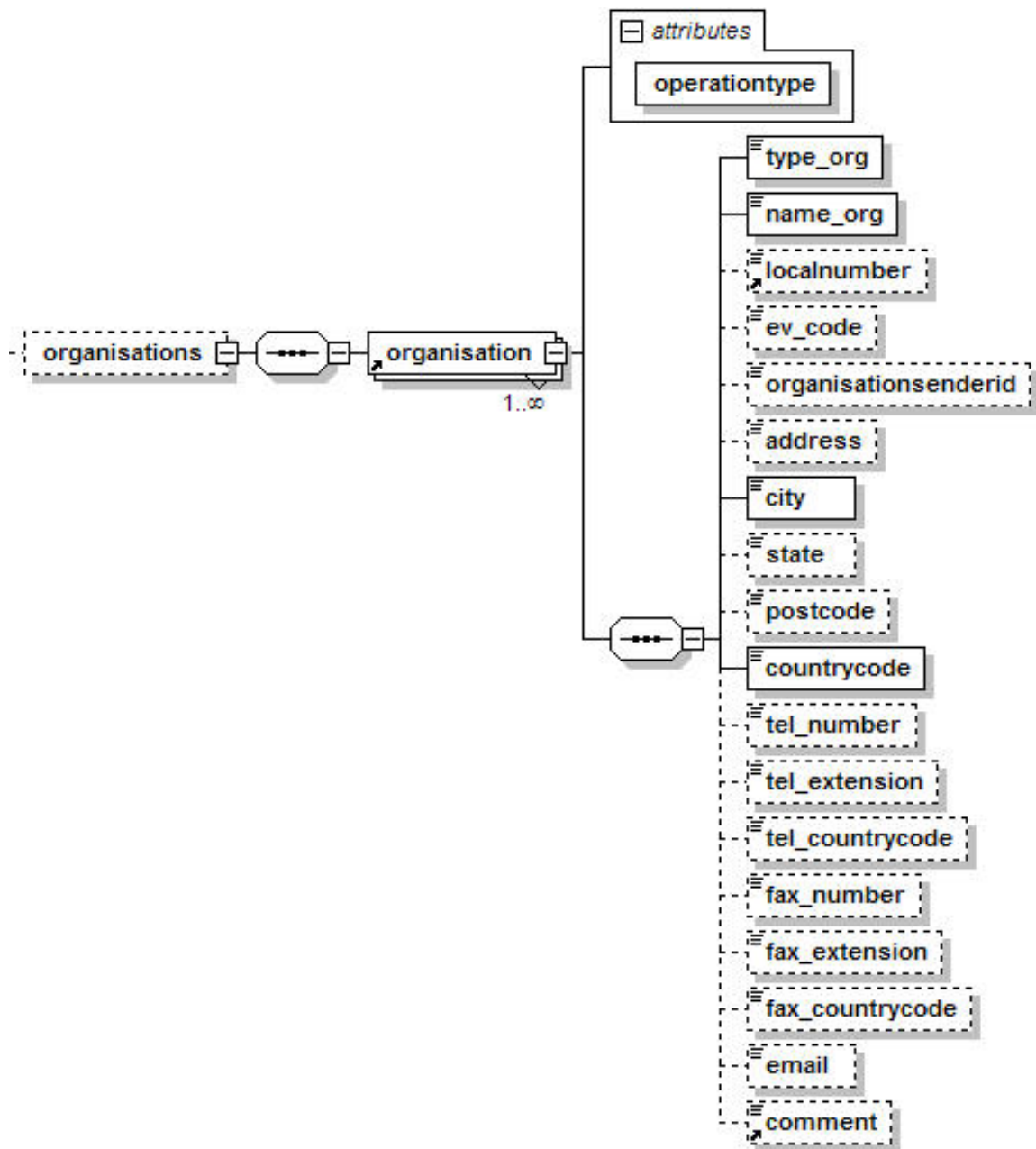

Figure 4 - EVPRM - Organisation Section

3.2.4. Source section

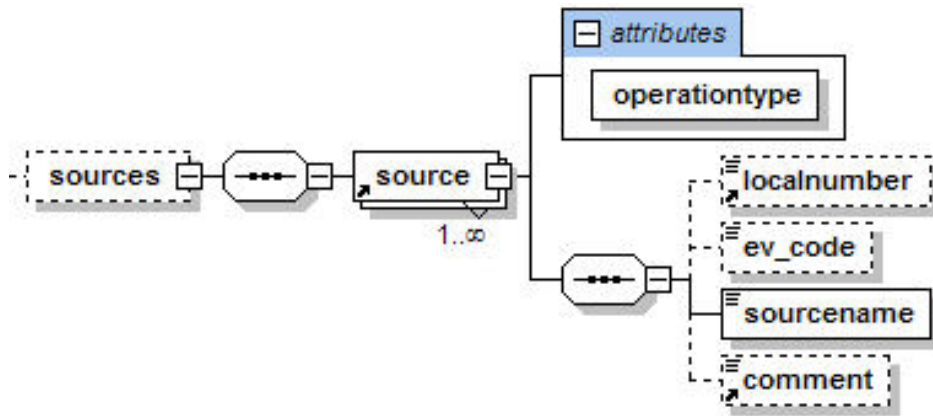

Figure 5 - EVPRM - Source Section

3.2.6. Approved substances section

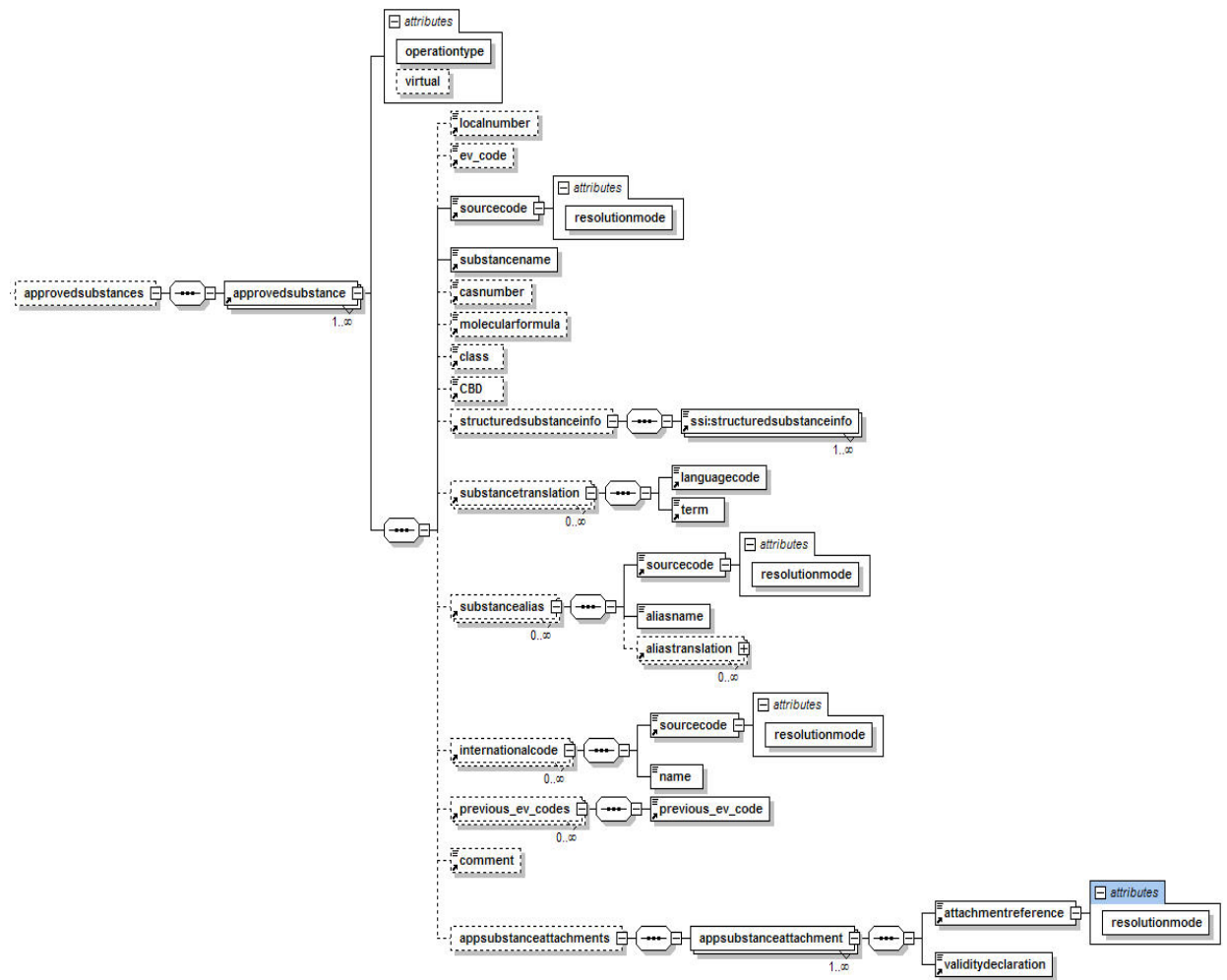

Figure 7 - EVPRM – Approved Substance Section

3.2.7. Standard terminology section

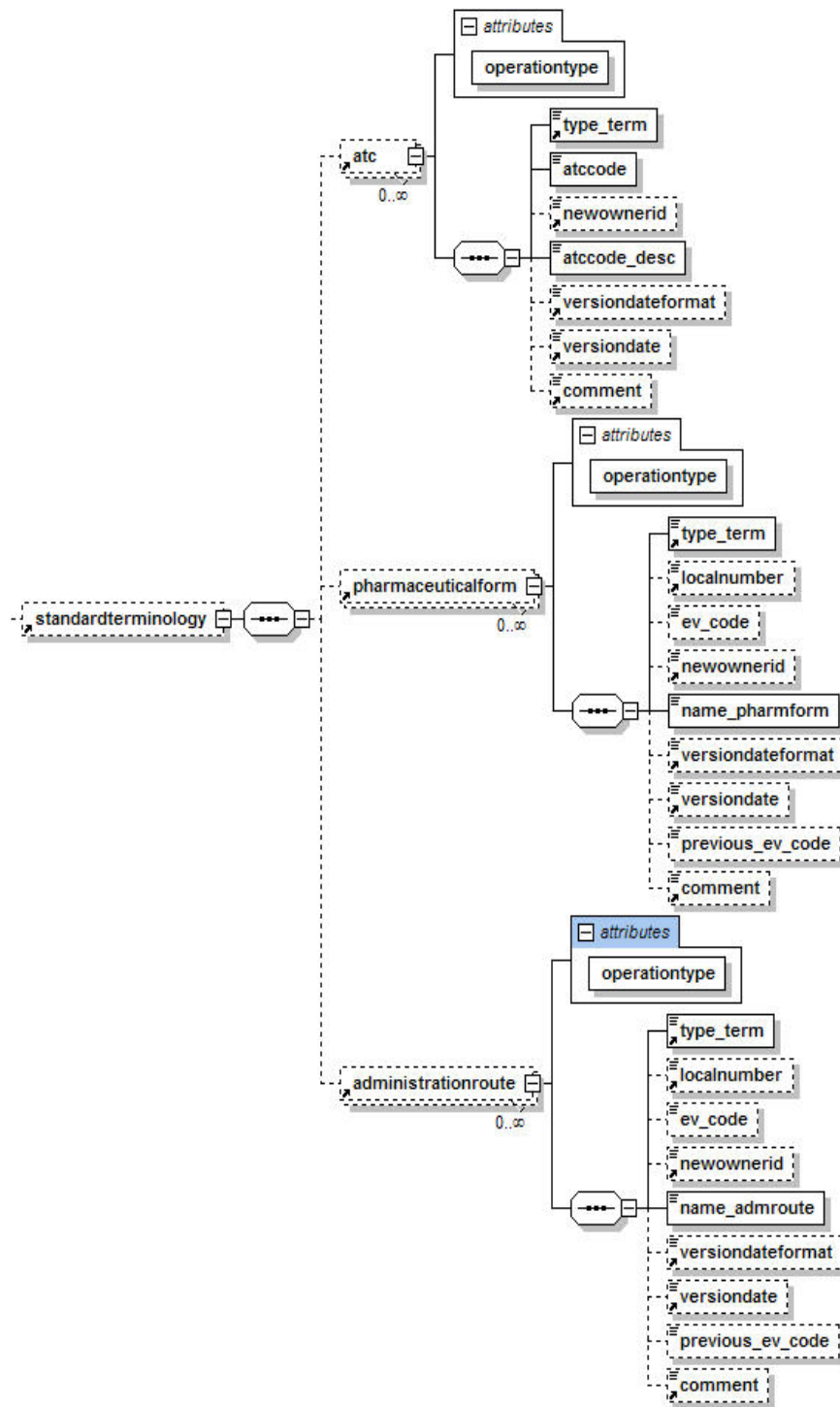

Figure 8 - EVPRM – Standard Terminology Section

3.2.8. Development product section

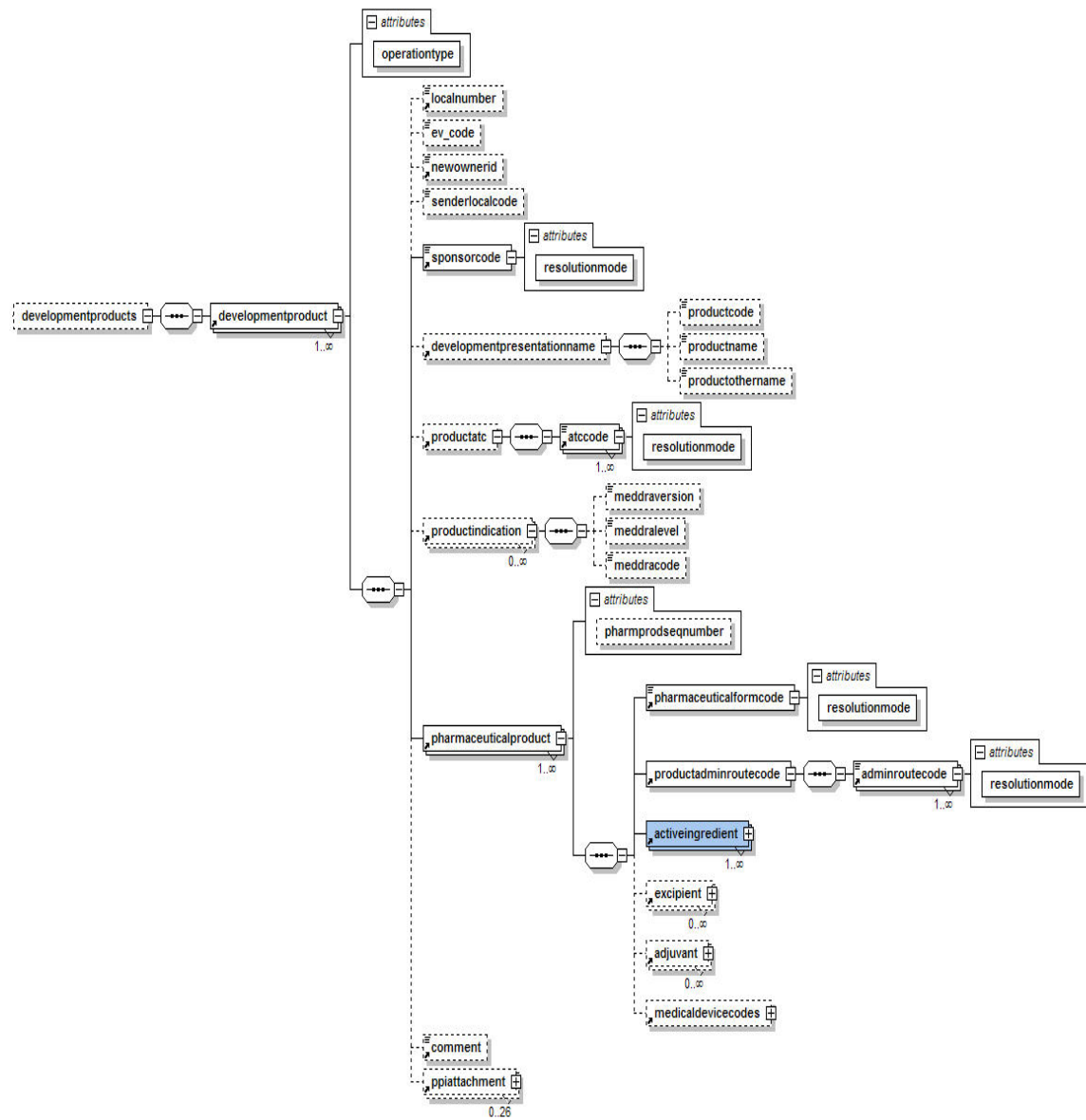

Figure 9 - EVPRM – Development Product Section

3.2.9. Authorised product section

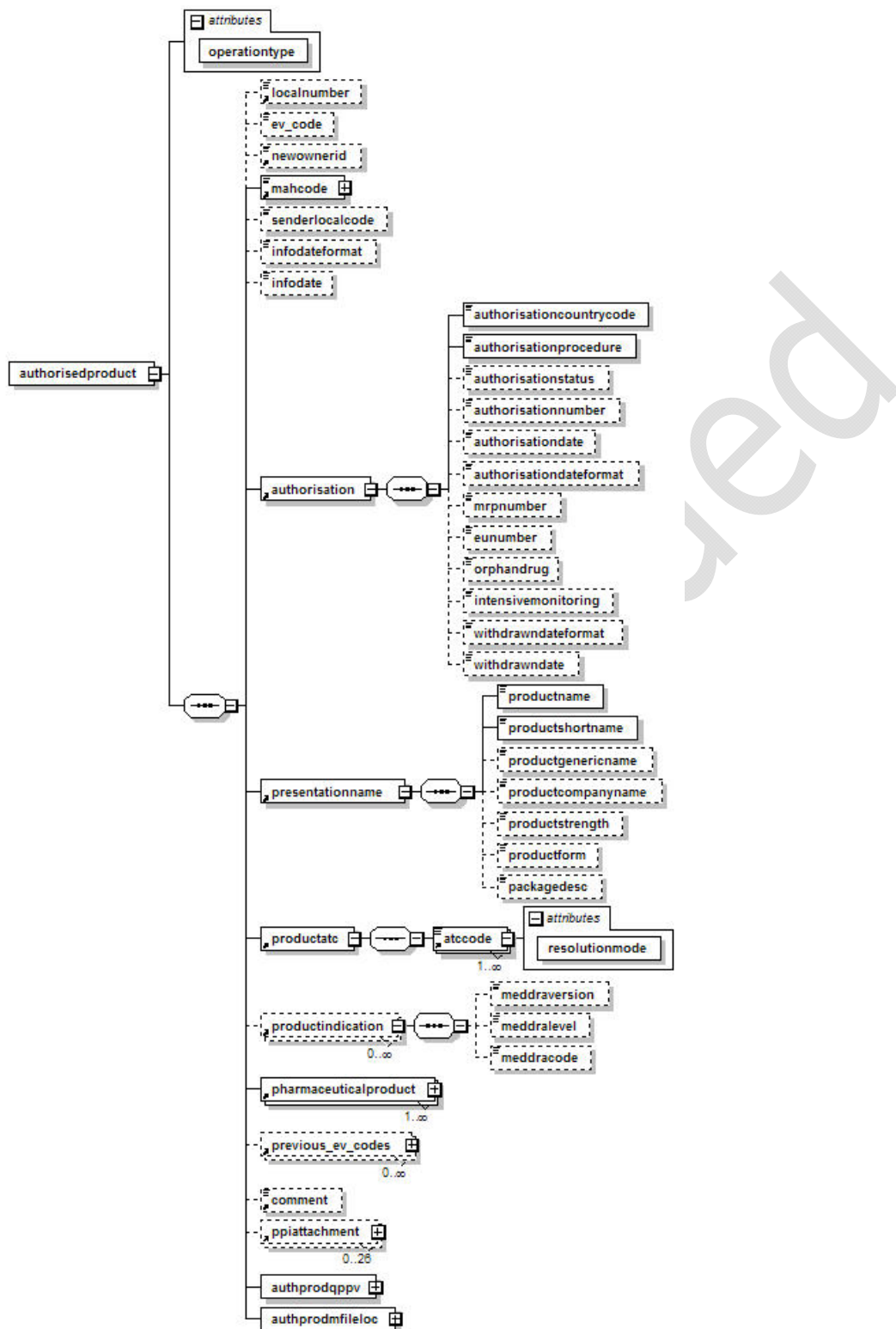

Figure 10 - EVPRM - Authorised Product Section – part 1

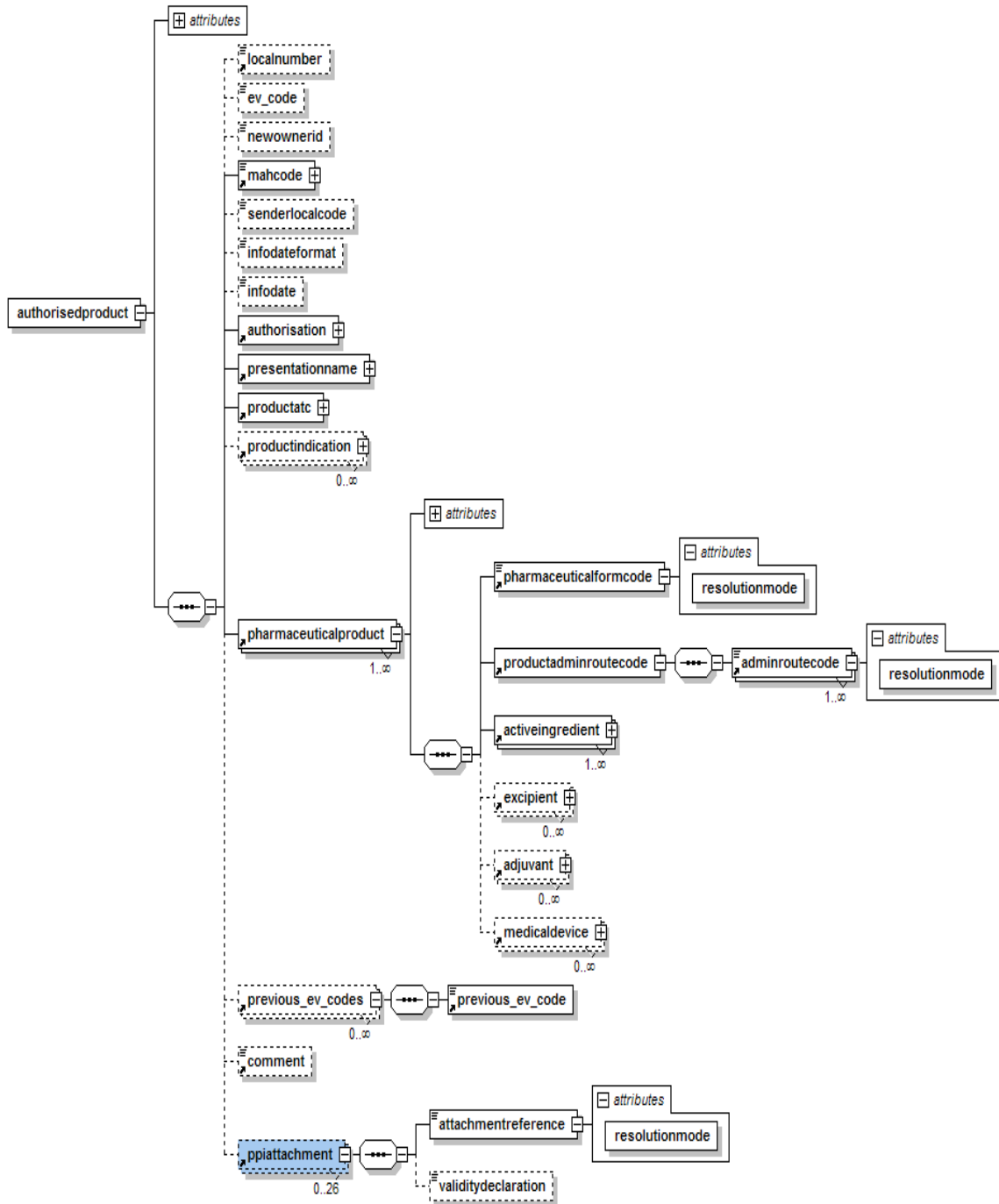

Figure 11 - EVPRM - Authorised Product Section – part 2

In the EVPRM Schema the ingredients of a medicinal product are structured in three sections as shown in the following figures:



Figure 12 - EVPRM - Authorised Product Section – Active Ingredient

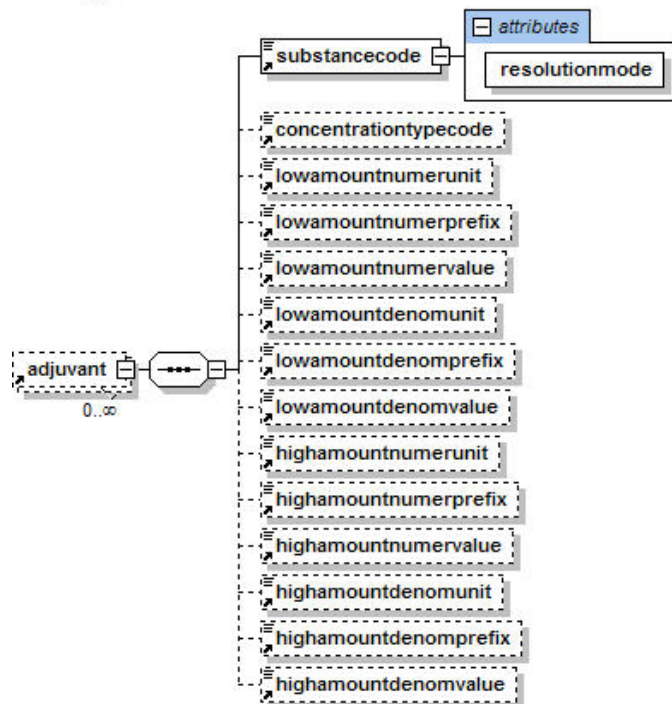

Figure 13 - EVPRM - Authorised Product Section – Adjuvant

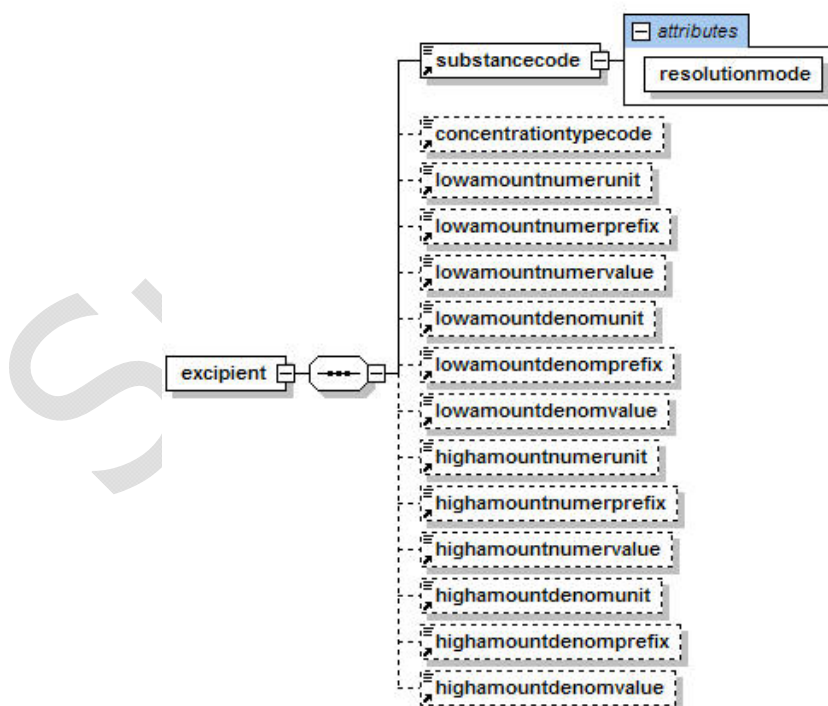

Figure 14 - EVPRM - Authorised Product Section – Excipient

In the EVPRM Schema the medical device¹ of a medicinal product is included in the pharmaceutical product section:

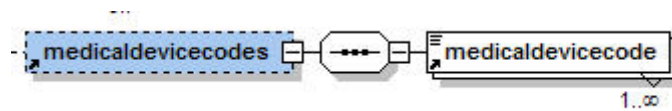

Figure 15 - EVPRM - Authorised Product Section – Medical Device

The difference between the active ingredient, excipient and adjuvant sections in the XML Schema is that the *concentrationtypecode*, *concentrationunitcode* and *concentration* are only mandatory for the active ingredient and adjuvant.

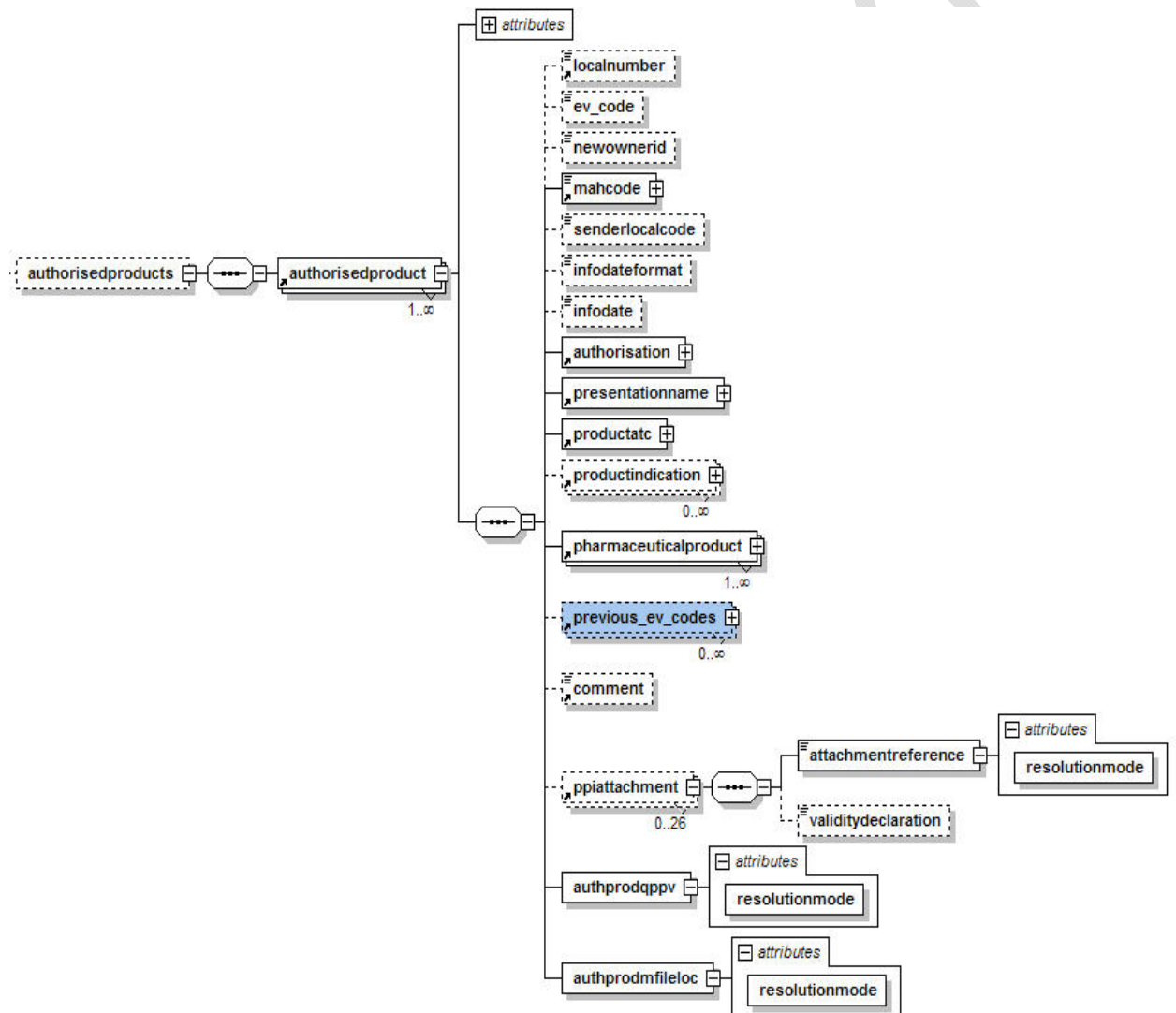

Figure 16 - EVPRM - Authorised Product Section – part 3

¹ This refers e.g. to combination products as set out in REGULATION (EC) No 1394/2007

3.2.10. Attachment section

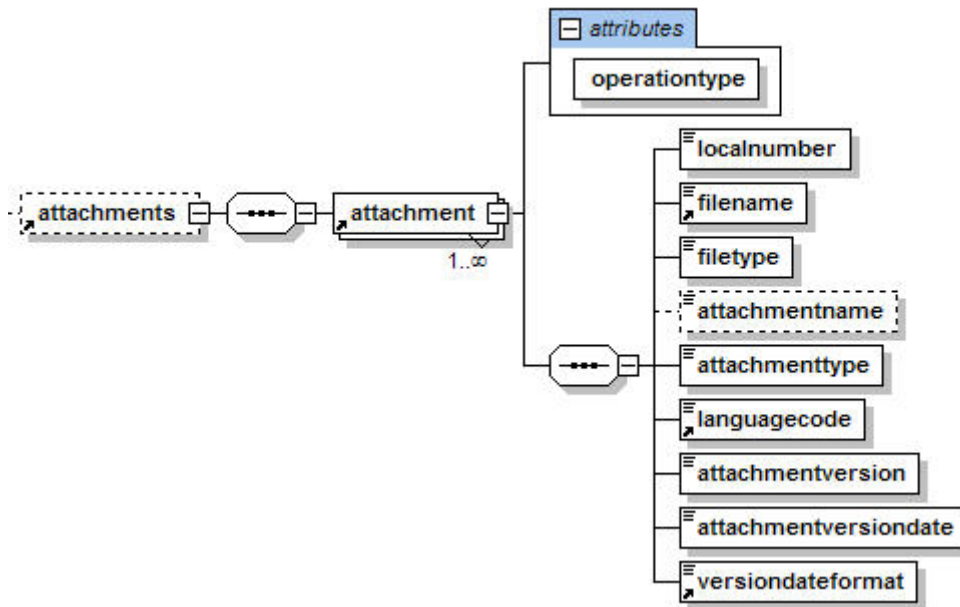

Figure 17 - EVPRM – Attachment Section

3.2.11. Qualified Person Responsible for Pharmacovigilance (QPPV) section

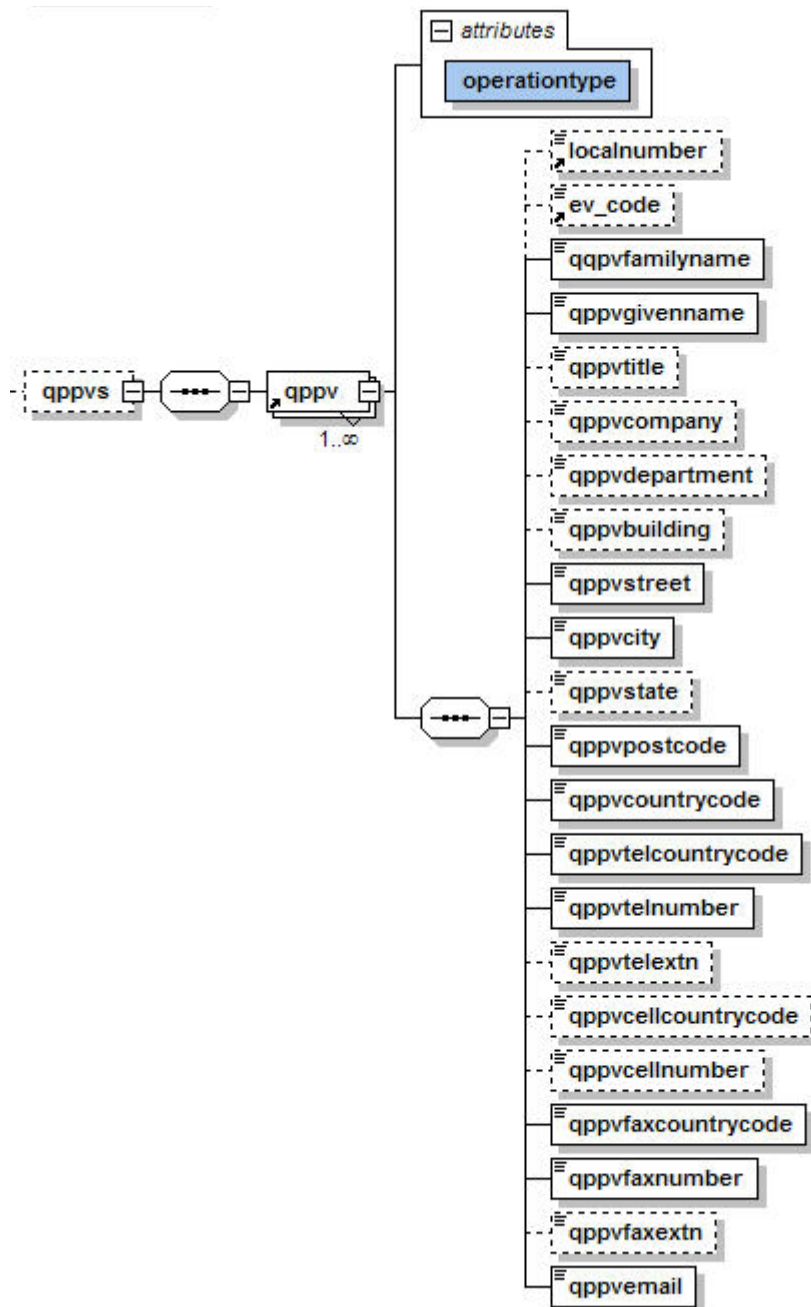

Figure 18 - EVPRM – QPPV Section

3.2.12. Pharmacovigilance System Master File Location section

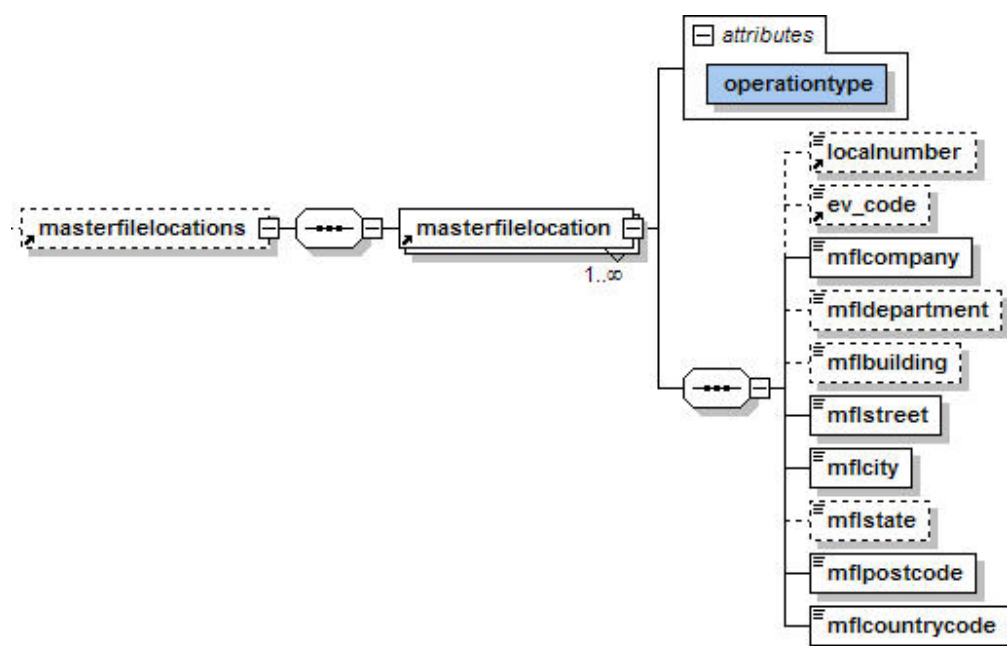

Figure 19 - EVPRM –Master File Location Section

3.3. EVPRM data elements description

The following table provides a list of the data elements related to the medicinal product information that shall be provided using the EVPRM XSD schema.

Data element name	Data element description
evprm See chapter 3.2.	The EudraVigilance Medicinal Product Report Message (EVPRM)
ichicsrmessageheader See chapter 3.2.2.	The message header section shall be specified. It shall contain information related to sender, receiver, the type of information being transmitted and the transmission date.
messagetype	The message type shall be specified. It shall contain information on the type of information being transmitted. When creating a message, the value of this field shall be "XEVRM".
messageformatversion	The message format version shall be specified. It shall contain the version number of the XSD SCHEMA.

Data element name	Data element description
messageformatrelease	The message format release shall be specified. It refers to the release number of the message format version of the XSD SCHEMA.
messagenumb	The message number shall be specified. It refers to the unique tracking number assigned to a specific medicinal product report message file transmitted by the sender. The message number is unique to the sender.
messagesenderidentifier	The message sender identifier shall be specified. It refers to the unique identifier of the sender organisation as assigned during the EudraVigilance registration process.
messagereceiveridentifier	The message receiver identifier shall be specified. This refers to the unique identifier of the receiving organisation i.e. the European Medicines Agency.
messagedateformat	The date format of the message shall be specified, which shall conform to the format "CCYYMMDDHHMMSS"
messagedate	The date of the message shall be specified, which shall conform to the format "CCYYMMDDHHMMSS"
organisation See chapter 3.2.3.	The organisation section This section shall be used to provide data on a new organisation and/or to updated information about an existing organisation (e.g. add telephone number or email address).
type_org	The type of organisation shall be specified i.e. marketing authorisation holder (MAH).
name_org	The name of the MAH shall be specified.
localnumber	The internal identification number of the MAH organisation shall be specified. The field is mandatory for the "Insert" operation.
ev_code	The EVcode of the organisation shall be specified. An EVcode is assigned to every new organisation. This field is mandatory if the operation type is NOT "Insert".
organisationsenderid	The ID of the organisation that sends the information shall be provided. This corresponds to the message sender organisation identifier as referred to in H5.

Data element name	Data element description
address	The address of the organisation shall be specified.
city	The city of the organisation shall be specified.
state	The state of the organisation shall be specified, where applicable.
postcode	The postcode of the organisation shall be specified.
countrycode	The country code of the location of the organisation shall be specified.
tel_number	The telephone number of the organisation shall be specified.
tel_extension	The extension telephone number of the organisation shall be specified, where applicable.
tel_countrycode	The telephone country code of the organisation shall be specified.
fax_number	The fax number of the organisation shall be specified, where applicable.
fax_extension	The fax number extension of the organisation shall be specified, where applicable.
fax_countrycode	The fax number country code of the organisation shall be specified, where applicable.
email	The email address of the organisation shall be specified, where applicable.
comment	<p>Further information on the organisation can be supplied in the comments field, if required.</p> <p>When the organization information shall be nullified, the comment field is mandatory and the reason for nullification shall be provided.</p>
sources See chapter 3.2.4.	<p>The source section</p> <p>Information on the bibliographical source of the information shall be provided where applicable.</p> <p>A new reference source and/or an update to an existing reference source can be specified.</p>
localnumber	<p>The internal identification number shall be specified for the source.</p> <p>The field is mandatory for the "Insert" operation.</p>
ev_code	<p>The EVcode of the reference source shall be specified.</p> <p>An EVcode is assigned to every new reference source.</p> <p>This field is mandatory if the operation type is NOT "Insert".</p>
sourcename	The name of the reference source shall be provided.

Data element name	Data element description
comment	<p>Further information may be supplied in the comment field.</p> <p>When the source information shall be nullified, the comment field is mandatory and the reason for nullification shall be provided.</p>
<p>developmentsubstances</p> <p>See chapter 3.2.5.</p>	<p>The development substances section</p> <p>This section is applicable to substances that are contained in medicinal product which are NOT yet authorised. For these substances specific confidentiality rules apply.</p> <p>This section shall be used to provide data on a new development substances /or to update information about a development substance for investigational medicinal products.</p>
localnumber	<p>The internal identification number shall be specified for the development substance.</p> <p>The field is mandatory for the "Insert" operation.</p>
ev_code	<p>The EVcode of the development substance shall be specified.</p> <p>An EVcode is assigned to every new development substance.</p> <p>This field is mandatory if the operation type is NOT "Insert".</p>
sponsorcode	<p>The code of the sponsor shall be specified.</p> <p>The sponsor code shall have an attribute 'Resolution Mode':</p> <ul style="list-style-type: none"> • Resolution mode 1 when the code is a Local Number; this is mandatory if the operation type is NOT "Insert". • Resolution mode 2 when the code is an ev_code; this is mandatory if the operation type is NOT "Insert".
casnumber	<p>The Chemical Abstracts Service (CAS) number of the development substance shall be specified, where applicable.</p>
molecularformula	<p>The empiric molecular formula of the development substance shall be specified, where applicable.</p>
class	<p>The development substance classification shall be specified.</p>
CBD	<p>The description of the development substance shall be provided in the Chemical and Biological Description (CBD).</p>

Data element name	Data element description
<i>developmentsubstancenames</i>	Development substance name section
developmentsubstancename	The development substance section shall be used to specify the name and/or code of the development substance.
substancename	The name and/or code of the development substance shall be specified in English.
preferred	It shall be specified if the development substance name is a preferred name. The value 1 is applicable if the name is a preferred name; The value 2 is applicable if the name is a preferred name.
iscode	It shall be specified if the development substance name specified is a code. The value is 1 if the name or the code specified is a code; The value is 2 if the name or the code specified is NOT a code.
internationalcode	Any internationally recognized code by which the development substance can be identified shall be specified as applicable.
sourcecode	A valid reference source of the approved substance name shall be specified. The Source code must have an attribute 'Resolution Mode': <ul style="list-style-type: none"> Resolution mode 1 when the code is a Local Number; this is mandatory if the operation type is NOT "Insert". Resolution mode 2 when the code is an ev_code; this is mandatory if the operation type is NOT "Insert".
name	The name of the reference source shall be provided.
structuredsubstanceinfo	The detailed description of the substance shall be provided in the form of an attached XML file in accordance with the data elements described in chapter 4.
<i>devsubstanceattachments</i>	Development Substance Attachment Section This section allows for the specification of the reference(s) to file attachments relevant to the development substance.
devsubstanceattachment	Development substance attachment section This section allows for the specification of the reference to a development substance attachment.

Data element name	Data element description
attachmentreference	<p>The details of the attachment for the development substance shall be specified.</p> <ul style="list-style-type: none"> Resolution mode 1 when the code is a Local Number; this is mandatory if the operation type is NOT "Insert". Resolution mode 2 when the code is an ev_code; this is mandatory if the operation type is NOT "Insert".
validitydeclaration	<p>In performing an update of existing medicinal product information where an attachment for a development substance was already previously loaded and referenced, a confirmation shall be provided that the referenced attachment is the latest version of the documentation.</p> <p>The value is 1 if the attachment is the latest version.</p>
comment	<p>Further information on the development substance may be supplied in the comment field.</p> <p>When the development substance shall be nullified, the comment field is mandatory and the reasons for nullification shall be provided.</p>
<p>approvedsubstances</p> <p>See chapter 3.2.6.</p>	<p>The approved substance section</p> <p>This section is applicable to substances that are contained in medicinal product which are authorised. For these substances specific confidentiality rules apply.</p> <p>This section shall be used to provide data on a new development substances /or to update information about a development substance for investigational medicinal products.</p>
approvedsubstance	<p>The approved substance section shall be used to specify the name of a substance, which is already in the public domain.</p>
localnumber	<p>The internal identification number shall be specified for the approved substance.</p> <p>The field is mandatory for the "Insert" operation.</p>
ev_code	<p>The EVcode of the approved substance shall be specified.</p> <p>An EVcode is assigned to every new approved substance.</p> <p>This field is mandatory if the operation type is NOT "Insert".</p>

Data element name	Data element description
sourcecode	<p>A valid reference source of the approved substance name shall be specified</p> <p>The Source code must have an attribute 'Resolution Mode':</p> <ul style="list-style-type: none"> Resolution mode 1 when the code is a Local Number; this is mandatory if the operation type is NOT "Insert". Resolution mode 2 when the code is an ev_code; this is mandatory if the operation type is NOT "Insert".
substancename	The name of the approved substance in English shall be provided.
casnumber	The Chemical Abstracts Service (CAS) number of the approved substance shall be specified, where applicable.
molecularformula	The empiric molecular formula of the approved substance shall be specified, where applicable.
class	The approved substance classification shall be specified.
CBD	The description of the approved substance shall be provided in the Chemical and Biological Description (CBD).
substancetranslation	<p>Substance translation section</p> <p>An official translation of the substance name shall be provided or updated using this section.</p>
languagecode	The code of the language for the substance name shall be specified using the EV language code list.
term	The translation of the substance name shall be specified, where applicable.
substancelias	<p>The substance alias section</p> <p>Where applicable, one or more synonyms of the substance name shall be provided or updated using this section.</p>

Data element name	Data element description
sourcecode	<p>A valid reference source of the approved substance name shall be specified</p> <p>The Source code must have an attribute 'Resolution Mode':</p> <ul style="list-style-type: none"> Resolution mode 1 when the code is a Local Number; this is mandatory if the operation type is NOT "Insert". Resolution mode 2 when the code is an ev_code; this is mandatory if the operation type is NOT "Insert".
aliasname	The synonym of the substance name shall be specified.
aliastranslation	<p>The alias name section</p> <p>Where applicable, one or more translations of the substance alias name shall be provided or updated using this section.</p>
languagecode	The code of the language for the substance name shall be specified using the EV language code list.
term	The translation of the substance alias name shall be specified.
internationalcode	Any internationally recognised code by which the substance alias name can be identified shall be specified as applicable.
sourcecode	<p>A valid reference source of the approved substance name shall be specified.</p> <p>The Source code must have an attribute 'Resolution Mode':</p> <ul style="list-style-type: none"> Resolution mode 1 when the code is a Local Number; this is mandatory if the operation type is NOT "Insert". Resolution mode 2 when the code is an ev_code; this is mandatory if the operation type is NOT "Insert".
name	The name of the reference source shall be provided.
<i>previous_ev_codes</i>	<p>The previous EV Code section</p> <p>This section shall be used when an approved substance shall be linked to the EVcode of a development substance.</p>
previous_ev_code	The EVCode of the development substance shall be specified, if applicable.

Data element name	Data element description
structuredsubstanceinformation	<p>Additional information related to the substance shall be provided in this section as an XML file attachment.</p> <p>The detailed characteristics identifying the substance shall be provided in a structured way as described in chapter 4.</p>
structuredsubstanceinfo	<p>The detailed description of the substance shall be provided in the form of an attached XML file in accordance with the data elements described in chapter 4.</p>
apps substance attachments	<p>Approved Substance Attachment Section</p> <p>This section allows for the specification of the reference(s) to file attachments relevant to the development substance.</p>
apps substance attachment	<p>Approved substance attachment section</p> <p>This section allows for the specification of the reference to a development substance attachment.</p>
attachmentreference	<p>The details of the attachment for the approved substance shall be specified.</p> <ul style="list-style-type: none"> • Resolution mode 1 when the code is a Local Number; this is mandatory if the operation type is NOT "Insert". • Resolution mode 2 when the code is an ev_code; this is mandatory if the operation type is NOT "Insert".
validitydeclaration	<p>In performing an update of existing medicinal product information where an attachment for an approved substance was already previously loaded and referenced, a confirmation shall be provided that the referenced attachment is the latest version of the documentation.</p> <p>The value is 1 if the attachment is the latest version.</p>
comment	<p>Further information may be supplied in the comment field.</p> <p>When the substance information shall be nullified, the comment field is mandatory and the reason of nullification shall be provided.</p>
standardterminology See chapter 3.2.7.	<p>The standard terminology section</p> <p>This section shall be used for the reference of standard terms: the Anatomical Therapeutic Chemical (ATC) classification system, Pharmaceutical Forms and Administration Routes.</p>

Data element name	Data element description
<i>atc</i>	<p>The ATC section</p> <p>This section shall be used to provide information about a new term in the ATC classification system and/or to update an existing term.</p>
type_term	<p>The type of the term shall be specified as follows:</p> <ul style="list-style-type: none"> • 1 - if the term is related to a development product and confidentiality rules applies; • 2 - if the term has been proposed as a new term to the maintenance organisation but no official term has yet been assigned; • 3 - if the term has been accepted by the maintenance organisation as an official term.
atccode	The ATC code value shall be specified.
atccode_desc	The ATC classification term in English shall be provided.
versiondateformat	<p>The format of the version date shall be specified:</p> <p>It shall conform to the format "CCYYMMDD".</p>
versiondate	<p>The version date of the list shall be specified:</p> <p>It shall conform to the format "CCYYMMDD".</p>
comment	<p>Further information may be provided in the comment field.</p> <p>When the term shall be nullified, the comment field is mandatory and the reason of nullification shall be provided.</p>
<i>pharmaceuticalform</i>	<p>The pharmaceutical dose form section</p> <p>The pharmaceutical dose form section shall be used to provide information about a new pharmaceutical dose form term and/or to update information about an existing pharmaceutical dose form term.</p>
type_term	<p>The type of the term shall be specified as follows:</p> <ul style="list-style-type: none"> • 1 - if the term is related to a development product and confidentiality rules applies; • 2 - if the term has been proposed as a new term to the maintenance organisation but no official term has yet been assigned; • 3 - if the term has been accepted by the maintenance organisation as an official term.
localnumber	<p>The internal identification number shall be specified for a pharmaceutical dose form.</p> <p>The field is mandatory for the "Insert" operation.</p>

Data element name	Data element description
ev_code	<p>The Eudravigilance Code (EV Code) of the pharmaceutical dose form shall be provided.</p> <p>The field is mandatory if the operation type is NOT an "Insert" operation.</p>
name_pharmform	<p>The name of the pharmaceutical dose form in English shall be provided.</p>
versiondateformat	<p>The format of the version date shall be specified.</p> <p>It shall conform to the format "CCYYMMDD".</p>
versiondate	<p>The version date shall be specified.</p> <p>It shall conform to the format "CCYYMMDD".</p>
previous_ev_code	<p>The EVCode of a "development" pharmaceutical dose form shall be specified, where applicable.</p> <ul style="list-style-type: none"> • For a "proposed term", the EVcode the development term shall be specified, where applicable. • For an official term, the EVcode of the "proposed term" shall be specified, where applicable. • For a "development term" this is not applicable.
comment	<p>Further information may be supplied in the comment field.</p> <p>When the term shall be nullified, the comment field is mandatory and the reasons for nullification shall be provided.</p>
administrationroute	<p>The route of administration section</p> <p>The route of administration section shall be used to provide information about a new route of administration term and/or to update information about an existing route of administration term.</p>
type_term	<p>The type of the term shall be specified as follows:</p> <ul style="list-style-type: none"> • 1 - if the term is related to a development product and confidentiality rules applies; • 2 - if the term has been proposed as a new term to the maintenance organisation but no official term has yet been assigned; • 3 - if the term has been accepted by the maintenance organisation as an official term.
localnumber	<p>The internal identification number shall be specified for a pharmaceutical dose form.</p> <p>The field is mandatory for the "Insert" operation.</p>

Data element name	Data element description
ev_code	<p>The Eudravigilance Code (EV Code) of the route of administration shall be provided.</p> <p>The field is mandatory if the operation type is not an insert.</p>
name_admroute	<p>The name of the route of administration in English shall be provided.</p>
versiondateformat	<p>Format of the Version Date shall be specified.</p> <p>It shall conform to the format "CCYYMMDD".</p>
versiondate	<p>Version Date of the list shall be specified.</p> <p>It shall conform to the format "CCYYMMDD".</p>
previous_ev_code	<p>The EVCode of a "development" route of administration shall be specified, where applicable.</p> <ul style="list-style-type: none"> • For a "proposed term", the EVcode the development term shall be specified, where applicable. • For an official term, the EVcode of the "proposed term" shall be specified, where applicable. • For a "development term" this is not applicable.
comment	<p>Further information may be supplied in the comment field.</p> <p>When the term information shall be nullified, the comment field is mandatory and the reason of nullification shall be provided.</p>
<p>developmentproducts</p> <p><i>See chapter 3.2.8.</i></p>	<p>The development product section</p> <p>This section shall be used to provide information on investigational medicinal products. It is not applicable to authorised medicinal products.</p>
developmentproduct	
localnumber	<p>The internal identification number shall be specified for a development product.</p> <p>The field is mandatory for the "Insert" operation.</p>
ev_code	<p>The Eudravigilance Code (EV Code) of the development product shall be provided.</p> <p>The field is mandatory if the operation type is NOT an "Insert" operation.</p>

Data element name	Data element description
senderlocalcode	The local code of the sender shall be specified.
sponsorcode	<p>The code of the sponsor shall be specified.</p> <p>The sponsor code shall have an attribute 'Resolution Mode':</p> <ul style="list-style-type: none"> Resolution mode 1 when the code is a Local Number; this is mandatory if the operation type is NOT "Insert". Resolution mode 2 when the code is an ev_code; this is mandatory if the operation type is NOT "Insert".
developmentpresentationname	The Development Product Section
productcode	The code of the development product as assigned by the sponsor shall be specified, where applicable.
productname	The name of the development product as assigned by the sponsor shall be specified, where applicable.
productothername	Other names assigned to the development product shall be specified, where applicable.
productatc	The product ATC classification system section
atccode	<p>The ATC code for the development product shall be specified.</p> <p>The ATC code must have an attribute 'Resolution Mode':</p> <ul style="list-style-type: none"> Resolution mode 1 when the code is a Local Number; this is mandatory if the operation type is NOT "Insert". Resolution mode 2 when the code is an ev_code; this is mandatory if the operation type is NOT "Insert".
productindication	<p>The indication(s) of the development medicinal product section</p> <p>The indication(s) of the development medicinal product shall be provided.</p> <p>The indication(s) shall be coded in MedDRA.</p>
meddraversion	The MedDRA version shall be specified (e.g. 13.0, 13.1, 14.0, cont.).
meddralevel	The level of the MedDRA terminology applied for the coding of the indication shall be specified.
meddracode	The MedDRA code for the coded indication shall be specified.

Data element name	Data element description
<i>pharmaceuticalproduct</i>	<p>The pharmaceutical product section</p> <p>The pharmaceutical product refers to the qualitative and quantitative composition of a medicinal product in the dose form approved for administration in line with the regulated product information.</p> <p>NOTE: A medicinal product may contain one or more pharmaceutical products.</p>
pharmaceuticalformcode	<p>The pharmaceutical dose form code of the pharmaceutical product shall be specified.</p> <p>The pharmaceutical dose form code must have an attribute 'Resolution Mode':</p> <ul style="list-style-type: none"> • Resolution mode 1 when the code is a Local Number; this is mandatory if the operation type is NOT "Insert". • Resolution mode 2 when the code is an ev_code; this is mandatory if the operation type is NOT "Insert".
productadminroutecode	<p>Information on the administration route(s) shall be provided.</p>
adminroutecode	<p>The route of administration code shall be specified.</p> <p>The pharmaceutical dose form code must have an attribute 'Resolution Mode':</p> <ul style="list-style-type: none"> • Resolution mode 1 when the code is a Local Number; this is mandatory if the operation type is NOT "Insert". • Resolution mode 2 when the code is an ev_code; this is mandatory if the operation type is NOT "Insert".
<i>activeingredient</i>	<p>The active ingredient section</p> <p>The active substance(s) of the medicinal product shall be specified.</p>
substancecode	<p>The substance code must have an attribute 'Resolution Mode':</p> <ul style="list-style-type: none"> • Resolution mode 1 when the code is a Local Number; this is mandatory if the operation type is NOT "Insert". • Resolution mode 2 when the code is an ev_code; this is mandatory if the operation type is NOT "Insert".

Data element name	Data element description
concentrationtypecode	<p>The code of the concentration type shall be specified (e.g. equal no, not less than).</p> <p>The concentration type code is mandatory for active substance (ingredient) and adjuvant.</p> <p>The concentration type code is optional for excipient.</p>
lowamountnumerunit	<p>The unit for the lower range numerator of the concentration shall be specified.</p> <p>The unit is mandatory for any substance where a concentration type code is given.</p>
lowamountnumerprefix	<p>The prefix for the unit for the lower range numerator of the concentration shall be specified (e.g. to allow for the use of Unified Codes for Units of Measure (UCUM)).</p> <p>The prefix for the unit is mandatory for any substance where a concentration type code is given.</p>
lowamountnumervalue	<p>The value for the lower range numerator of the concentration shall be specified.</p>
lowamountdenomunit	<p>The unit for the lower range denominator of the concentration shall be specified.</p> <p>The unit is mandatory for any substance where a concentration type code is given.</p>
lowamountdenomprefix	<p>The prefix for the unit for the lower range denominator of the concentration shall be specified (e.g. to allow for the use of Unified Codes for Units of Measure (UCUM)).</p> <p>The prefix for the unit is mandatory for any substance where a concentration type code is given.</p>
lowamountdenomvalue	<p>The value for the lower range denominator of the concentration shall be specified.</p>
highamountnumerunit	<p>The unit for the higher range numerator of the concentration shall be specified.</p> <p>The unit is mandatory for any substance where a concentration type code is given.</p>

Data element name	Data element description
highamountnumerprefix	<p>The prefix for the unit for the higher range numerator of the concentration shall be specified (e.g. to allow for the use of Unified Codes for Units of Measure (UCUM)).</p> <p>The prefix for the unit is mandatory for any substance where a concentration type code is given.</p>
highamountnumervalue	<p>The value for the higher range numerator of the concentration shall be specified.</p>
highamountdenomunit	<p>The unit for the higher range denominator of the concentration shall be specified.</p> <p>The unit is mandatory for any substance where a concentration type code is given.</p>
highamountdenomprefix	<p>The prefix for the unit for the higher range denominator of the concentration shall be specified (e.g. to allow for the use of Unified Codes for Units of Measure (UCUM)).</p> <p>The prefix for the unit is mandatory for any substance where a concentration type code is given.</p>
highamountdenomvalue	<p>The value for the higher range denominator of the concentration shall be specified.</p>
excipient	<p>The excipient section</p> <p>The excipient(s) of the medicinal product shall be specified.</p>
substancecode	<p>The substance code must have an attribute 'Resolution Mode':</p> <ul style="list-style-type: none"> • Resolution mode 1 when the code is a Local Number; this is mandatory if the operation type is NOT "Insert". • Resolution mode 2 when the code is an ev_code; this is mandatory if the operation type is NOT "Insert".
concentrationtypecode	<p>The code of the concentration type shall be specified (e.g. equal no, not less than).</p> <p>The concentration type code is mandatory for active substance (ingredient) and adjuvant.</p> <p>The concentration type code is optional for excipient.</p>

Data element name	Data element description
lowamountnumerunit	<p>The unit for the lower range numerator of the concentration shall be specified.</p> <p>The unit is mandatory for any substance where a concentration type code is given.</p>
lowamountnumerprefix	<p>The prefix for the unit for the lower range numerator of the concentration shall be specified (e.g. to allow for the use of Unified Codes for Units of Measure (UCUM)).</p> <p>The prefix for the unit is mandatory for any substance where a concentration type code is given.</p>
lowamountnumervalue	<p>The value for the lower range numerator of the concentration shall be specified.</p>
lowamountdenomunit	<p>The unit for the lower range denominator of the concentration shall be specified.</p> <p>The unit is mandatory for any substance where a concentration type code is given.</p>
lowamountdenomprefix	<p>The prefix for the unit for the lower range denominator of the concentration shall be specified (e.g. to allow for the use of Unified Codes for Units of Measure (UCUM)).</p> <p>The prefix for the unit is mandatory for any substance where a concentration type code is given.</p>
lowamountdenomvalue	<p>The value for the lower range denominator of the concentration shall be specified.</p>
highamountnumerunit	<p>The unit for the higher range numerator of the concentration shall be specified.</p> <p>The unit is mandatory for any substance where a concentration type code is given.</p>
highamountnumerprefix	<p>The prefix for the unit for the higher range numerator of the concentration shall be specified (e.g. to allow for the use of Unified Codes for Units of Measure (UCUM)).</p> <p>The prefix for the unit is mandatory for any substance where a concentration type code is given.</p>

Data element name	Data element description
highamountnumervalue	The value for the higher range numerator of the concentration shall be specified.
highamountdenomunit	<p>The unit for the higher range denominator of the concentration shall be specified.</p> <p>The unit is mandatory for any substance where a concentration type code is given.</p>
highamountdenomprefix	<p>The prefix for the unit for the higher range denominator of the concentration shall be specified (e.g. to allow for the use of Unified Codes for Units of Measure (UCUM)).</p> <p>The prefix for the unit is mandatory for any substance where a concentration type code is given.</p>
highamountdenomvalue	The value for the higher range denominator of the concentration shall be specified.
adjuvant	<p>The adjuvant section</p> <p>The adjuvant(s) of the medicinal product shall be specified, as applicable.</p>
substancecode	<p>The substance code must have an attribute 'Resolution Mode':</p> <ul style="list-style-type: none"> • Resolution mode 1 when the code is a Local Number; this is mandatory if the operation type is NOT "Insert". • Resolution mode 2 when the code is an ev_code; this is mandatory if the operation type is NOT "Insert".
concentrationtypecode	<p>The code of the concentration type shall be specified (e.g. equal no, not less than).</p> <p>The concentration type code is mandatory for active substance (ingredient) and adjuvant.</p> <p>The concentration type code is optional for excipient.</p>
lowamountnumerunit	<p>The unit for the lower range numerator of the concentration shall be specified.</p> <p>The unit is mandatory for any substance where a concentration type code is given.</p>

Data element name	Data element description
lowamountnumerprefix	<p>The prefix for the unit for the lower range numerator of the concentration shall be specified (e.g. to allow for the use of Unified Codes for Units of Measure (UCUM)).</p> <p>The prefix for the unit is mandatory for any substance where a concentration type code is given.</p>
lowamountnumervalue	<p>The value for the lower range numerator of the concentration shall be specified.</p>
lowamountdenomunit	<p>The unit for the lower range denominator of the concentration shall be specified.</p> <p>The unit is mandatory for any substance where a concentration type code is given.</p>
lowamountdenomprefix	<p>The prefix for the unit for the lower range denominator of the concentration shall be specified (e.g. to allow for the use of Unified Codes for Units of Measure (UCUM)).</p> <p>The prefix for the unit is mandatory for any substance where a concentration type code is given.</p>
lowamountdenomvalue	<p>The value for the lower range denominator of the concentration shall be specified.</p>
highamountnumerunit	<p>The unit for the higher range numerator of the concentration shall be specified.</p> <p>The unit is mandatory for any substance where a concentration type code is given.</p>
highamountnumerprefix	<p>The prefix for the unit for the higher range numerator of the concentration shall be specified (e.g. to allow for the use of Unified Codes for Units of Measure (UCUM)).</p> <p>The prefix for the unit is mandatory for any substance where a concentration type code is given.</p>
highamountnumervalue	<p>The value for the higher range numerator of the concentration shall be specified.</p>

Data element name	Data element description
highamountdenomunit	<p>The unit for the higher range denominator of the concentration shall be specified.</p> <p>The unit is mandatory for any substance where a concentration type code is given.</p>
highamountdenomprefix	<p>The prefix for the unit for the higher range denominator of the concentration shall be specified (e.g. to allow for the use of Unified Codes for Units of Measure (UCUM)).</p> <p>The prefix for the unit is mandatory for any substance where a concentration type code is given.</p>
highamountdenomvalue	<p>The value for the higher range denominator of the concentration shall be specified.</p>
medicaldevicecodes	<p>The medical device section</p> <p>The medical device(s) of the medicinal product shall be specified, where applicable</p>
medicaldevicecode	<p>The medical device code shall be specified.</p>
comment	<p>Additional information can be provided if required.</p>
ppiattachment	<p>The section shall refer to the product information that is provided.</p>
attachmentreference	<p>The document reference number of the product information shall be specified.</p> <p>The attachment reference must have an attribute 'Resolution Mode':</p> <ul style="list-style-type: none"> • Resolution mode 1 when the code is a Local Number; this is mandatory if the operation type is NOT "Insert". • Resolution mode 2 when the code is an ev_code; this is mandatory if the operation type is NOT "Insert".
validitydeclaration	<p>In performing an update of existing medicinal product where a PPI was already previously loaded and referenced, a confirmation shall be provided that the referenced PPI is the latest version of the documentation.</p> <p>The value is 1 if the PPI is the latest version.</p>

Data element name	Data element description
<p>authorisedproducts</p> <p>See chapter 3.2.9.</p>	<p>The authorised medicinal product section</p> <p>This section shall be applied for information on medicinal products authorised or registered in the EU.</p>
authorisedproduct	
localnumber	<p>The internal identification number shall be specified for an authorised medicinal product.</p> <p>The field is mandatory for the "Insert" operation.</p>
ev_code	<p>The Eudravigilance Code (EV Code) of the authorised medicinal product shall be provided.</p> <p>The field is mandatory if the operation type is NOT an "Insert" operation.</p>
newownerid	<p>The organisation identifier for a new marketing authorisation holder shall be specified, where applicable.</p> <p>This applies only to the operation type "Change of Ownership" (e.g. transfer of a marketing authorisation).</p>
mahcode	<p>The code of the marketing authorisation holder shall be specified.</p> <p>The sponsor code shall have an attribute 'Resolution Mode':</p> <ul style="list-style-type: none"> • Resolution mode 1 when the code is a Local Number; this is mandatory if the operation type is NOT "Insert". • Resolution mode 2 when the code is an ev_code; this is mandatory if the operation type is NOT "Insert".
senderlocalcode	The local code of the sender shall be specified.
infodateformat	<p>The date format shall be specified and conform to the format "CCYYMMDD".</p> <p>This refers to the date format of the latest version of the product information.</p>
infodate	<p>The date shall be specified and conform to the format "CCYYMMDD".</p> <p>This refers to the date of the latest version of the product information.</p>
authorisation	<p>Marketing authorisation and status section</p> <p>Information on the marketing authorisation and the marketing status shall be specified in this section.</p>

Data element name	Data element description
authorisationcountrycode	The code of the country where the medicinal product is authorised shall be specified.
authorisationprocedure	The authorisation procedure of the medicinal product shall be specified.
authorisationstatus	The status of the marketing authorisation shall be specified.
authorisationnumber	The marketing authorisation number of the medicinal product shall be specified.
authorisationdate	The date when the marketing authorisation was granted shall be specified.
authorisationdateformat	The date format for the marketing authorisation shall be provided and conform to the format "CCYYMMDD" or "CCYYMM".
mrpnumber	Where the medicinal product was subject to a mutual recognition or decentralised authorisation procedure, the MR number shall be specified.
eunumber	Where the medicinal product was authorised through the centralised procedure, the EU number shall be specified.
orphandrug	If the medicinal product has an orphan drug designation, this shall be specified.
intensivemonitoring	If the medicinal product is subject to intensive monitoring, this shall be specified.
withdrawnformat	If a medicinal product has been withdrawn from the market, the date shall be specified. The date format shall be specified and conform to the format "CCYYMMDD"
withdrawndate	If a medicinal product has been withdrawn from the market, the date shall be specified. The date shall be specified and conform to the format "CCYYMMDD".
<i>presentationname</i>	The medicinal product name section. The full and complete authorised medicinal product name in a jurisdiction shall be specified including a representation of the name part elements.
productname	The full and complete medicinal product name as approved shall be specified.
productshortname	The invented name of the medicinal product shall be specified, if applicable.
productgenericname	The common (generic) name of the medicinal product shall be specified, if applicable.

Data element name	Data element description
productcompanyname	The trademark if reflected in the medicinal product name shall be specified, if applicable.
productstrength	The strength, if reflected in the medicinal product name, shall be specified, if applicable.
productform	The pharmaceutical dose form, if reflected in the medicinal product name, shall be specified, if applicable.
packagedesc	A description of the package shall be specified.
<i>productatc</i>	The ATC code section for the medicinal product
atccode	<p>The ATC code of the authorised medicinal product shall be specified.</p> <p>The ATC code must have an attribute 'Resolution Mode':</p> <ul style="list-style-type: none"> • Resolution mode 1 when the code is a Local Number; this is mandatory if the operation type is NOT "Insert". • Resolution mode 2 when the code is an ev_code; this is mandatory if the operation type is NOT "Insert".
<i>productindication</i>	<p>The indication(s) of the development medicinal product section</p> <p>The indication(s) of the development medicinal product shall be provided.</p> <p>The indication(s) shall be coded in MedDRA.</p>
meddraversion	The MedDRA version shall be specified (e.g. 13.0, 13.1, 14.0, cont.).
meddralevel	The level of the MedDRA terminology applied for the coding of the indication shall be specified.
meddracode	The MedDRA code for the coded indication shall be specified.
<i>pharmaceuticalproduct</i>	<p>The pharmaceutical product section</p> <p>The pharmaceutical product refers to the qualitative and quantitative composition of a medicinal product in the dose form approved for administration in line with the regulated product information.</p> <p>NOTE: A medicinal product may contain one or more pharmaceutical products.</p>

Data element name	Data element description
pharmaceuticalformcode	<p>The pharmaceutical dose form code of the pharmaceutical product shall be specified.</p> <ul style="list-style-type: none"> The pharmaceutical dose form code must have an attribute 'Resolution Mode': Resolution mode 1 when the code is a Local Number; this is mandatory if the operation type is NOT "Insert". Resolution mode 2 when the code is an ev_code; this is mandatory if the operation type is NOT "Insert".
productadminroutecode	Information on the administration route(s) shall be provided.
Adminroutecode	<p>The route of administration code shall be specified.</p> <p>The pharmaceutical dose form code must have an attribute 'Resolution Mode':</p> <ul style="list-style-type: none"> Resolution mode 1 when the code is a Local Number; this is mandatory if the operation type is NOT "Insert". Resolution mode 2 when the code is an ev_code; this is mandatory if the operation type is NOT "Insert".
activeingredient	<p>The active ingredient section</p> <p>The active substance(s) of the medicinal product shall be specified.</p>
Substancecode	<p>The substance code must have an attribute 'Resolution Mode':</p> <ul style="list-style-type: none"> Resolution mode 1 when the code is a Local Number; this is mandatory if the operation type is NOT "Insert". Resolution mode 2 when the code is an ev_code; this is mandatory if the operation type is NOT "Insert".
concentrationtypecode	<p>The code of the concentration type shall be specified (e.g. equal no, not less than).</p> <p>The concentration type code is mandatory for active substance (ingredient) and adjuvant.</p> <p>The concentration type code is optional for excipient.</p>

Data element name	Data element description
lowamountnumerunit	<p>The unit for the lower range numerator of the concentration shall be specified.</p> <p>The unit is mandatory for any substance where a concentration type code is given.</p>
lowamountnumerprefix	<p>The prefix for the unit for the lower range numerator of the concentration shall be specified (e.g. to allow for the use of Unified Codes for Units of Measure (UCUM)).</p> <p>The prefix for the unit is mandatory for any substance where a concentration type code is given.</p>
lowamountnumervalue	<p>The value for the lower range numerator of the concentration shall be specified.</p>
lowamountdenomunit	<p>The unit for the lower range denominator of the concentration shall be specified.</p> <p>The unit is mandatory for any substance where a concentration type code is given.</p>
lowamountdenomprefix	<p>The prefix for the unit for the lower range denominator of the concentration shall be specified (e.g. to allow for the use of Unified Codes for Units of Measure (UCUM)).</p> <p>The prefix for the unit is mandatory for any substance where a concentration type code is given.</p>
lowamountdenomvalue	<p>The value for the lower range denominator of the concentration shall be specified.</p>
highamountnumerunit	<p>The unit for the higher range numerator of the concentration shall be specified.</p> <p>The unit is mandatory for any substance where a concentration type code is given.</p>
highamountnumerprefix	<p>The prefix for the unit for the higher range numerator of the concentration shall be specified (e.g. to allow for the use of Unified Codes for Units of Measure (UCUM)).</p> <p>The prefix for the unit is mandatory for any substance where a concentration type code is given.</p>

Data element name	Data element description
highamountnumervalue	The value for the higher range numerator of the concentration shall be specified.
highamountdenomunit	<p>The unit for the higher range denominator of the concentration shall be specified.</p> <p>The unit is mandatory for any substance where a concentration type code is given.</p>
highamountdenomprefix	<p>The prefix for the unit for the higher range denominator of the concentration shall be specified (e.g. to allow for the use of Unified Codes for Units of Measure (UCUM)).</p> <p>The prefix for the unit is mandatory for any substance where a concentration type code is given.</p>
highamountdenomvalue	The value for the higher range denominator of the concentration shall be specified.
<i>excipient</i>	<p>The excipient section</p> <p>The excipient(s) of the medicinal product shall be specified.</p>
substancecode	<p>The substance code must have an attribute 'Resolution Mode':</p> <ul style="list-style-type: none"> • Resolution mode 1 when the code is a Local Number; this is mandatory if the operation type is NOT "Insert". • Resolution mode 2 when the code is an ev_code; this is mandatory if the operation type is NOT "Insert".
concentrationtypecode	<p>The code of the concentration type shall be specified (e.g. equal no, not less than).</p> <p>The concentration type code is mandatory for active substance (ingredient) and adjuvant.</p> <p>The concentration type code is optional for excipient.</p>
lowamountnumerunit	<p>The unit for the lower range numerator of the concentration shall be specified.</p> <p>The unit is mandatory for any substance where a concentration type code is given.</p>

Data element name	Data element description
lowamountnumerprefix	<p>The prefix for the unit for the lower range numerator of the concentration shall be specified (e.g. to allow for the use of Unified Codes for Units of Measure (UCUM)).</p> <p>The prefix for the unit is mandatory for any substance where a concentration type code is given.</p>
lowamountnumervalue	<p>The value for the lower range numerator of the concentration shall be specified.</p>
lowamountdenomunit	<p>The unit for the lower range denominator of the concentration shall be specified.</p> <p>The unit is mandatory for any substance where a concentration type code is given.</p>
lowamountdenomprefix	<p>The prefix for the unit for the lower range denominator of the concentration shall be specified (e.g. to allow for the use of Unified Codes for Units of Measure (UCUM)).</p> <p>The prefix for the unit is mandatory for any substance where a concentration type code is given.</p>
lowamountdenomvalue	<p>The value for the lower range denominator of the concentration shall be specified.</p>
highamountnumerunit	<p>The unit for the higher range numerator of the concentration shall be specified.</p> <p>The unit is mandatory for any substance where a concentration type code is given.</p>
highamountnumerprefix	<p>The prefix for the unit for the higher range numerator of the concentration shall be specified (e.g. to allow for the use of Unified Codes for Units of Measure (UCUM)).</p> <p>The prefix for the unit is mandatory for any substance where a concentration type code is given.</p>
highamountnumervalue	<p>The value for the higher range numerator of the concentration shall be specified.</p>

Data element name	Data element description
highamountdenomunit	<p>The unit for the higher range denominator of the concentration shall be specified.</p> <p>The unit is mandatory for any substance where a concentration type code is given.</p>
highamountdenomprefix	<p>The prefix for the unit for the higher range denominator of the concentration shall be specified (e.g. to allow for the use of Unified Codes for Units of Measure (UCUM)).</p> <p>The prefix for the unit is mandatory for any substance where a concentration type code is given.</p>
highamountdenomvalue	<p>The value for the higher range denominator of the concentration shall be specified.</p>
adjuvant	<p>The adjuvant section</p> <p>The adjuvant(s) of the medicinal product shall be specified, as applicable.</p>
substancecode	<p>The substance code must have an attribute 'Resolution Mode':</p> <ul style="list-style-type: none"> • Resolution mode 1 when the code is a Local Number; this is mandatory if the operation type is NOT "Insert". • Resolution mode 2 when the code is an ev_code; this is mandatory if the operation type is NOT "Insert".
concentrationtypecode	<p>The code of the concentration type shall be specified (e.g. equal no, not less than).</p> <p>The concentration type code is mandatory for active substance (ingredient) and adjuvant.</p> <p>The concentration type code is optional for excipient.</p>
lowamountnumerunit	<p>The unit for the lower range numerator of the concentration shall be specified.</p> <p>The unit is mandatory for any substance where a concentration type code is given.</p>

Data element name	Data element description
lowamountnumerprefix	<p>The prefix for the unit for the lower range numerator of the concentration shall be specified (e.g. to allow for the use of Unified Codes for Units of Measure (UCUM)).</p> <p>The prefix for the unit is mandatory for any substance where a concentration type code is given.</p>
lowamountnumervalue	<p>The value for the lower range numerator of the concentration shall be specified.</p>
lowamountdenomunit	<p>The unit for the lower range denominator of the concentration shall be specified.</p> <p>The unit is mandatory for any substance where a concentration type code is given.</p>
lowamountdenomprefix	<p>The prefix for the unit for the lower range denominator of the concentration shall be specified (e.g. to allow for the use of Unified Codes for Units of Measure (UCUM)).</p> <p>The prefix for the unit is mandatory for any substance where a concentration type code is given.</p>
lowamountdenomvalue	<p>The value for the lower range denominator of the concentration shall be specified.</p>
highamountnumerunit	<p>The unit for the higher range numerator of the concentration shall be specified.</p> <p>The unit is mandatory for any substance where a concentration type code is given.</p>
highamountnumerprefix	<p>The prefix for the unit for the higher range numerator of the concentration shall be specified (e.g. to allow for the use of Unified Codes for Units of Measure (UCUM)).</p> <p>The prefix for the unit is mandatory for any substance where a concentration type code is given.</p>
highamountnumervalue	<p>The value for the higher range numerator of the concentration shall be specified.</p>

Data element name	Data element description
highamountdenomunit	<p>The unit for the higher range denominator of the concentration shall be specified.</p> <p>The unit is mandatory for any substance where a concentration type code is given.</p>
highamountdenomprefix	<p>The prefix for the unit for the higher range denominator of the concentration shall be specified (e.g. to allow for the use of Unified Codes for Units of Measure (UCUM)).</p> <p>The prefix for the unit is mandatory for any substance where a concentration type code is given.</p>
highamountdenomvalue	The value for the higher range denominator of the concentration shall be specified.
<i>medicaldevicecodes</i>	<p>The medical device section</p> <p>The medical device(s) of the medicinal product shall be specified, where applicable</p>
medicaldevicecode	The medical device code shall be specified.
<i>previous_ev_codes</i>	<p>The previous EV Code section</p> <p>This section shall be used when the authorised medicinal product shall be linked to the EVcode of a development product.</p>
previous_ev_code	The EVCode of the development product shall be specified, if applicable.
comment	<p>Further information may be supplied in the comment field.</p> <p>When the term information shall be nullified, the comment field is mandatory and the reason of nullification shall be provided.</p>
<i>ppiattachment</i>	The section shall refer to the product information that is provided.
attachmentreference	<p>The document reference number of the product information shall be specified.</p> <p>The attachment reference must have an attribute 'Resolution Mode':</p> <ul style="list-style-type: none"> • Resolution mode 1 when the code is a Local Number; this is mandatory if the operation type is NOT "Insert". • Resolution mode 2 when the code is an ev_code; this is mandatory if the operation type is NOT "Insert".

Data element name	Data element description
validitydeclaration	<p>In performing an update of existing EVMPD medicinal product where a PPI was already previously loaded and referenced, a confirmation shall be provided that the referenced PPI is the latest version of the documentation.</p> <p>The value is 1 if the PPI is the latest version.</p>
<p>attachments</p> <p>See chapter 3.2.10.</p>	The attachment section
attachment	<p>An electronic copy of the product information as applicable, shall be provided:</p> <ul style="list-style-type: none"> - Summary of Product Characteristics - Manufacturing Authorisation Holder responsible for Batch Release - Conditions of the Marketing Authorisation - Labelling - Package Leaflet
localnumber	The local number of the attachment shall be specified.
filename	The file name of the attached product information shall be provided.
filetype	<p>The file type of the attached product information shall be provided.</p> <p>Currently only PDF (value = 1) is allowed.</p>
attachmentname	The name of the attachment shall be specified.
attachmenttype	<p>The Type of attachment shall be specified.</p> <p>Currently only PPI (value = 1) is allowed</p>
languagecode	The code of the language applicable to the attachment shall be specified.
attachmentversion	The version of the attachment shall be specified.
attachmentversiondate	The date of the last update of the product information shall be specified.
versiondateformat	The date format for the version of the product information shall be provided and conform to the format "CCYYMMDD"
<p>qppvs</p> <p>See chapter 3.2.11.</p>	<p>The QPPV section</p> <p>This section refers to the name and the contact details of the Qualified Person Responsible for Pharmacovigilance (QPPV).</p>
qppv	The name and contact details of the QPPV shall be specified in this section.

Data element name	Data element description
localnumber	<p>The internal identification number shall be specified by the MAH.</p> <p>The field is mandatory for the "Insert" operation.</p>
ev_code	<p>The EVcode shall be specified.</p> <p>An EVcode is assigned to every new organisation.</p> <p>This field is mandatory if the operation type is NOT "Insert".</p>
qppvfamilyname	The family name of the QPPV shall be specified.
qppvgivenname	The given name of the QPPV shall be specified.
qppvtitle	The title of the QPPV shall be specified.
qppvcompany	The name of the company, where the QPPV is employed shall be specified.
qppvdepartment	The name of the department of the QPPV shall be specified.
qppvbuilding	The name of the building of the location of the QPPV shall be specified.
qppvstreet	The name of the street of the location of the QPPV shall be specified.
qppvcity	The city of the location of the QPPV shall be specified.
qppvstate	The state of the location of the QPPV shall be specified.
qppvpostcode	The postcode of the location of the QPPV shall be specified.
qppvcountrycode	The country code of the location of the QPPV shall be specified.
qppvtelcountrycode	The country code of the phone number of the QPPV shall be specified.
qppvtelnumber	The phone number of the QPPV shall be specified.
qppvtelextn	The extension of the phone number of the QPPV shall be specified.
qppvcellcountrycode	The country code of the cell phone number of the QPPV shall be specified.
qppvcellnumber	The cell phone number of the QPPV shall be specified.
qppvfaxcountrycode	The country code of the fax number of the QPPV shall be specified.
qppvfaxnumber	The fax number of the QPPV shall be specified.
qppvfaxextn	The extension of the fax number of the QPPV shall be specified.
qppvemail	The email address of the QPPV shall be specified.
<p>masterfilelocations</p> <p>See chapter 3.2.12.</p>	<p>The Pharmacovigilance System Master File location section</p> <p>This section refers to the location of the master file.</p>
<p>masterfilelocation</p>	This section specifies the location of the master file.
localnumber	<p>The internal identification number shall be specified by the MAH.</p> <p>The field is mandatory for the "Insert" operation.</p>

Data element name	Data element description
ev_code	The EVcode shall be specified. An EVcode is assigned to every new organisation. This field is mandatory if the operation type is NOT "Insert".
mflcompany	The name of the company, where the master file is located, shall be specified.
mfldepartment	The name of the department where the master file is located shall be specified.
mflbuilding	The name of the building where the master file is located shall be specified.
mflstreet	The name of the street where the master file is located shall be specified.
mflcity	The city where the master file is located shall be specified.
mflstate	The state where the master file is located shall be specified.
mflpostcode	The postcode where the master file is located shall be specified.
mflcountrycode	The country code where the master file is located shall be specified.

4. Structured Substance Information

Structured Substance Information (SSI) refers to data elements presented in an XML file that contains detailed characteristics of the substance(s), which are ingredients of medicinal products.

An SSI file shall be created for each substance, which is an ingredient of a medicinal product. The SSI file is incorporated in the EVPRM as outlined in chapter 3.3.

The set of characteristics that shall be provided in the SSI are based on the type of substance class specified in the EVPRM. The classification of the substance shall be based on the principles outlined in chapter 6.

4.1. The Structured Substance Information overview

The characteristics to be defined for each substance class are specified in the chapters 4.2.1. - 4.2.9.

Depending on the nature of the substance, each substance shall be described based on the following substance classes:

- Chemical - characteristics are outlined in chapter 4.2.1.
- Nucleic Acid - characteristics are outlined in chapter 4.2.2.
- Polymer - characteristics are outlined in chapter 4.2.3.
- Protein - characteristics are outlined in chapter 4.2.4.
- Structurally Diverse Substance – characteristics are outlined in chapter 4.2.5.

- Mixture - characteristics are outlined in chapter 4.2.6.
- Specified Substance – Group 1 - characteristics are outlined in chapter 4.2.7.
- Specified Substance – Group 2 - characteristics are outlined in chapter 4.2.8.
- Specified Substance – Group 3 - characteristics are outlined in chapter 4.2.9.

4.1.1. The Structred Substance Information chemicals

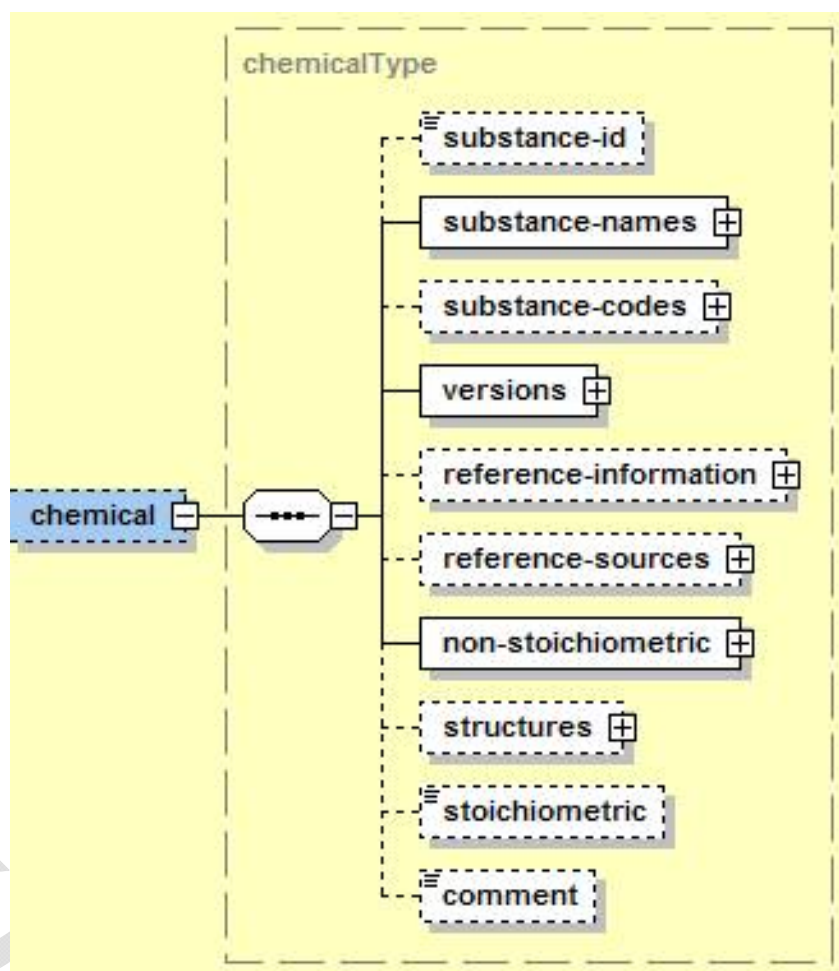

Figure 20 - EVPRM –Structured Substance Information (SSI) Chemicals

4.1.2. The Structured Substance Information nucleic acid

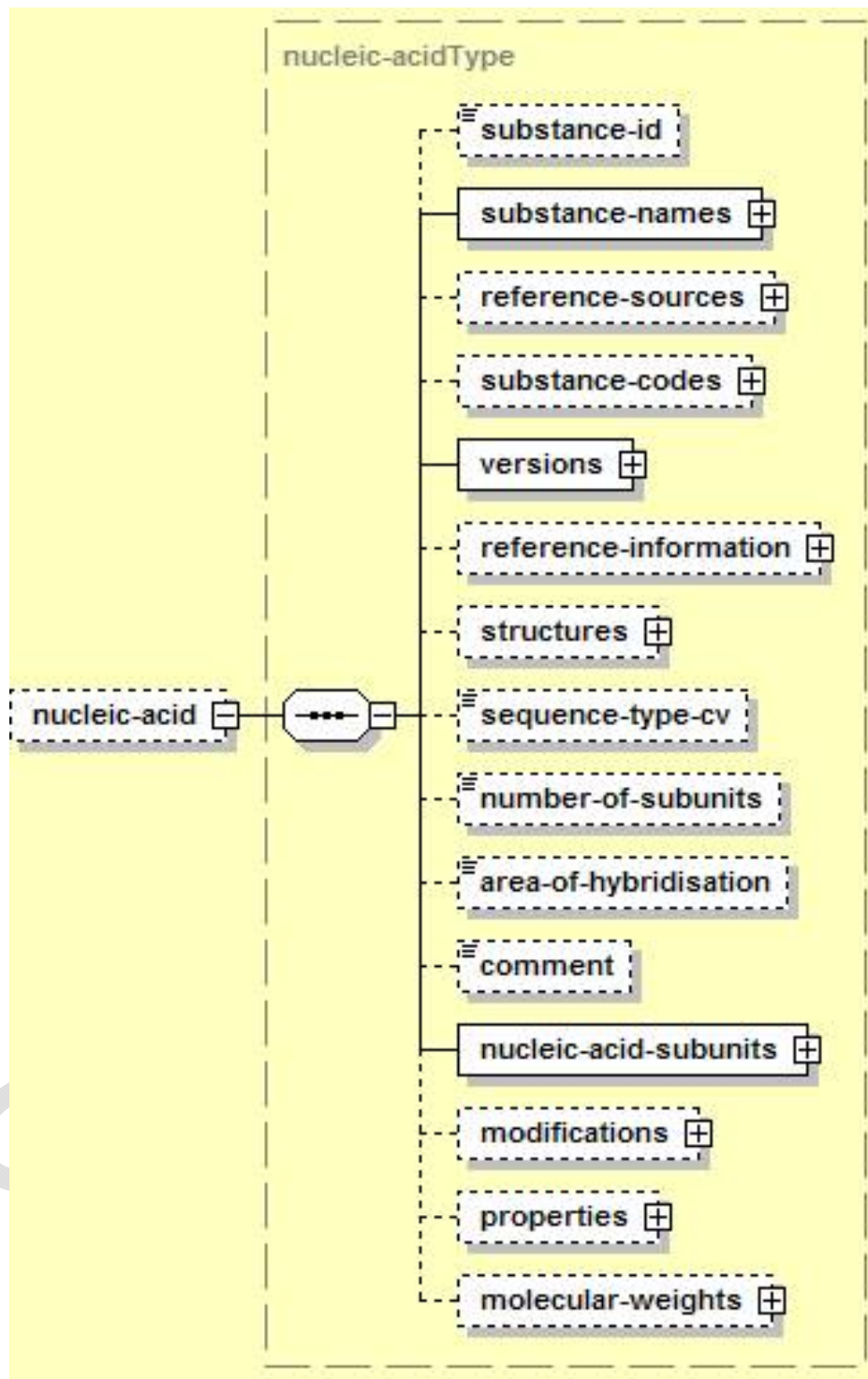

Figure 21 - EVPRM –Structured Substance Information (SSI) Nucleic Acids

4.1.3. The Structured Substance Information polymers

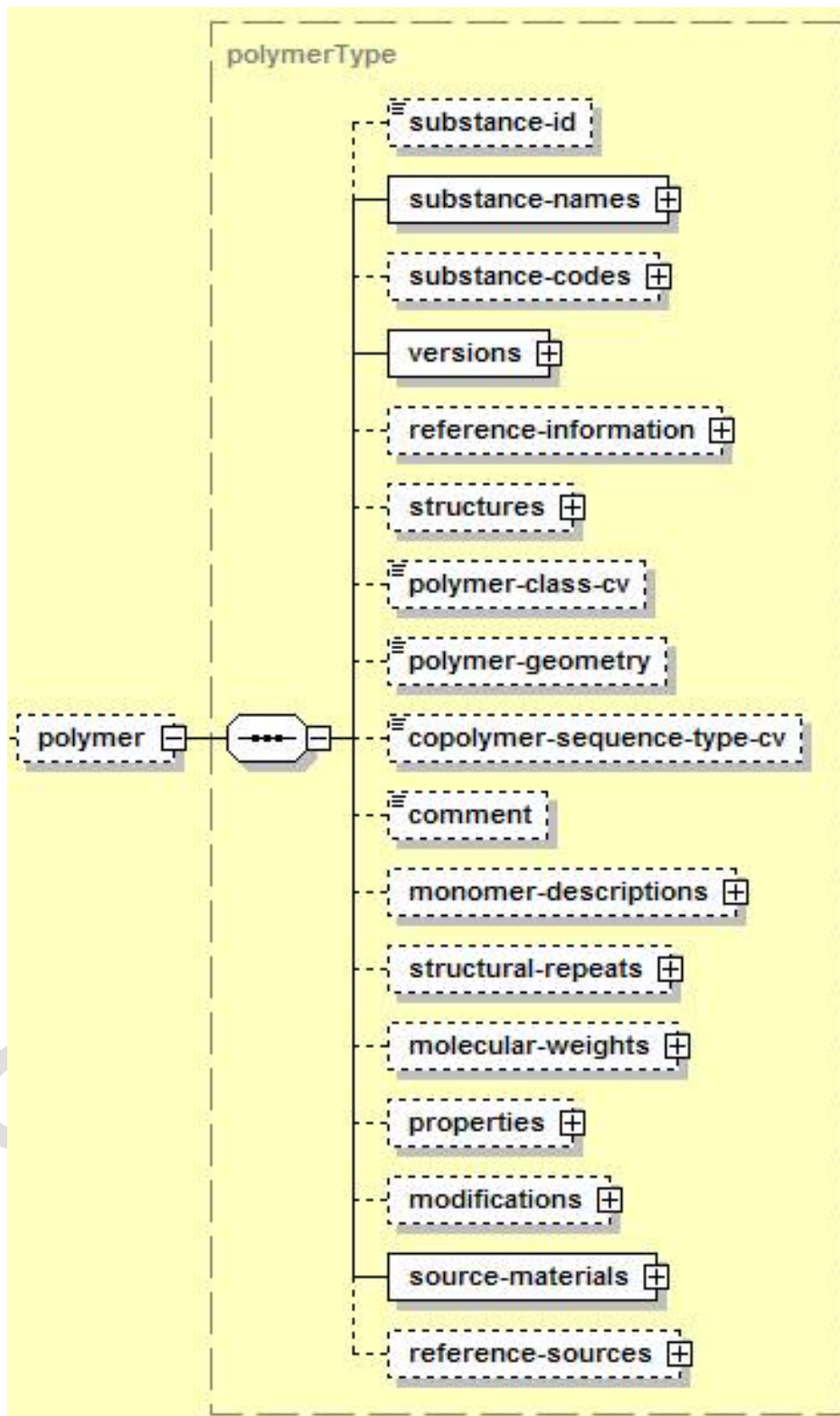

Figure 22 - EVPRM –Structured Substance Information (SSI) Polymers

4.1.4. The Structured Substance Information proteins

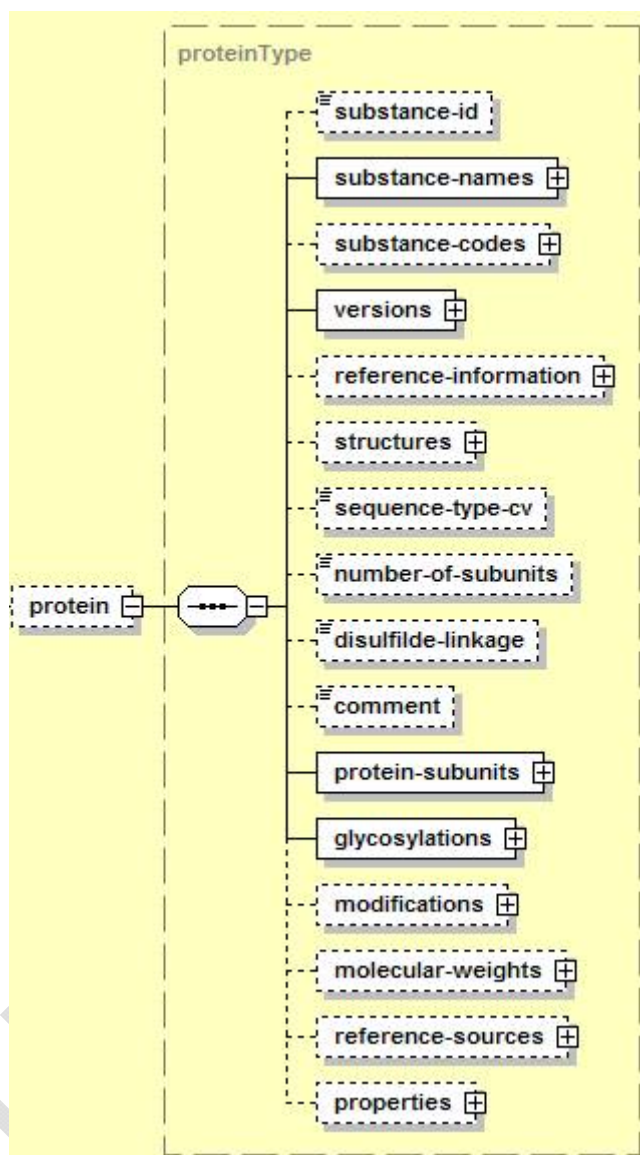

Figure 23 - EVPRM –Structured Substance Information (SSI) Proteins

4.1.5. The Structured Substance Information structurally diverse substances

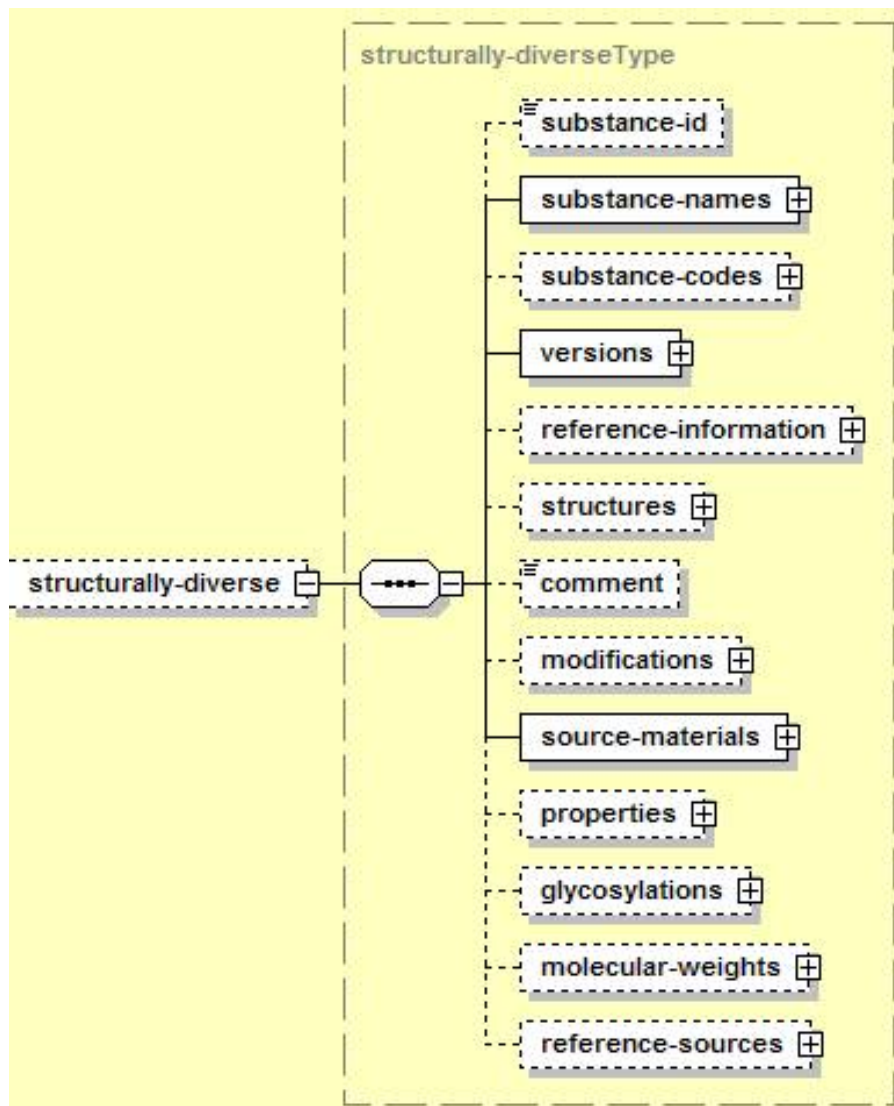

Figure 24 - EVPRM –Structured Substance Information (SSI) Structurally Diverse Substances

4.1.6. The Structured Substance Information mixtures

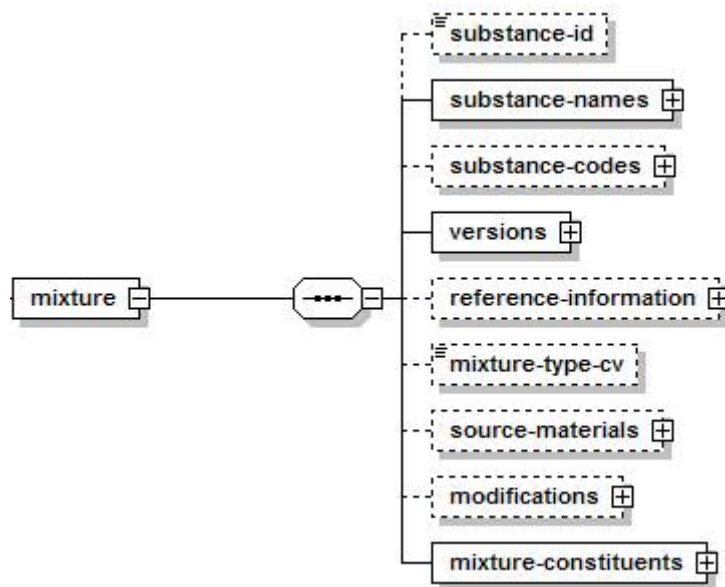

Figure 25 - EVPRM –Structured Substance Information (SSI) Mixtures

4.1.7. The Structured Substance Information specified substance group 1

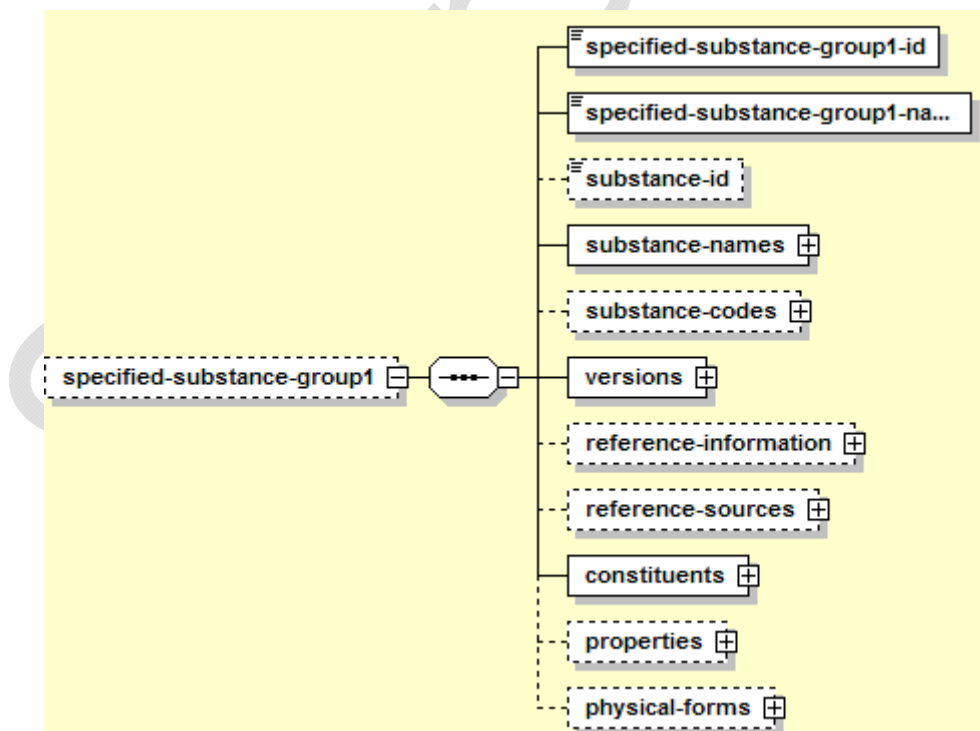

Figure 26 - EVPRM –Structured Substance Information (SSI) Specified Substance Group 1

4.1.8. The Structured Substance Information specified substance group 2

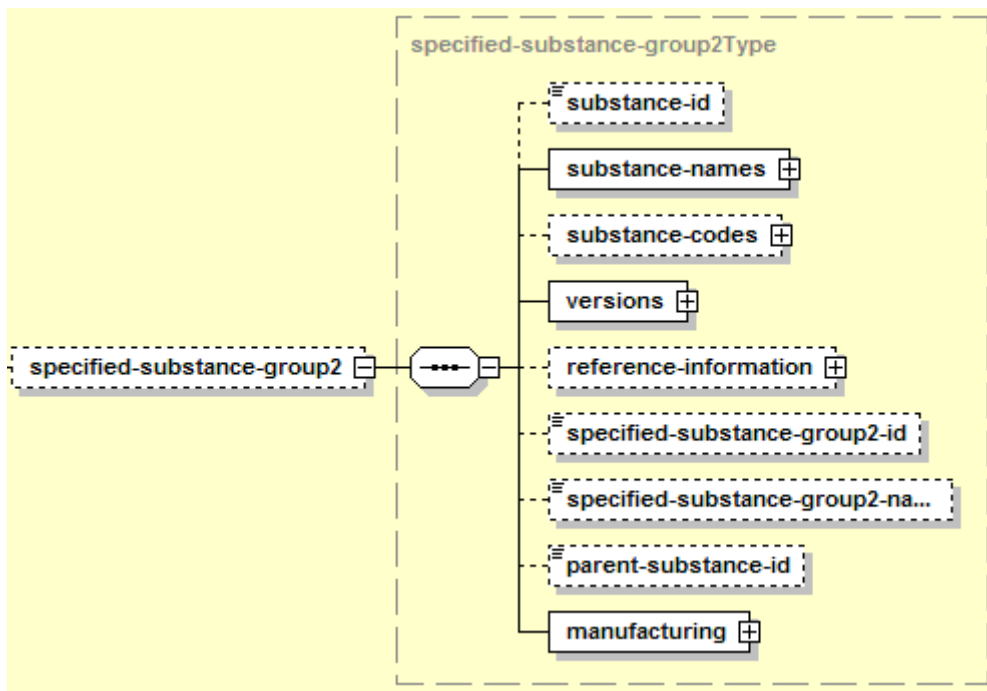

Figure 27 - EVPRM –Structured Substance Information (SSI) Specified Substance Group 2

4.1.9. The Structured Substance Information specified substance group 3

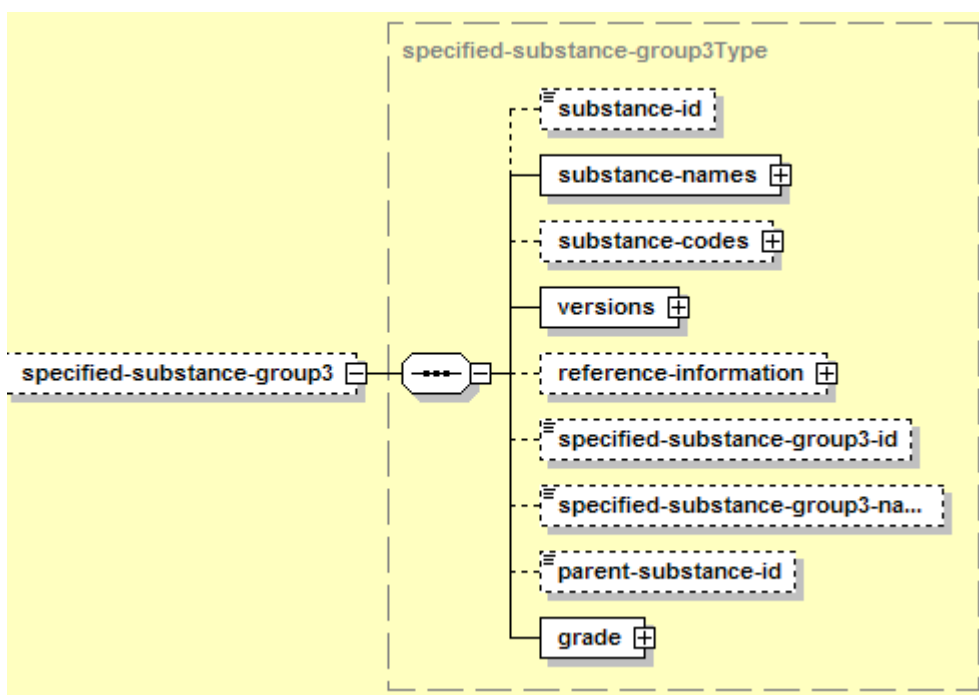

Figure 28 - EVPRM –Structured Substance Information (SSI) Specified Substance Group 3

4.2. The Structured Substance Information data element description

4.2.1. Structured Substance Information (SSI) for chemical substances

For chemical substances the SSI shall be based on the following data elements:

SSI level	Data element name	Data element description
substance		
	Substance ID	The unique identifier assigned to the substance.
substance_name		The substance name section This section contains the set of elements for the description of the name of the substance.
	Substance_name	The name of the substance shall be specified.

SSI level	Data element name	Data element description
	Substance_name_type	The type of the name shall be specified based on a controlled vocabulary. EXAMPLE: code, brand name, established name, primary name, other name.
	Language	The language of the substance name shall be specified according to ISO 639-2 alpha-3 codes.
official_name		The official name section
	Official_name_type	The type of the official name shall be specified based on a controlled vocabulary. EXAMPLE: USAN, INN, JAN, BAN, USP, EP, INCI, JECFA
	Official_name_status	The status of the official name shall be specified based on a controlled vocabulary. EXAMPLE: current, alternate, superceded, proposed
	Official_name_status_change_date	The change date of the status of the official name shall be specified in line with the ISO 8601 date format, which shall be only entered when name is changed.
official_name_domain		
	Official_name_domain	The domain of the name shall be provided based on a controlled vocabulary. EXAMPLE: biologic
official_name_jurisdiction		The jurisdiction of the official name section
	Official_name_jurisdiction	The jurisdiction of the official name shall be provided based on ISO 3166-1 alpha-2 codes with two exceptions: EL (not GR) is used to represent Greece, and UK (not GB) is used to represent the United Kingdom.
reference_source		The reference source section This section describes the reference source information.
	Public_domain	It shall be specified if the reference source information is public or not. Yes or No values apply.

SSI level	Data element name	Data element description
	Reference_source_type	The type of the reference source shall be specified based on a controlled vocabulary. EXAMPLE: INN
	Reference_source_class	The class of the reference source shall be specified based on a controlled vocabulary. EXAMPLE: public, regulatory submission
	Reference_source_id	The reference source identifier shall be specified.
	Reference_source_citation	The literature or regulatory document reference shall be described.
substance_code		The substance code section This section describes the code system(s) that apply to a substance.
	Code	The specific code with regard to a referenced code system shall be provided.
	Code_system	The code system shall be specified based on a controlled vocabulary EXAMPLE: CAS, EINECS, NSC, ASK, ATC, Ndf-Rt; Rx-Cui
	Code_system_id	The identifier for the code system shall be provided based on a controlled vocabulary.
	Code_system_status	The status of the code system shall be specified based on a controlled vocabulary. EXAMPLE: current, alternate, superceded.
	Code_system_change_date	The change date of the code system shall be specified in line with the ISO 8601 date format, where applicable. This shall be generated when the status changes.
	Comment	Any comment shall be provided in this field, if required.

SSI level	Data element name	Data element description
reference_source		The reference source section This section described the reference sources of the information.
	Public_domain	It shall be specified if the reference source information is public or not. Yes or No values apply.
	Reference_source_type	The type of the reference source shall be specified based on a controlled vocabulary.
	Reference_source_class	The class of the reference source shall be specified based on a controlled vocabulary. EXAMPLE: public, regulatory submission
	Reference_source_id	The reference source identifier shall be specified.
	Reference_source_citation	The literature or regulatory document reference shall be referenced.
version		The version section This section shall provide information on the version of the substance information.
	Version_number	The number of the version of the SSI shall be provided.
	Effective_date	The date when the SSI was effective shall be provided in line with the ISO 8601 date format. This shall be defined when the SSI is generated or modified.
	Change_made	The description of the updates or changes of the SSI shall be specified.
reference_informati on		The reference information section This section is used to provide details about the reference information.
	Comment	Additional information as regards the applicable references can be specified.
substance_classifica tion		The substance classification

SSI level	Data element name	Data element description
	Domain	The domain of the substance classification shall be provided based on a controlled vocabulary. EXAMPLE: vaccine, colorant, flavor
	Substance_classification	The substance classification shall be provided based on a controlled vocabulary. EXAMPLE: hmg-coeductase inhibitor
	Substance_classification_type	The type of the classification applied shall be provided based on a controlled vocabulary. EXAMPLE: WHO-ATC, NDF-RT
	Substance_classification_code	The code of the classification type shall be specified based on a controlled vocabulary. EXAMPLE: ATC code, NDF-RT code
subtype		The subtype section
	Substance_class_subtype	The sub-type of the classification shall be described based on a controlled vocabulary. EXAMPLE: human, viral, bacteria, fungal
reference_source		The reference source section This section described the reference sources of the information.
	Public_domain	It shall be specified if the reference source information is public or not. Yes or No values apply.
	Reference_source_type	The type of the reference source shall be specified based on a controlled vocabulary.
	Reference_source_class	The class of the reference source shall be specified based on a controlled vocabulary. EXAMPLE: public, regulatory submission
	Reference_source_id	The reference source identifier shall be specified.
	Reference_source_citation	The literature or regulatory document reference shall be referenced.

SSI level	Data element name	Data element description
substance_relationship		<p>The substance relationship</p> <p>This section shall provide information related to relationship of a substance, where this is applicable.</p>
	Relationship	<p>The relationship of a substance shall be defined based on a controlled vocabulary.</p> <p>EXAMPLE: active moiety, constituent, impurity, degradant, may contain, metabolite, target, transporter, metabolic enzyme, gene element, etc</p>
	Interaction_type	<p>The type of interaction shall be specified based on a controlled vocabulary, where applicable.</p> <p>EXAMPLE: substrate, agonist, partial agonist, antagonist</p>
	Substance_id	The substance identifier, for which the relationship is specified, shall be described.
	Substance_name	The substance name shall be specified.
	Amount_type	<p>The type of the amount of the substance shall be specified using a controlled vocabulary.</p> <p>EXAMPLE: mole ratio, weight percent</p>
amount		The amount section
	Average	The average amount or single value of the substance shall be specified.
	Low_limit	The lower limit of the substance shall be specified, where available.
	High_limit	The higher limit of the substance shall be specified, where available.
	Unit	The applicable unit for the amount shall be specified.
	Non_numeric_value	The non numeric value shall be specified based on a controlled vocabulary.
reference_source		<p>The reference source section</p> <p>This section described the reference sources of the information.</p>

SSI level	Data element name	Data element description
	Public_domain	It shall be specified if the reference source information is public or not. Yes or No values apply.
	Reference_source_type	The type of the reference source shall be specified based on a controlled vocabulary.
	Reference_source_class	The class of the reference source shall be specified based on a controlled vocabulary. EXAMPLE: public, regulatory submission
	Reference_source_id	The reference source identifier shall be specified.
	Reference_source_citation	The literature or regulatory document reference shall be referenced.
Gene		The gene section This section shall provide a description of the gene in relation to a substance, where applicable.
	Gene_sequence_origin	The common name for the organism from which the final gene sequence originated shall be specified; this applies primarily to proteins.
	Gene_id	The identifier of the gene shall be provided.
	Gene_name	The complete name given for a gene shall be provided.
reference_source		The reference source section This section described the reference sources of the information.
	Public_domain	It shall be specified if the reference source information is public or not. Yes or No values apply.
	Reference_source_type	The type of the reference source shall be specified based on a controlled vocabulary.

SSI level	Data element name	Data element description
	Reference_source_class	The class of the reference source shall be specified based on a controlled vocabulary. EXAMPLE: public, regulatory submission
	Reference_source_id	The reference source identifier shall be specified.
	Reference_source_citation	The literature or regulatory document reference shall be referenced.
Gene_element		The gene element section
	Gene_element_type	The type of the gene element shall be specified based on a controlled vocabulary. EXAMPLE: enhancer, promoter, silencer, terminator, repressor (..)
	Gene_element_id	The unique identifier for the gene element shall be specified based on a controlled vocabulary.
	Gene_element_name	The specific gene element name shall be described based on a controlled vocabulary.
reference_source		The reference source section This section described the reference sources of the information.
	Public_domain	It shall be specified if the reference source information is public or not. Yes or No values apply.
	Reference_source_type	The type of the reference source shall be specified based on a controlled vocabulary.
	Reference_source_class	The class of the reference source shall be specified based on a controlled vocabulary. EXAMPLE: public, regulatory submission
	Reference_source_id	The reference source identifier shall be specified.
	Reference_source_citation	The literature or regulatory document reference shall be referenced.

SSI level	Data element name	Data element description
target		The target section This section shall provide information on the target substance.
	Target_gene_id	The identifier of the target gene shall be provided.
	Target_gene_name	The target gene name shall be specified based on a controlled vocabulary. EXAMPLE: single substance, a pathway, an enzyme type
	Interaction_type	The type of interaction shall be specified based on a controlled vocabulary. EXAMPLE: inhibitor, inducer
	Target_organism_type	The type of target organism shall be specified based on a controlled vocabulary. EXAMPLE: human, viral, bacteria, fungal
	Target_type	The target type shall be specified based on a controlled vocabulary. EXAMPLE: enzyme, receptor, membrane
	reference_source	
Public_domain		It shall be specified if the reference source information is public or not. Yes or No values apply.
Reference_source_type		The type of the reference source shall be specified based on a controlled vocabulary.
Reference_source_class		The class of the reference source shall be specified based on a controlled vocabulary. EXAMPLE: public, regulatory submission
Reference_source_id		The reference source identifier shall be specified.
Reference_source_citation		The literature or regulatory document reference shall be referenced.

SSI level	Data element name	Data element description
structure		The structure section The structure of the substance shall be described, where applicable
	Structural_representation_type	The type of the structural representation shall be described based on a controlled vocabulary. EXAMPLE: inchi, mol file
	Structural_representation	The structural representation shall be provided.
	Structural_representation_attachment	A copy of the structural representation shall be provided.
	Stereochemistry	The stereochemistry of the substance shall be described based on a controlled vocabulary. EXAMPLE: racemic; meso; mixed; unknown; axial, absolute; achiral (cis/trans or geometric isomerism indicated in structure)
	Optical_activity	The optical activity shall be described based on a controlled vocabulary. EXAMPLE: (+), (-), (+/-)
	Molecular_formula	The molecular formula shall be provided.
		The isotope section The isotope shall be described in this section, where applicable.
isotope	Nuclide_id	The identifier for each nuclide shall be provided based on a controlled vocabulary.
	Nuclide_name	The name for the nuclide shall be provided.
	Substitution_type	The type of substitution shall be described using a controlled vocabulary. EXAMPLE: specific; non-specific; unknown

SSI level	Data element name	Data element description
chemical		<p>The chemical substance section</p> <p>This section further defines the identifying characteristics of a chemical substance.</p>
	Stoichiometric	The stoichiometric characteristics shall be specified based on a controlled vocabulary.
	Comment	Further information related to the substance may be provided.
reference_source		<p>The reference source section</p> <p>This section described the reference sources of the information.</p>
	Public_domain	It shall be specified if the reference source information is public or not. Yes or No values apply.
	Reference_source_type	The type of the reference source shall be specified based on a controlled vocabulary.
	Reference_source_class	<p>The class of the reference source shall be specified based on a controlled vocabulary.</p> <p>EXAMPLE: public, regulatory submission</p>
	Reference_source_id	The reference source identifier shall be specified.
	Reference_source_citation	The literature or regulatory document reference shall be referenced.
non_stoichiometric		<p>The non-stoichiometric section</p> <p>This section applies when the substance is not stoichiometric.</p>
	Number_of_moieties	<p>Non-stoichiometric chemical substances shall have at least two moieties. Each moiety shall be represented by a chemical structure.</p> <p>The number of moieties specified shall be provided.</p>

SSI level	Data element name	Data element description
property		The property section This section provides the property characteristics of the substance.
	Property_type	The type of property shall be specified based on a controlled vocabulary. EXAMPLE: physical, chemical, enzymatic, immunological
	Property_name	The name of the property shall be specified.
	Substance_id	The identifier of the substance related to a defining property shall be described. EXAMPLE: for cell surface antigens, the substance identifier for cd4 is captured to define cd4 positive cells
	Substance_name	The name of the substance related to a defining property shall be described. EXAMPLE: for cell surface antigens
	Amount_type	The type of the amount based on a controlled vocabulary shall be specified as applicable. EXAMPLE: mole ratio, weight percent
amount		The amount section
	Average	The average amount or single value of the substance shall be specified.
	Low_limit	The lower limit of the substance shall be specified, where available.
	High_limit	The higher limit of the substance shall be specified, where available.
	Unit	The applicable unit for the amount shall be specified.
	Non_numeric_value	The non numeric value shall be specified based on a controlled vocabulary.
moiety		The moiety section
	Moiety_Role	The role of the moiety shall be described based on a controlled vocabulary. EXAMPLE: antigen, linker, conjugate

SSI level	Data element name	Data element description
	Moiety_id	The unique identifier of the moiety shall be provided.
	Moiety_name	The name of the moiety shall be provided.
	Amount_type	The type of the amount based on a controlled vocabulary shall be specified. EXAMPLE: mole ratio, weight percent
amount		The amount section
	Average	The average amount or single value of the substance shall be specified.
	Low_limit	The lower limit of the substance shall be specified, where available.
	High_limit	The higher limit of the substance shall be specified, where available.
	Unit	The applicable unit for the amount shall be specified.
	Non_numeric_value	The non numeric value shall be specified based on a controlled vocabulary.

4.2.2. SSI for nucleic acids

For substances, which can be classified as nucleic acid the SSI the following data elements shall be specified:

SSI level	Data element name	Data element description
substance		
	Substance ID	The unique identifier assigned to the substance.
substance_name		The substance name section This section contains the set of elements for the description of the name of the substance.
	Substance_name	The name of the substance shall be specified.

SSI level	Data element name	Data element description
	Substance_name_type	The type of the name shall be specified based on a controlled vocabulary. EXAMPLE: code, brand name, established name, primary name, other name.
	Language	The language of the substance name shall be specified according to ISO 639-2 alpha-3 codes.
official_name		The official name section
	Official_name_type	The type of the official name shall be specified based on a controlled vocabulary. EXAMPLE: USAN, INN, JAN, BAN, USP, EP, INCI, JECFA
	Official_name_status	The status of the official name shall be specified based on a controlled vocabulary. EXAMPLE: current, alternate, superceded, proposed
	Official_name_status_change_date	The change date of the status of the official name shall be specified in line with the ISO 8601 date format, which shall be only entered when name is changed.
official_name_domain		The official domain name section
	Official_name_domain	The domain of the name shall be provided based on a controlled vocabulary. EXAMPLE: biologic
official_name_jurisdiction		The jurisdiction of the official name section
	Official_name_jurisdiction	The jurisdiction of the official name shall be provided based on ISO 3166-1 alpha-2 codes with two exceptions: EL (not GR) is used to represent Greece, and UK (not GB) is used to represent the United Kingdom.
reference_source		The reference source section This section describes the reference source information.
	Public_domain	It shall be specified if the reference source information is public or not. Yes or No values apply.

SSI level	Data element name	Data element description
	Reference_source_type	The type of the reference source shall be specified based on a controlled vocabulary. EXAMPLE: INN
	Reference_source_id	The reference source identifier shall be specified.
	Reference_source_citation	The literature or regulatory document reference shall be described.
	Reference_source_class	The class of the reference source shall be specified based on a controlled vocabulary. EXAMPLE: public, regulatory submission
substance_code		The substance code section This section describes the code system(s) that apply to a substance.
	Code	The specific code with regard to a referenced code system shall be provided.
	Code_system	The code system shall be specified based on a controlled vocabulary EXAMPLE: CAS, EINECS, NSC, ASK, ATC, Ndf-Rt; Rx-Cui
	Code_system_id	The identifier for the code system shall be provided based on a controlled vocabulary.
	Code_system_status	The status of the code system shall be specified based on a controlled vocabulary. EXAMPLE: current, alternate, superceded.
	Code_system_change_date	The change date of the code system shall be specified in line with the ISO 8601 date format, where applicable. This shall be generated when the status changes.
	Comment	Any comment shall be provided in this field, if required.

SSI level	Data element name	Data element description
reference_source		The reference source section This section described the reference sources of the information.
	Public_domain	It shall be specified if the reference source information is public or not. Yes or No values apply.
	Reference_source_type	The type of the reference source shall be specified based on a controlled vocabulary.
	Reference_source_class	The class of the reference source shall be specified based on a controlled vocabulary. EXAMPLE: public, regulatory submission
	Reference_source_id	The reference source identifier shall be specified.
	Reference_source_citation	The literature or regulatory document reference shall be referenced.
version		The version section This section shall provide information on the version of the substance information.
	Version_number	The number of the version of the SSI shall be provided.
	Effective_date	The date when the SSI was effective shall be provided in line with the ISO 8601 date format. This shall be defined when the SSI is generated or modified.
	Change_made	The description of the updates or changes of the SSI shall be specified.
reference_informati on		The reference information section This section is used to provide details about the reference information.
	Comment	Additional information as regards the applicable references can be specified.
substance_classifica tion		The substance classification

SSI level	Data element name	Data element description
	Domain	The domain of the substance classification shall be provided based on a controlled vocabulary. EXAMPLE: vaccine, colorant, flavor
	Substance_classification	The substance classification shall be provided based on a controlled vocabulary. EXAMPLE: hmg-coeductase inhibitor
	Substance_classification_type	The type of the classification applied shall be provided based on a controlled vocabulary. EXAMPLE: WHO-ATC, NDF-RT
	Substance_classification_code	The code of the classification type shall be specified based on a controlled vocabulary. EXAMPLE: ATC code, NDF-RT code
Subtype		The subtype section
	Substance_class_subtype	The sub-type of the classification shall be described based on a controlled vocabulary. EXAMPLE: human, viral, bacteria, fungal
reference_source		The reference source section This section described the reference sources of the information.
	Public_domain	It shall be specified if the reference source information is public or not. Yes or No values apply.
	Reference_source_type	The type of the reference source shall be specified based on a controlled vocabulary.
	Reference_source_class	The class of the reference source shall be specified based on a controlled vocabulary. EXAMPLE: public, regulatory submission
	Reference_source_id	The reference source identifier shall be specified.
	Reference_source_citation	The literature or regulatory document reference shall be referenced.

SSI level	Data element name	Data element description
substance_relationship		<p>The substance relationship</p> <p>This section shall provide information related to relationship of a substance, where this is applicable.</p>
	Relationship	<p>The relationship of a substance shall be defined based on a controlled vocabulary.</p> <p>EXAMPLE: active moiety, constituent, impurity, degradant, may contain, metabolite, target, transporter, metabolic enzyme, gene element, etc</p>
	Interaction_type	<p>The type of interaction shall be specified based on a controlled vocabulary, where applicable.</p> <p>EXAMPLE: substrate, agonist, partial agonist, antagonist</p>
	Substance_id	The substance identifier, for which the relationship is specified, shall be described.
	Substance_name	The substance name shall be specified.
	Amount_type	<p>The type of the amount of the substance shall be specified using a controlled vocabulary.</p> <p>EXAMPLE: mole ratio, weight percent</p>
amount		The amount section
	Average	The average amount or single value of the substance shall be specified.
	Low_limit	The lower limit of the substance shall be specified, where available.
	High_limit	The higher limit of the substance shall be specified, where available.
	Unit	The applicable unit for the amount shall be specified.
	Non_numeric_value	The non numeric value shall be specified based on a controlled vocabulary.
reference_source		<p>The reference source section</p> <p>This section described the reference sources of the information.</p>

SSI level	Data element name	Data element description
	Public_domain	It shall be specified if the reference source information is public or not. Yes or No values apply.
	Reference_source_type	The type of the reference source shall be specified based on a controlled vocabulary.
	Reference_source_class	The class of the reference source shall be specified based on a controlled vocabulary. EXAMPLE: public, regulatory submission
	Reference_source_id	The reference source identifier shall be specified.
	Reference_source_citation	The literature or regulatory document reference shall be referenced.
Gene		The gene section This section shall provide a description of the gene in relation to a substance, where applicable.
	Gene_sequence_origin	The common name for the organism from which the final gene sequence originated shall be specified; this applies primarily to proteins.
	Gene_id	The identifier of the gene shall be provided.
	Gene_name	The complete name given for a gene shall be provided.
reference_source		The reference source section This section described the reference sources of the information.
	Public_domain	It shall be specified if the reference source information is public or not. Yes or No values apply.
	Reference_source_type	The type of the reference source shall be specified based on a controlled vocabulary.

SSI level	Data element name	Data element description
	Reference_source_class	The class of the reference source shall be specified based on a controlled vocabulary. EXAMPLE: public, regulatory submission
	Reference_source_id	The reference source identifier shall be specified.
	Reference_source_citation	The literature or regulatory document reference shall be referenced.
gene_element		The gene element section
	Gene_element_type	The type of the gene element shall be specified based on a controlled vocabulary. EXAMPLE: enhancer, promoter, silencer, terminator, repressor (..)
	Gene_element_id	The unique identifier for the gene element shall be specified based on a controlled vocabulary.
	Gene_element_name	The specific gene element name shall be described based on a controlled vocabulary.
reference_source		The reference source section This section described the reference sources of the information.
	Public_domain	It shall be specified if the reference source information is public or not. Yes or No values apply.
	Reference_source_type	The type of the reference source shall be specified based on a controlled vocabulary.
	Reference_source_class	The class of the reference source shall be specified based on a controlled vocabulary. EXAMPLE: public, regulatory submission
	Reference_source_id	The reference source identifier shall be specified.
	Reference_source_citation	The literature or regulatory document reference shall be referenced.

SSI level	Data element name	Data element description
target		The target section This section shall provide information on the target substance.
	Target_gene_id	The identifier of the target gene shall be provided.
	Target_gene_name	The target gene name shall be specified based on a controlled vocabulary. EXAMPLE: single substance, a pathway, an enzyme type
	Interaction_type	The type of interaction shall be specified based on a controlled vocabulary. EXAMPLE: inhibitor, inducer
	Target_organism_type	The type of target organism shall be specified based on a controlled vocabulary. EXAMPLE: human, viral, bacteria, fungal
	Target_type	The target type shall be specified based on a controlled vocabulary. EXAMPLE: enzyme, receptor, membrane
	reference_source	
Public_domain		It shall be specified if the reference source information is public or not. Yes or No values apply.
Reference_source_type		The type of the reference source shall be specified based on a controlled vocabulary.
Reference_source_class		The class of the reference source shall be specified based on a controlled vocabulary. EXAMPLE: public, regulatory submission
Reference_source_id		The reference source identifier shall be specified.
Reference_source_citation		The literature or regulatory document reference shall be referenced.

SSI level	Data element name	Data element description
structure		The structure section The structure of the substance shall be described, where applicable
	Structural_representation_type	The type of the structural representation shall be described based on a controlled vocabulary. EXAMPLE: inchi, mol file
	Structural_representation	The structural representation shall be provided.
	Structural_representation_attachment	A copy of the structural representation shall be provided.
	Stereochemistry	The stereochemistry of the substance shall be described based on a controlled vocabulary. EXAMPLE: racemic; meso; mixed; unknown; axial, absolute; achiral (cis/trans or geometric isomerism indicated in structure)
	Optical_activity	The optical activity shall be described based on a controlled vocabulary. EXAMPLE: (+), (-), (+/-)
	Molecular_formula	The molecular formula shall be provided.
isotope		The isotope section The isotope shall be described in this section, where applicable.
	Nuclide_id	The identifier for each nuclide shall be provided based on a controlled vocabulary.
	Nuclide_name	The name for the nuclide shall be provided.
	Substitution_type	The type of substitution shall be described using a controlled vocabulary. EXAMPLE: specific; non-specific; unknown
nucleic_acid		This section provides a description of the identifying characteristics of a nucleic acid.

SSI level	Data element name	Data element description
	Sequence_type	The type of the sequence shall be specified based on a controlled vocabulary. EXAMPLE: complete, partial protein descriptive elements will only be used when a complete or partial amino acid sequence is available or derivable from a nucleic acid sequence.
	Number_of_subunits	The number of linear sequences of amino acids linked through peptide bonds shall be described.
	Area_of_hybridisation	The area of hybridization shall be specified.
	Comment	Any further information may be provided.
nucleic_acid_subunit		The nucleic acid subunit This section describes the nucleic acid subunits.
	Subunit	The numeric value that relates back to subunit shall be specified in order of decreasing length. Sequences of the same length will be ordered by molecular weight. Subunits that have identical sequences will be repeated and have sequential subscripts. EXAMPLE: 1,2,3,..
	Sequence	The nucleotide sequence shall be specified.
	Length	The number of nucleotide residues linked through phosphate esters shall be specified.
	Five_prime	The five prima shall be specified.
	Three_prime	The three prima shall be described.
modification		The modification section The modification details shall be specified.

SSI level	Data element name	Data element description
	Modification_type	The type of the modification shall be provided based on a controlled vocabulary. EXAMPLE: enzymatic
	Residue_modified	The residue modified shall be described based on controlled vocabulary. EXAMPLES: 20 amino acids plus 5 nucleotides
	Residue_site	The position of specific modifications shall be described. EXAMPLE: 1_10 refers to the 10th residue on the 1st subunit
physical_modification		The physical modification section
	Role	The role of the physical modification shall be provided based on a controlled vocabulary. EXAMPLE: inactivation, activation
	Number_of_parameters	The number of parameter describing the physical modification shall be provided.
parameter		The parameter section
	Parameter	The parameter shall be described based on controlled vocabulary. EXAMPLE: time, temperature
	Amount_type	The type of the amount based on a controlled vocabulary shall be specified. EXAMPLE: mole ratio, weight percent
amount		The amount section
	Average	The average amount or single value of the substance shall be specified.
	Low_limit	The lower limit of the substance shall be specified, where available.
	High_limit	The higher limit of the substance shall be specified, where available.
	Unit	The applicable unit for the amount shall be specified.

SSI level	Data element name	Data element description
	Non_numeric_value	The non numeric value shall be specified based on a controlled vocabulary.
structural_modification		The structural modification section
	Structural_modification_type	The type of the structural modification shall be described based on a controlled vocabulary example: moiety, molecular fragment
moiety		The moiety section
	Moiety_role	The role of the moiety shall be described based on a controlled vocabulary. EXAMPLE: antigen, linker, conjugate
	Moiety_name	The name of the moiety shall be provided.
	Moiety_id	The unique identifier of the moiety shall be provided.
	Amount_type	The type of the amount based on a controlled vocabulary. EXAMPLE: mole ratio, weight percent
amount		The amount section
	Average	The average amount or single value of the substance shall be specified.
	Low_limit	The lower limit of the substance shall be specified, where available.
	High_limit	The higher limit of the substance shall be specified, where available.
	Unit	The applicable unit for the amount shall be specified.
	Non_numeric_value	The non numeric value shall be specified based on a controlled vocabulary.
molecular_fragment		The molecular fragment section
	Role	The role of the molecular fragment shall be described based on a controlled vocabulary. EXAMPLE: antigen, linker, conjugate

SSI level	Data element name	Data element description
	Molecular_fragment_id	The unique identifier for molecular fragment shall be provided.
	Molecular_fragment_name	The name for molecular fragment shall be specified.
	Amount_type	The type of the amount based on a controlled vocabulary. EXAMPLE: mole ratio, weight percent
amount		The amount section
	Average	The average amount or single value of the substance shall be specified.
	Low_limit	The lower limit of the substance shall be specified, where available.
	High_limit	The higher limit of the substance shall be specified, where available.
	Unit	The applicable unit for the amount shall be specified.
	Non_numeric_value	The non numeric value shall be specified based on a controlled vocabulary.
agent_modification		The modification agent section
	Agent_modification_type	The type of the agent used for the modification shall be specified based on a controlled vocabulary. EXAMPLE: chemical, enzymatic, immunological, organismal
	Role	The role of the modification agent shall be specified based on a controlled vocabulary. EXAMPLE: inactivation, activation, pegylation, phosphorylation
	Modification_agent	The name of modifying agent shall be specified.
	Modification_agent_id	The unique identifier of modifying agent shall be provided.
	Modification_process	The modification process shall be specified based on a controlled vocabulary. EXAMPLE: cell culture, UV irradiation

SSI level	Data element name	Data element description
	Amount_type	The type of the amount based on a controlled vocabulary shall be specified. EXAMPLE: mole ratio, weight percent
amount		The amount section
	Average	The average amount or single value of the substance shall be specified.
	Low_limit	The lower limit of the substance shall be specified, where available.
	High_limit	The higher limit of the substance shall be specified, where available.
	Unit	The applicable unit for the amount shall be specified.
	Non_numeric_value	The non numeric value shall be specified based on a controlled vocabulary.
property		The property section The characteristics of the property shall be described.
	Property_type	The type of property shall be specified based on a controlled vocabulary. EXAMPLE: physical, chemical, enzymatic, immunological
	Property_name	The name of property shall be specified.
	Substance_id	The identifier of the substance related to a defining property shall be described. EXAMPLE: for cell surface antigens, the substance id for cd4 would be captured to define cd4 positive cells
	Substance_name	The name of the substance related to a defining property shall be described. EXAMPLE: for cell surface antigens
	Amount_type	The type of the amount based on a controlled vocabulary shall be specified. EXAMPLE: mole ratio, weight percent

SSI level	Data element name	Data element description
amount		The amount section
	Average	The average amount or single value of the substance shall be specified.
	Low_limit	The lower limit of the substance shall be specified, where available.
	High_limit	The higher limit of the substance shall be specified, where available.
	Unit	The applicable unit for the amount shall be specified.
	Non_numeric_value	The non numeric value shall be specified based on a controlled vocabulary.
molecular_weight		The molecular weight section
	Molecular_weight_method	The method used to measure the molecular weight shall be specified based on a controlled vocabulary. EXAMPLE: sds_page, calculated, light scattering viscosity, gel permeation
	Molecular_weight_type	The type of the molecular weight shall be specified based on a controlled vocabulary. EXAMPLE: exact, average (aka. number average), weight average
	Amount_type	The type of the amount based on a controlled vocabulary. EXAMPLE: mole ratio, weight percent
amount		The amount section
	Average	The average amount or single value of the substance shall be specified.
	Low_limit	The lower limit of the substance shall be specified, where available.
	High_limit	The higher limit of the substance shall be specified, where available.
	Unit	The applicable unit for the amount shall be specified.
	Non_numeric_value	The non numeric value shall be specified based on a controlled vocabulary.

SSI level	Data element name	Data element description
reference_source		The reference source section This section described the reference sources of the information.
	Public_domain	It shall be specified if the reference source information is public or not. Yes or No values apply.
	Reference_source_type	The type of the reference source shall be specified based on a controlled vocabulary.
	Reference_source_class	The class of the reference source shall be specified based on a controlled vocabulary. EXAMPLE: public, regulatory submission
	Reference_source_id	The reference source identifier shall be specified.
	Reference_source_citation	The literature or regulatory document reference shall be referenced.

4.2.3. SSI for polymers

For substances that can be classified as polymers, the following data elements shall be specified:

SSI level	Data element name	Data element description
substance		
	Substance ID	The unique identifier assigned to the substance.
substance_name		The substance name section This section contains the set of elements for the description of the name of the substance.
	Substance_name	The name of the substance shall be specified.
	Substance_name_type	The type of the name shall be specified based on a controlled vocabulary. EXAMPLE: code, brand name, established name, primary name, other name.

SSI level	Data element name	Data element description
	Language	The language of the substance name shall be specified according to ISO 639-2 alpha-3 codes.
official_name		The official name section
	Official_name_type	The type of the official name shall be specified based on a controlled vocabulary. EXAMPLE: USAN, INN, JAN, BAN, USP, EP, INCI, JECFA
	Official_name_status	The status of the official name shall be specified based on a controlled vocabulary. EXAMPLE: current, alternate, superceded, proposed
	Official_name_status_change_date	The change date of the status of the official name shall be specified in line with the ISO 8601 date format, which shall be only entered when name is changed.
official_name_domain		The official domain name section
	Official_name_domain	The domain of the name shall be provided based on a controlled vocabulary. EXAMPLE: biologic
official_name_jurisdiction		The jurisdiction of the official name section
	Official_name_jurisdiction	The jurisdiction of the official name shall be provided based on ISO 3166-1 alpha-2 codes with two exceptions: EL (not GR) is used to represent Greece, and UK (not GB) is used to represent the United Kingdom.
reference_source		The reference source section This section describes the reference source information.
	Public_domain	It shall be specified if the reference source information is public or not. Yes or No values apply.
	Reference_source_type	The type of the reference source shall be specified based on a controlled vocabulary. EXAMPLE: INN

SSI level	Data element name	Data element description
	Reference_source_class	The class of the reference source shall be specified based on a controlled vocabulary. EXAMPLE: public, regulatory submission
	Reference_source_id	The reference source identifier shall be specified.
	Reference_source_citation	The literature or regulatory document reference shall be described.
substance_code		The substance code section This section describes the code system(s) that apply to a substance.
	Code	The specific code with regard to a referenced code system shall be provided.
	Code_system	The code system shall be specified based on a controlled vocabulary EXAMPLE: CAS, EINECS, NSC, ASK, ATC, Ndf-Rt; Rx-Cui
	Code_system_id	The identifier for the code system shall be provided based on a controlled vocabulary.
	Code_system_status	The status of the code system shall be specified based on a controlled vocabulary. EXAMPLE: current, alternate, superceded.
	Code_system_change_date	The change date of the code system shall be specified in line with the ISO 8601 date format, where applicable. This shall be generated when the status changes.
	Comment	Any comment shall be provided in this field, if required.
reference_source		The reference source section This section described the reference sources of the information.

SSI level	Data element name	Data element description
	Public_domain	It shall be specified if the reference source information is public or not. Yes or No values apply.
	Reference_source_type	The type of the reference source shall be specified based on a controlled vocabulary.
	Reference_source_class	The class of the reference source shall be specified based on a controlled vocabulary. EXAMPLE: public, regulatory submission
	Reference_source_id	The reference source identifier shall be specified.
	Reference_source_citation	The literature or regulatory document reference shall be referenced.
version		The version section This section shall provide information on the version of the substance information.
	Version_number	The number of the version of the SSI shall be provided.
	Effective_date	The date when the SSI was effective shall be provided in line with the ISO 8601 date format. This shall be defined when the SSI is generated or modified.
	Change_made	The description of the updates or changes of the SSI shall be specified.
reference_informati on		The reference information section This section is used to provide details about the reference information.
	Comment	Additional information as regards the applicable references can be specified.
substance_classifica tion		The substance classification

SSI level	Data element name	Data element description
	Domain	The domain of the substance classification shall be provided based on a controlled vocabulary. EXAMPLE: vaccine, colorant, flavor
	Substance_classification	The substance classification shall be provided based on a controlled vocabulary. EXAMPLE: hmg-coeductase inhibitor
	Substance_classification_type	The type of the classification applied shall be provided based on a controlled vocabulary. EXAMPLE: WHO-ATC, NDF-RT
	Substance_classification_code	The code of the classification type shall be specified based on a controlled vocabulary. EXAMPLE: ATC code, NDF-RT code
subtype		The subtype section
	Substance_class_subtype	The sub-type of the classification shall be described based on a controlled vocabulary. EXAMPLE: human, viral, bacteria, fungal
reference_source		The reference source section This section described the reference sources of the information.
	Public_domain	It shall be specified if the reference source information is public or not. Yes or No values apply.
	Reference_source_type	The type of the reference source shall be specified based on a controlled vocabulary.
	Reference_source_class	The class of the reference source shall be specified based on a controlled vocabulary. EXAMPLE: public, regulatory submission
	Reference_source_id	The reference source identifier shall be specified.
	Reference_source_citation	The literature or regulatory document reference shall be referenced.

SSI level	Data element name	Data element description
substance_relationship		<p>The substance relationship</p> <p>This section shall provide information related to relationship of a substance, where this is applicable.</p>
	Relationship	<p>The relationship of a substance shall be defined based on a controlled vocabulary.</p> <p>EXAMPLE: active moiety, constituent, impurity, degradant, may contain, metabolite, target, transporter, metabolic enzyme, gene element, etc</p>
	Interaction_type	<p>The type of interaction shall be specified based on a controlled vocabulary, where applicable.</p> <p>EXAMPLE: substrate, agonist, partial agonist, antagonist</p>
	Substance_id	The substance identifier, for which the relationship is specified, shall be described.
	Substance_name	The substance name shall be specified.
	Amount_type	<p>The type of the amount of the substance shall be specified using a controlled vocabulary.</p> <p>EXAMPLE: mole ratio, weight percent</p>
amount		The amount section
	Average	The average amount or single value of the substance shall be specified.
	Low_limit	The lower limit of the substance shall be specified, where available.
	High_limit	The higher limit of the substance shall be specified, where available.
	Unit	The applicable unit for the amount shall be specified.
	Non_numeric_value	The non numeric value shall be specified based on a controlled vocabulary.
reference_source		<p>The reference source section</p> <p>This section described the reference sources of the information.</p>

SSI level	Data element name	Data element description
	Public_domain	It shall be specified if the reference source information is public or not. Yes or No values apply.
	Reference_source_type	The type of the reference source shall be specified based on a controlled vocabulary.
	Reference_source_class	The class of the reference source shall be specified based on a controlled vocabulary. EXAMPLE: public, regulatory submission
	Reference_source_id	The reference source identifier shall be specified.
	Reference_source_citation	The literature or regulatory document reference shall be referenced.
Gene		The gene section This section shall provide a description of the gene in relation to a substance, where applicable.
	Gene_sequence_origin	The common name for the organism from which the final gene sequence originated shall be specified; this applies primarily to proteins.
	Gene_id	The identifier of the gene shall be provided.
	Gene_name	The complete name given for a gene shall be provided.
reference_source		The reference source section This section described the reference sources of the information.
	Public_domain	It shall be specified if the reference source information is public or not. Yes or No values apply.
	Reference_source_type	The type of the reference source shall be specified based on a controlled vocabulary.

SSI level	Data element name	Data element description
	Reference_source_class	The class of the reference source shall be specified based on a controlled vocabulary. EXAMPLE: public, regulatory submission
	Reference_source_id	The reference source identifier shall be specified.
	Reference_source_citation	The literature or regulatory document reference shall be referenced.
gene_element		The gene element section
	Gene_element_type	The type of the gene element shall be specified based on a controlled vocabulary. EXAMPLE: enhancer, promoter, silencer, terminator, repressor (..)
	Gene_element_id	The unique identifier for the gene element shall be specified based on a controlled vocabulary.
	Gene_element_name	The specific gene element name shall be described based on a controlled vocabulary.
reference_source		The reference source section This section described the reference sources of the information.
	Public_domain	It shall be specified if the reference source information is public or not. Yes or No values apply.
	Reference_source_type	The type of the reference source shall be specified based on a controlled vocabulary.
	Reference_source_class	The class of the reference source shall be specified based on a controlled vocabulary. EXAMPLE: public, regulatory submission
	Reference_source_id	The reference source identifier shall be specified.
	Reference_source_citation	The literature or regulatory document reference shall be referenced.

SSI level	Data element name	Data element description
target		The target section This section shall provide information on the target substance.
	Target_gene_id	The identifier of the target gene shall be provided.
	Target_gene_name	The target gene name shall be specified based on a controlled vocabulary. EXAMPLE: single substance, a pathway, an enzyme type
	Interaction_type	The type of interaction shall be specified based on a controlled vocabulary. EXAMPLE: inhibitor, inducer
	Target_organism_type	The type of target organism shall be specified based on a controlled vocabulary. EXAMPLE: human, viral, bacteria, fungal
	Target_type	The target type shall be specified based on a controlled vocabulary. EXAMPLE: enzyme, receptor, membrane
	reference_source	
Public_domain		It shall be specified if the reference source information is public or not. Yes or No values apply.
Reference_source_type		The type of the reference source shall be specified based on a controlled vocabulary.
Reference_source_class		The class of the reference source shall be specified based on a controlled vocabulary. EXAMPLE: public, regulatory submission
Reference_source_id		The reference source identifier shall be specified.
Reference_source_citation		The literature or regulatory document reference shall be referenced.

SSI level	Data element name	Data element description
Structure		The structure section The structure of the substance shall be described, where applicable
	Structural_representation_type	The type of the structural representation shall be described based on a controlled vocabulary. EXAMPLE: inchi, mol file
	Structural_representation	The structural representation shall be provided.
	Structural_representation_attachment	A copy of the structural representation shall be provided.
	Stereochemistry	The stereochemistry of the substance shall be described based on a controlled vocabulary. EXAMPLE: racemic; meso; mixed; unknown; axial, absolute; achiral (cis/trans or geometric isomerism indicated in structure)
	Optical_activity	The optical activity shall be described based on a controlled vocabulary. EXAMPLE: (+), (-), (+/-)
	Molecular_formula	The molecular formula shall be provided.
isotope		The isotope section The isotope shall be described in this section, where applicable.
	Nuclide_id	The identifier for each nuclide shall be provided based on a controlled vocabulary.
	Nuclide_name	The name for the nuclide shall be provided.
	Substitution_type	The type of substitution shall be described using a controlled vocabulary. EXAMPLE: specific; non-specific; unknown

SSI level	Data element name	Data element description
polymer		The polymer section The characteristics the uniquely define a polymer shall be specified in this section.
	Polymer_class	The class of polymer shall be described based on a controlled vocabulary. EXAMPLE: homopolymer, copolymer
	Polymer_geometry	The geometry of the polymer shall be described based on a controlled vocabulary. EXAMPLE: linear, branched, crosslinked, network, dendritic, star
	Copolymer_sequence_type	The type of copolymer of the polymer sequence shall be described based on a controlled vocabulary. EXAMPLE: random, alternating, block, graft.
	Comment	Additional information in relation to the description of the characteristics of the polymer can be provided.
	monomer_description	The description of the monomer section
	Number_of_monomers	The number of monomers used to synthesize the polymer shall be specified.
	Monomer_amount_type	The amount type of the monomer shall be described based on a controlled vocabulary. EXAMPLE: mole ratio, weight percent
monomer		The monomer section
	Monomer_id	The unique identifier for the monomer shall be described.
	Monomer_name	The name of the monomer shall be provided.
	Amount_type	The type of the amount based on a controlled vocabulary shall be specified. EXAMPLE: mole ratio, weight percent

SSI level	Data element name	Data element description
amount		The amount section
	Average	The average amount or single value of the substance shall be specified.
	Low_limit	The lower limit of the substance shall be specified, where available.
	High_limit	The higher limit of the substance shall be specified, where available.
	Unit	The applicable unit for the amount shall be specified.
	Non_numeric_value	The non numeric value shall be specified based on a controlled vocabulary.
structural_repeat		The structural repeat section
	Number_of_structural_repeat_units	The number of repeated units represented in the structure of the polymer shall be specified.
	Structural_repeat_unit_amount_type	The type of amount of the repeat unit shall be described based on a controlled vocabulary.
structural_repeat_unit		
	Orientation_of_polymerization	The orientation of the polymerization shall be described based on a controlled vocabulary. Example: head-tail, head-head, random
	Structural_repeat_unit	The letter that relates back to the structure of the unit shall be specified in order of decreasing molecular weight. Example: a,b,c,...
	Amount_type	The type of the amount based on a controlled vocabulary shall be specified. EXAMPLE: mole ratio, weight percent
amount		The amount section
	Average	The average amount or single value of the substance shall be specified.
	Low_limit	The lower limit of the substance shall be specified, where available.

SSI level	Data element name	Data element description
	High_limit	The higher limit of the substance shall be specified, where available.
	Unit	The applicable unit for the amount shall be specified.
	Non_numeric_value	The non numeric value shall be specified based on a controlled vocabulary.
degree_polymerization		The degree of the polymerization section
	Degree_of_polymerization	The degree of polymerization shall be described.
	Amount_type	The type of the amount based on a controlled vocabulary shall be specified. EXAMPLE: mole ratio, weight percent
amount		The amount section
	Average	The average amount or single value of the substance shall be specified.
	Low_limit	The lower limit of the substance shall be specified, where available.
	High_limit	The higher limit of the substance shall be specified, where available.
	Unit	The applicable unit for the amount shall be specified.
	Non_numeric_value	The non numeric value shall be specified based on a controlled vocabulary.
molecular_weight		The molecular weight section
	Molecular_weight_method	The method used to measure the molecular weight shall be specified based on a controlled vocabulary. Example: sds_page, calculated, light scattering viscosity, gel permeation
	Molecular_weight_type	The type of the molecular weight shall be specified based on a controlled vocabulary. Example: exact, average (aka. Number average), weight average

SSI level	Data element name	Data element description
	Amount_type	The type of the amount based on a controlled vocabulary shall be specified. EXAMPLE: mole ratio, weight percent
amount		The amount section
	Average	The average amount or single value of the substance shall be specified.
	Low_limit	The lower limit of the substance shall be specified, where available.
	High_limit	The higher limit of the substance shall be specified, where available.
	Unit	The applicable unit for the amount shall be specified.
	Non_numeric_value	The non numeric value shall be specified based on a controlled vocabulary.
property		The property section The characteristics of the property shall be described.
	Property_type	The type of property shall be specified based on a controlled vocabulary. EXAMPLE: physical, chemical, enzymatic, immunological
	Property_name	The name of property shall be specified.
	Substance_id	The identifier of the substance related to a defining property shall be described. EXAMPLE: for cell surface antigens, the substance id for cd4 would be captured to define cd4 positive cells
	Substance_name	The name of the substance related to a defining property shall be described. EXAMPLE: for cell surface antigens
	Amount_type	The type of the amount based on a controlled vocabulary shall be specified. EXAMPLE: mole ratio, weight percent

SSI level	Data element name	Data element description
amount		The amount section
	Average	The average amount or single value of the substance shall be specified.
	Low_limit	The lower limit of the substance shall be specified, where available.
	High_limit	The higher limit of the substance shall be specified, where available.
	Unit	The applicable unit for the amount shall be specified.
	Non_numeric_value	The non numeric value shall be specified based on a controlled vocabulary.
modification		The modification section The modification details shall be specified.
	Modification_type	The type of the modification shall be provided based on a controlled vocabulary. EXAMPLE: enzymatic
	Residue_modified	The residue modified shall be described based on controlled vocabulary. EXAMPLES: 20 amino acids plus 5 nucleotides
	Residue_site	The position of specific modifications shall be described. EXAMPLE: 1_10 refers to the 10th residue on the 1st subunit
physical_modification		The physical modification section
	Role	The role of the physical modification shall be provided based on a controlled vocabulary. EXAMPLE: inactivation, activation
	Number_of_parameters	The number of parameter describing the physical modification shall be provided.
parameter		The parameter section

SSI level	Data element name	Data element description
	Parameter	The parameter shall be described based on controlled vocabulary. EXAMPLE: time, temperature
	Amount_type	The type of the amount based on a controlled vocabulary shall be specified. EXAMPLE: mole ratio, weight percent
amount		The amount section
	Average	The average amount or single value of the substance shall be specified.
	Low_limit	The lower limit of the substance shall be specified, where available.
	High_limit	The higher limit of the substance shall be specified, where available.
	Unit	The applicable unit for the amount shall be specified.
	Non_numeric_value	The non numeric value shall be specified based on a controlled vocabulary.
structural_modification		The structural modification section
	Structural_modification_type	The type of the structural modification shall be described based on a controlled vocabulary example: moiety, molecular fragment
moiety		The moiety section
	Moiety_role	The role of the moiety shall be described based on a controlled vocabulary. EXAMPLE: antigen, linker, conjugate
	Moiety_id	The unique identifier of the moiety shall be provided.
	Moiety_name	The name of the moiety shall be provided.
	Amount_type	The type of the amount based on a controlled vocabulary. EXAMPLE: mole ratio, weight percent
amount		The amount section

SSI level	Data element name	Data element description
	Average	The average amount or single value of the substance shall be specified.
	Low_limit	The lower limit of the substance shall be specified, where available.
	High_limit	The higher limit of the substance shall be specified, where available.
	Unit	The applicable unit for the amount shall be specified.
	Non_numeric_value	The non numeric value shall be specified based on a controlled vocabulary.
molecular_fragment		The molecular fragment section
	Role	The role of the molecular fragment shall be described based on a controlled vocabulary. EXAMPLE: antigen, linker, conjugate
	Molecular_fragment_id	The unique identifier for molecular fragment shall be provided.
	Molecular_fragment_name	The name for molecular fragment shall be specified.
	Amount_type	The type of the amount based on a controlled vocabulary. EXAMPLE: mole ratio, weight percent
amount		The amount section
	Average	The average amount or single value of the substance shall be specified.
	Low_limit	The lower limit of the substance shall be specified, where available.
	High_limit	The higher limit of the substance shall be specified, where available.
	Unit	The applicable unit for the amount shall be specified.
	Non_numeric_value	The non numeric value shall be specified based on a controlled vocabulary.
agent_modification		The modification agent section

SSI level	Data element name	Data element description
	Agent_modification_type	The type of the agent used for the modification shall be specified based on a controlled vocabulary. EXAMPLE: chemical, enzymatic, immunological, organismal
	Role	The role of the modification agent shall be specified based on a controlled vocabulary. EXAMPLE: inactivation, activation, pegylation, phosphorylation
	Modification_agent	The name of modifying agent shall be specified.
	Modification_agent_id	The unique identifier of modifying agent shall be provided.
	Modification_process	The modification process shall be specified based on a controlled vocabulary. EXAMPLE: cell culture, UV irradiation
	Amount_type	The type of the amount based on a controlled vocabulary shall be specified. EXAMPLE: mole ratio, weight percent
amount		The amount section
	Average	The average amount or single value of the substance shall be specified.
	Low_limit	The lower limit of the substance shall be specified, where available.
	High_limit	The higher limit of the substance shall be specified, where available.
	Unit	The applicable unit for the amount shall be specified.
	Non_numeric_value	The non numeric value shall be specified based on a controlled vocabulary.
source_material		The source material section The source material shall be specified in this section.

SSI level	Data element name	Data element description
	Source_material_class	The classification of the source material shall be specified based on controlled vocabulary. EXAMPLE: organism, mineral
	Source_material_type	The type of the source material shall be specified based on controlled vocabulary. For vaccines this is the class of infectious agent. EXAMPLE: bacterium, human, mammal, fungus, virus, plant, virus
	Source_material_state	The state of the source material shall be specified based on controlled vocabulary. EXAMPLE: live, activated, inactivated, attenuated, conjugated, live (attenuated).
	Organism_name_id	The unique identifier associated with the source material parent organism shall be specified.
	Organism_name	The organism accepted Latin name shall be provided.
	Developmental_stage	The developmental stage shall be defined based on a controlled vocabulary. EXAMPLE: foetus, infant, juvenile, adult, senescent, leafing, pre-flowering, flowering, fruiting
part		The part section
	Part	The portion of an organism with a definable anatomical location shall be described based on a controlled vocabulary.
	Part_location	The anatomical location shall be specified based on a controlled vocabulary.
fraction		The fraction section

SSI level	Data element name	Data element description
	Material_type	The material type shall be specified based on a controlled vocabulary. EXAMPLE: cell, protein, polysaccharide, nucleic acid, expressed oil, essential oil
	Fraction	The fraction shall be specified based on a controlled vocabulary.
organism		The organism section The organism shall be defined based on specific elements defined in this section.
	Kingdom	The kingdom of an organism shall be specified based on a controlled vocabulary.
	Phylum	The phylum of an organism shall be specified based on a controlled vocabulary.
	Class	The class of an organism shall be specified based on a controlled vocabulary.
	Order	The order of an organism shall be specified based on a controlled vocabulary.
	Family	The family of an organism shall be specified based on a controlled vocabulary.
	Genus	The genus of an organism shall be specified based on a controlled vocabulary.
	Species	The species of an organism shall be specified based on a controlled vocabulary.
	Species_parenthetical_author	The parenthetical author of an organism species shall be specified based on a controlled vocabulary.
	Species_parenthetical_author_year	The parenthetical author year of an organism species an organism shall be specified based on a controlled vocabulary.

SSI level	Data element name	Data element description
	Species_primary_author	The primary author of an organism species shall be specified based on a controlled vocabulary.
	Species_primary_author_year	The primary author year of an organism species shall be specified based on a controlled vocabulary.
	Hybrid_species_maternal_organism_id	The identifier of the maternal species constituting the hybrid organism shall be specified based on a controlled vocabulary.
	Hybrid_species_paternal_organism_id	The identifier of the paternal species constituting the hybrid organism shall be specified based on a controlled vocabulary.
	Hybrid_type	The hybrid type of an organism shall be defined. EXAMPLE: yes/no
	Infraspecific_type	The infraspecific type of an organism shall be specified based on a controlled vocabulary.
	Infraspecific_description	The infraspecific type of an organism shall be specified based on a controlled vocabulary.
	Infraspecific_parenthetical_author	The infraspecific parenthetical author of an organism shall be specified based on a controlled vocabulary.
	Infraspecific_parenthetical_author_year	The infraspecific parenthetical author year of an organism shall be specified based on a controlled vocabulary.
	Infraspecific_primary_author	The infraspecific primary author of an organism shall be specified based on a controlled vocabulary.
	Infraspecific_primary_author_year	The infraspecific primary author year of an organism shall be specified based on a controlled vocabulary.
reference_source		The reference source section This section described the reference sources of the information.
	Public_domain	It shall be specified if the reference source information is public or not. Yes or No values apply.

SSI level	Data element name	Data element description
	Reference_source_type	The type of the reference source shall be specified based on a controlled vocabulary.
	Reference_source_class	The class of the reference source shall be specified based on a controlled vocabulary. EXAMPLE: public, regulatory submission
	Reference_source_id	The reference source identifier shall be specified.
	Reference_source_citation	The literature or regulatory document reference shall be referenced.

4.2.4. SSI for proteins

For substances that can be classified as proteins, the following data elements shall be specified:

SSI level	Data element name	Data element description
substance		
	Substance ID	The unique identifier assigned to the substance.
substance_name		The substance name section This section contains the set of elements for the description of the name of the substance.
	Substance_name	The name of the substance shall be specified.
	Substance_name_type	The type of the name shall be specified based on a controlled vocabulary. EXAMPLE: code, brand name, established name, primary name, other name.
	Language	The language of the substance name shall be specified according to ISO 639-2 alpha-3 codes.
official_name		The official name section

SSI level	Data element name	Data element description
	Official_name_type	The type of the official name shall be specified based on a controlled vocabulary. EXAMPLE: USAN, INN, JAN, BAN, USP, EP, INCI, JECFA
	Official_name_status	The status of the official name shall be specified based on a controlled vocabulary. EXAMPLE: current, alternate, superceded, proposed
	Official_name_status_change_date	The change date of the status of the official name shall be specified in line with the ISO 8601 date format, which shall be only entered when name is changed.
official_name_domain		The official domain name section
	Official_name_domain	The domain of the name shall be provided based on a controlled vocabulary. EXAMPLE: biologic
official_name_jurisdiction		The jurisdiction of the official name section
	Official_name_jurisdiction	The jurisdiction of the official name shall be provided based on ISO 3166-1 alpha-2 codes with two exceptions: EL (not GR) is used to represent Greece, and UK (not GB) is used to represent the United Kingdom.
reference_source		The reference source section This section describes the reference source information.
	Public_domain	It shall be specified if the reference source information is public or not. Yes or No values apply.
	Reference_source_type	The type of the reference source shall be specified based on a controlled vocabulary. EXAMPLE: INN

SSI level	Data element name	Data element description
	Reference_source_class	The class of the reference source shall be specified based on a controlled vocabulary. EXAMPLE: public, regulatory submission
	Reference_source_id	The reference source identifier shall be specified.
	Reference_source_citation	The literature or regulatory document reference shall be described.
substance_code		The substance code section This section describes the code system(s) that apply to a substance.
	Code	The specific code with regard to a referenced code system shall be provided.
	Code_system	The code system shall be specified based on a controlled vocabulary EXAMPLE: CAS, EINECS, NSC, ASK, ATC, Ndf-Rt; Rx-Cui
	Code_system_id	The identifier for the code system shall be provided based on a controlled vocabulary.
	Code_system_status	The status of the code system shall be specified based on a controlled vocabulary. EXAMPLE: current, alternate, superceded.
	Code_system_change_date	The change date of the code system shall be specified in line with the ISO 8601 date format, where applicable. This shall be generated when the status changes.
	Comment	Any comment shall be provided in this field, if required.
reference_source		The reference source section This section described the reference sources of the information.

SSI level	Data element name	Data element description
	Public_domain	It shall be specified if the reference source information is public or not. Yes or No values apply.
	Reference_source_type	The type of the reference source shall be specified based on a controlled vocabulary.
	Reference_source_class	The class of the reference source shall be specified based on a controlled vocabulary. EXAMPLE: public, regulatory submission
	Reference_source_id	The reference source identifier shall be specified.
	Reference_source_citation	The literature or regulatory document reference shall be referenced.
version		The version section This section shall provide information on the version of the substance information.
	Version_number	The number of the version of the SSI shall be provided.
	Effective_date	The date when the SSI was effective shall be provided in line with the ISO 8601 date format. This shall be defined when the SSI is generated or modified.
	Change_made	The description of the updates or changes of the SSI shall be specified.
reference_informati on		The reference information section This section is used to provide details about the reference information.
	Comment	Additional information as regards the applicable references can be specified.
substance_classifica tion		The substance classification

SSI level	Data element name	Data element description
	Domain	The domain of the substance classification shall be provided based on a controlled vocabulary. EXAMPLE: vaccine, colorant, flavor
	Substance_classification	The substance classification shall be provided based on a controlled vocabulary. EXAMPLE: hmg-coeductase inhibitor
	Substance_classification_type	The type of the classification applied shall be provided based on a controlled vocabulary. EXAMPLE: WHO-ATC, NDF-RT
	Substance_classification_code	The code of the classification type shall be specified based on a controlled vocabulary. EXAMPLE: ATC code, NDF-RT code
subtype		The subtype section
	Substance_class_subtype	The sub-type of the classification shall be described based on a controlled vocabulary. EXAMPLE: human, viral, bacteria, fungal
reference_source		The reference source section This section described the reference sources of the information.
	Public_domain	It shall be specified if the reference source information is public or not. Yes or No values apply.
	Reference_source_type	The type of the reference source shall be specified based on a controlled vocabulary.
	Reference_source_class	The class of the reference source shall be specified based on a controlled vocabulary. EXAMPLE: public, regulatory submission
	Reference_source_id	The reference source identifier shall be specified.
	Reference_source_citation	The literature or regulatory document reference shall be referenced.

SSI level	Data element name	Data element description
substance_relationship		<p>The substance relationship</p> <p>This section shall provide information related to relationship of a substance, where this is applicable.</p>
	Relationship	<p>The relationship of a substance shall be defined based on a controlled vocabulary.</p> <p>EXAMPLE: active moiety, constituent, impurity, degradant, may contain, metabolite, target, transporter, metabolic enzyme, gene element, etc</p>
	Interaction_type	<p>The type of interaction shall be specified based on a controlled vocabulary, where applicable.</p> <p>EXAMPLE: substrate, agonist, partial agonist, antagonist</p>
	Substance_id	The substance identifier, for which the relationship is specified, shall be described.
	Substance_name	The substance name shall be specified.
	Amount_type	<p>The type of the amount of the substance shall be specified using a controlled vocabulary.</p> <p>EXAMPLE: mole ratio, weight percent</p>
amount		The amount section
	Average	The average amount or single value of the substance shall be specified.
	Low_limit	The lower limit of the substance shall be specified, where available.
	High_limit	The higher limit of the substance shall be specified, where available.
	Unit	The applicable unit for the amount shall be specified.
	Non_numeric_value	The non numeric value shall be specified based on a controlled vocabulary.
reference_source		<p>The reference source section</p> <p>This section described the reference sources of the information.</p>

SSI level	Data element name	Data element description
	Public_domain	It shall be specified if the reference source information is public or not. Yes or No values apply.
	Reference_source_type	The type of the reference source shall be specified based on a controlled vocabulary.
	Reference_source_class	The class of the reference source shall be specified based on a controlled vocabulary. EXAMPLE: public, regulatory submission
	Reference_source_id	The reference source identifier shall be specified.
	Reference_source_citation	The literature or regulatory document reference shall be referenced.
Gene		The gene section This section shall provide a description of the gene in relation to a substance, where applicable.
	Gene_sequence_origin	The common name for the organism from which the final gene sequence originated shall be specified; this applies primarily to proteins.
	Gene_id	The identifier of the gene shall be provided.
	Gene_name	The complete name given for a gene shall be provided.
reference_source		The reference source section This section described the reference sources of the information.
	Public_domain	It shall be specified if the reference source information is public or not. Yes or No values apply.
	Reference_source_type	The type of the reference source shall be specified based on a controlled vocabulary.

SSI level	Data element name	Data element description
	Reference_source_class	The class of the reference source shall be specified based on a controlled vocabulary. EXAMPLE: public, regulatory submission
	Reference_source_id	The reference source identifier shall be specified.
	Reference_source_citation	The literature or regulatory document reference shall be referenced.
gene_element		The gene element section
	Gene_element_type	The type of the gene element shall be specified based on a controlled vocabulary. EXAMPLE: enhancer, promoter, silencer, terminator, repressor (..)
	Gene_element_id	The unique identifier for the gene element shall be specified based on a controlled vocabulary.
	Gene_element_name	The specific gene element name shall be described based on a controlled vocabulary.
reference_source		The reference source section This section described the reference sources of the information.
	Public_domain	It shall be specified if the reference source information is public or not. Yes or No values apply.
	Reference_source_type	The type of the reference source shall be specified based on a controlled vocabulary.
	Reference_source_class	The class of the reference source shall be specified based on a controlled vocabulary. EXAMPLE: public, regulatory submission
	Reference_source_id	The reference source identifier shall be specified.
	Reference_source_citation	The literature or regulatory document reference shall be referenced.

SSI level	Data element name	Data element description
target		The target section This section shall provide information on the target substance.
	Target_gene_id	The identifier of the target gene shall be provided.
	Target_gene_name	The target gene name shall be specified based on a controlled vocabulary. EXAMPLE: single substance, a pathway, an enzyme type
	Interaction_type	The type of interaction shall be specified based on a controlled vocabulary. EXAMPLE: inhibitor, inducer
	Target_organism_type	The type of target organism shall be specified based on a controlled vocabulary. EXAMPLE: human, viral, bacteria, fungal
	Target_type	The target type shall be specified based on a controlled vocabulary. EXAMPLE: enzyme, receptor, membrane
reference_source		The reference source section This section described the reference sources of the information.
	Public_domain	It shall be specified if the reference source information is public or not. Yes or No values apply.
	Reference_source_type	The type of the reference source shall be specified based on a controlled vocabulary.
	Reference_source_class	The class of the reference source shall be specified based on a controlled vocabulary. EXAMPLE: public, regulatory submission
	Reference_source_id	The reference source identifier shall be specified.
	Reference_source_citation	The literature or regulatory document reference shall be referenced.

SSI level	Data element name	Data element description
structure		The structure section The structure of the substance shall be described, where applicable
	Structural_representation_type	The type of the structural representation shall be described based on a controlled vocabulary. EXAMPLE: inchi, mol file
	Structural_representation	The structural representation shall be provided.
	Structural_representation_attachment	A copy of the structural representation shall be provided.
	Stereochemistry	The stereochemistry of the substance shall be described based on a controlled vocabulary. EXAMPLE: racemic; meso; mixed; unknown; axial, absolute; achiral (cis/trans or geometric isomerism indicated in structure)
	Optical_activity	The optical activity shall be described based on a controlled vocabulary. EXAMPLE: (+), (-), (+/-)
	Molecular_formula	The molecular formula shall be provided.
		The isotope section The isotope shall be described in this section, where applicable.
isotope	Nuclide_id	The identifier for each nuclide shall be provided based on a controlled vocabulary.
	Nuclide_name	The name for the nuclide shall be provided.
	Substitution_type	The type of substitution shall be described using a controlled vocabulary. EXAMPLE: specific; non-specific; unknown

SSI level	Data element name	Data element description
protein		<p>The protein section</p> <p>The identifying characteristics of the protein shall be specified in this section.</p>
	Sequence_type	<p>The type of the protein sequence shall be specified based on a controlled vocabulary.</p> <p>EXAMPLE: complete; partial protein descriptive elements will only be used when a complete or partial amino acid sequence is available or derivable from a nucleic acid sequence.</p>
	Number_of_subunits	<p>The number of linear sequences of amino acids linked through peptide bonds shall be described.</p>
	Disulfide_linkage	<p>The position of the disulfide bonds in the protein shall be described in increasing order of subunit number and position within subunit.</p>
	Comment	<p>Additional comments on the protein characteristics can be described.</p>
protein_subunit		<p>The protein subunit section</p>
	Subunit	<p>The numeric value that relates back to the subunit shall be specified in order of decreasing length.</p> <p>Sequences of the same length will be ordered by molecular weight.</p> <p>Subunits that have identical sequences will be repeated and have sequential subscripts.</p> <p>EXAMPLE: 1,2,3,..</p>
	Sequence	<p>Sequences shall be described using the standard single letter amino acid code.</p> <p>Transcribed proteins will always be described using the translated sequence.</p> <p>For synthetic peptides containing amino acids that are not represented with a single letter code an x will be used within the sequence.</p>

SSI level	Data element name	Data element description
	Length	The number of amino acid residues linked through peptide bonds shall be specified.
	N_terminal_modification	The modification at the n-terminal of the protein shall be provided based on a controlled vocabulary. EXAMPLE: acetyl, formyl
	N_terminal_modification_id	The unique identifier related to the modification at the n-terminal of the protein shall be provided.
	C_terminal_modification	The modification at the c-terminal of the protein shall be provided based on a controlled vocabulary. EXAMPLE: amide, ethyl ester
	C_terminal_modification_id	The unique identifier related to the modification at the c-terminal of the protein shall be provided.
glycosylation		The glycosilation section Details on the glycosilation shall be provided.
	Glycosylation_type	The type of the glycosilation shall be specified based on a controlled vocabulary. EXAMPLE: human, mammalian, avian, fungal, bacterial, viral, plant, insect
	N_glycosylation	The site of n-glycosylation shall be described according to the protein sequence. The extent and type of the modification at a given site is not captured. EXAMPLE: asparagine
	O_glycosylation	The site of the o-glycosylation shall be described. EXAMPLE: serine, threonine, etc
	C_glycosylation	The site of the c-glycosylation shall be described. EXAMPLE: tryptophan
modification		The modification section The modification details shall be specified.

SSI level	Data element name	Data element description
	Modification_type	The type of the modification shall be provided based on a controlled vocabulary. EXAMPLE: enzymatic
	Residue_modified	The residue modified shall be described based on controlled vocabulary. EXAMPLES: 20 amino acids plus 5 nucleotides
	Residue_site	The position of specific modifications shall be described. EXAMPLE: 1_10 refers to the 10th residue on the 1st subunit
physical_modification		The physical modification section
	Role	The role of the physical modification shall be provided based on a controlled vocabulary. EXAMPLE: inactivation, activation
	Number_of_parameters	The number of parameter describing the physical modification shall be provided.
parameter		The parameter section
	Parameter	The parameter shall be described based on controlled vocabulary. EXAMPLE: time, temperature
	Amount_type	The type of the amount based on a controlled vocabulary shall be specified. EXAMPLE: mole ratio, weight percent
amount		The amount section
	Average	The average amount or single value of the substance shall be specified.
	Low_limit	The lower limit of the substance shall be specified, where available.
	High_limit	The higher limit of the substance shall be specified, where available.
	Unit	The applicable unit for the amount shall be specified.

SSI level	Data element name	Data element description
	Non_numeric_value	The non numeric value shall be specified based on a controlled vocabulary.
structural_modification		The structural modification section
	Structural_modification_type	The type of the structural modification shall be described based on a controlled vocabulary example: moiety, molecular fragment
moiety		The moiety section
	Moiety_role	The role of the moiety shall be described based on a controlled vocabulary. EXAMPLE: antigen, linker, conjugate
	Moiety_id	The unique identifier of the moiety shall be provided.
	Moiety_name	The name of the moiety shall be provided.
	Amount_type	The type of the amount based on a controlled vocabulary. EXAMPLE: mole ratio, weight percent
amount		The amount section
	Average	The average amount or single value of the substance shall be specified.
	Low_limit	The lower limit of the substance shall be specified, where available.
	High_limit	The higher limit of the substance shall be specified, where available.
	Unit	The applicable unit for the amount shall be specified.
	Non_numeric_value	The non numeric value shall be specified based on a controlled vocabulary.
molecular_fragment		The molecular fragment section
	Role	The role of the molecular fragment shall be described based on a controlled vocabulary. EXAMPLE: antigen, linker, conjugate

SSI level	Data element name	Data element description
	Molecular_fragment_id	The unique identifier for molecular fragment shall be provided.
	Molecular_fragment_name	The name for molecular fragment shall be specified.
	Amount_type	The type of the amount based on a controlled vocabulary. EXAMPLE: mole ratio, weight percent
amount		The amount section
	Average	The average amount or single value of the substance shall be specified.
	Low_limit	The lower limit of the substance shall be specified, where available.
	High_limit	The higher limit of the substance shall be specified, where available.
	Unit	The applicable unit for the amount shall be specified.
	Non_numeric_value	The non numeric value shall be specified based on a controlled vocabulary.
agent_modification		The modification agent section
	Agent_modification_type	The type of the agent used for the modification shall be specified based on a controlled vocabulary. EXAMPLE: chemical, enzymatic, immunological, organismal
	Role	The role of the modification agent shall be specified based on a controlled vocabulary. EXAMPLE: inactivation, activation, pegylation, phosphorylation
	Modification_agent	The name of modifying agent shall be specified.
	Modification_agent_id	The unique identifier of modifying agent shall be provided.
	Modification_process	The modification process shall be specified based on a controlled vocabulary. EXAMPLE: cell culture, UV irradiation

SSI level	Data element name	Data element description
	Amount_type	The type of the amount based on a controlled vocabulary shall be specified. EXAMPLE: mole ratio, weight percent
amount		The amount section
	Average	The average amount or single value of the substance shall be specified.
	Low_limit	The lower limit of the substance shall be specified, where available.
	High_limit	The higher limit of the substance shall be specified, where available.
	Unit	The applicable unit for the amount shall be specified.
	Non_numeric_value	The non numeric value shall be specified based on a controlled vocabulary.
molecular_weight		The molecular weight section
	Molecular_weight_method	The method used to measure the molecular weight shall be specified based on a controlled vocabulary. Example: sds_page, calculated, light scattering viscosity, gel permeation
	Molecular_weight_type	The type of the molecular weight shall be specified based on a controlled vocabulary. Example: exact, average (aka. Number average), weight average
	Amount_type	The type of the amount based on a controlled vocabulary shall be specified. EXAMPLE: mole ratio, weight percent
amount		The amount section
	Average	The average amount or single value of the substance shall be specified.
	Low_limit	The lower limit of the substance shall be specified, where available.
	High_limit	The higher limit of the substance shall be specified, where available.

SSI level	Data element name	Data element description
	Unit	The applicable unit for the amount shall be specified.
	Non_numeric_value	The non numeric value shall be specified based on a controlled vocabulary.
reference_source		The reference source section This section described the reference sources of the information.
	Public_domain	It shall be specified if the reference source information is public or not. Yes or No values apply.
	Reference_source_type	The type of the reference source shall be specified based on a controlled vocabulary.
	Reference_source_class	The class of the reference source shall be specified based on a controlled vocabulary. EXAMPLE: public, regulatory submission
	Reference_source_id	The reference source identifier shall be specified.
	Reference_source_citation	The literature or regulatory document reference shall be referenced.
property		The property section The characteristics of the property shall be described.
	Property_type	The type of property shall be specified based on a controlled vocabulary. EXAMPLE: physical, chemical, enzymatic, immunological
	Property_name	The name of property shall be specified.
	Substance_id	The identifier of the substance related to a defining property shall be described. EXAMPLE: for cell surface antigens, the substance id for cd4 would be captured to define cd4 positive cells

SSI level	Data element name	Data element description
	Substance_name	The name of the substance related to a defining property shall be described. EXAMPLE: for cell surface antigens
	Amount_type	The type of the amount based on a controlled vocabulary shall be specified. EXAMPLE: mole ratio, weight percent
amount		The amount section
	Average	The average amount or single value of the substance shall be specified.
	Low_limit	The lower limit of the substance shall be specified, where available.
	High_limit	The higher limit of the substance shall be specified, where available.
	Unit	The applicable unit for the amount shall be specified.
	Non_numeric_value	The non numeric value shall be specified based on a controlled vocabulary.

4.2.5. SSI for structurally diverse substances

For substances that can be classified as structurally diverse, the following data elements shall be specified:

SSI level	Data element name	Data element description
Substance		
	Substance ID	The unique identifier assigned to the substance.
substance_name		The substance name section This section contains the set of elements for the description of the name of the substance.
	Substance_name	The name of the substance shall be specified.
	Substance_name_type	The type of the name shall be specified based on a controlled vocabulary. EXAMPLE: code, brand name, established name, primary name, other name.

SSI level	Data element name	Data element description
	Language	The language of the substance name shall be specified according to ISO 639-2 alpha-3 codes.
official_name		The official name section
	Official_name_type	The type of the official name shall be specified based on a controlled vocabulary. EXAMPLE: USAN, INN, JAN, BAN, USP, EP, INCI, JECFA
	Official_name_status	The status of the official name shall be specified based on a controlled vocabulary. EXAMPLE: current, alternate, superceded, proposed
	Official_name_status_change_date	The change date of the status of the official name shall be specified in line with the ISO 8601 date format, which shall be only entered when name is changed.
official_name_domain		The official domain name section
	Official_name_domain	The domain of the name shall be provided based on a controlled vocabulary. EXAMPLE: biologic
official_name_jurisdiction		The jurisdiction of the official name section
	Official_name_jurisdiction	The jurisdiction of the official name shall be provided based on ISO 3166-1 alpha-2 codes with two exceptions: EL (not GR) is used to represent Greece, and UK (not GB) is used to represent the United Kingdom.
reference_source		The reference source section This section describes the reference source information.
	Public_domain	It shall be specified if the reference source information is public or not. Yes or No values apply.
	Reference_source_type	The type of the reference source shall be specified based on a controlled vocabulary. EXAMPLE: INN

SSI level	Data element name	Data element description
	Reference_source_class	The class of the reference source shall be specified based on a controlled vocabulary. EXAMPLE: public, regulatory submission
	Reference_source_id	The reference source identifier shall be specified.
	Reference_source_citation	The literature or regulatory document reference shall be described.
substance_code		The substance code section This section describes the code system(s) that apply to a substance.
	Code	The specific code with regard to a referenced code system shall be provided.
	Code_system	The code system shall be specified based on a controlled vocabulary EXAMPLE: CAS, EINECS, NSC, ASK, ATC, Ndf-Rt; Rx-Cui
	Code_system_id	The identifier for the code system shall be provided based on a controlled vocabulary.
	Code_system_status	The status of the code system shall be specified based on a controlled vocabulary. EXAMPLE: current, alternate, superceded.
	Code_system_change_date	The change date of the code system shall be specified in line with the ISO 8601 date format, where applicable. This shall be generated when the status changes.
	Comment	Any comment shall be provided in this field, if required.
reference_source		The reference source section This section described the reference sources of the information.

SSI level	Data element name	Data element description
	Public_domain	It shall be specified if the reference source information is public or not. Yes or No values apply.
	Reference_source_type	The type of the reference source shall be specified based on a controlled vocabulary.
	Reference_source_class	The class of the reference source shall be specified based on a controlled vocabulary. EXAMPLE: public, regulatory submission
	Reference_source_id	The reference source identifier shall be specified.
	Reference_source_citation	The literature or regulatory document reference shall be referenced.
version		The version section This section shall provide information on the version of the substance information.
	Version_number	The number of the version of the SSI shall be provided.
	Effective_date	The date when the SSI was effective shall be provided in line with the ISO 8601 date format. This shall be defined when the SSI is generated or modified.
	Change_made	The description of the updates or changes of the SSI shall be specified.
reference_information		The reference information section This section is used to provide details about the reference information.
	Comment	Additional information as regards the applicable references can be specified.
substance_classification		The substance classification

SSI level	Data element name	Data element description
	Domain	The domain of the substance classification shall be provided based on a controlled vocabulary. EXAMPLE: vaccine, colorant, flavor
	Substance_classification	The substance classification shall be provided based on a controlled vocabulary. EXAMPLE: hmg-coeductase inhibitor
	Substance_classification_type	The type of the classification applied shall be provided based on a controlled vocabulary. EXAMPLE: WHO-ATC, NDF-RT
	Substance_classification_code	The code of the classification type shall be specified based on a controlled vocabulary. EXAMPLE: ATC code, NDF-RT code
subtype		The subtype section
	Substance_class_subtype	The sub-type of the classification shall be described based on a controlled vocabulary. EXAMPLE: human, viral, bacteria, fungal
reference_source		The reference source section This section described the reference sources of the information.
	Public_domain	It shall be specified if the reference source information is public or not. Yes or No values apply.
	Reference_source_type	The type of the reference source shall be specified based on a controlled vocabulary.
	Reference_source_class	The class of the reference source shall be specified based on a controlled vocabulary. EXAMPLE: public, regulatory submission
	Reference_source_id	The reference source identifier shall be specified.
	Reference_source_citation	The literature or regulatory document reference shall be referenced.

SSI level	Data element name	Data element description
substance_relationship		The substance relationship This section shall provide information related to relationship of a substance, where this is applicable.
	Relationship	The relationship of a substance shall be defined based on a controlled vocabulary. EXAMPLE: active moiety, constituent, impurity, degradant, may contain, metabolite, target, transporter, metabolic enzyme, gene element, etc
	Interaction_type	The type of interaction shall be specified based on a controlled vocabulary, where applicable. EXAMPLE: substrate, agonist, partial agonist, antagonist
	Substance_id	The substance identifier, for which the relationship is specified, shall be described.
	Substance_name	The substance name shall be specified.
	Amount_type	The type of the amount of the substance shall be specified using a controlled vocabulary. EXAMPLE: mole ratio, weight percent
	amount	
Average		The average amount or single value of the substance shall be specified.
Low_limit		The lower limit of the substance shall be specified, where available.
High_limit		The higher limit of the substance shall be specified, where available.
Unit		The applicable unit for the amount shall be specified.
	Non_numeric_value	The non numeric value shall be specified based on a controlled vocabulary.
reference_source		The reference source section This section described the reference sources of the information.

SSI level	Data element name	Data element description
	Public_domain	It shall be specified if the reference source information is public or not. Yes or No values apply.
	Reference_source_type	The type of the reference source shall be specified based on a controlled vocabulary.
	Reference_source_class	The class of the reference source shall be specified based on a controlled vocabulary. EXAMPLE: public, regulatory submission
	Reference_source_id	The reference source identifier shall be specified.
	Reference_source_citation	The literature or regulatory document reference shall be referenced.
gene		The gene section This section shall provide a description of the gene in relation to a substance, where applicable.
	Gene_sequence_origin	The common name for the organism from which the final gene sequence originated shall be specified; this applies primarily to proteins.
	Gene_id	The identifier of the gene shall be provided.
	Gene_name	The complete name given for a gene shall be provided.
reference_source		The reference source section This section described the reference sources of the information.
	Public_domain	It shall be specified if the reference source information is public or not. Yes or No values apply.
	Reference_source_type	The type of the reference source shall be specified based on a controlled vocabulary.

SSI level	Data element name	Data element description
	Reference_source_class	The class of the reference source shall be specified based on a controlled vocabulary. EXAMPLE: public, regulatory submission
	Reference_source_id	The reference source identifier shall be specified.
	Reference_source_citation	The literature or regulatory document reference shall be referenced.
gene_element		The gene element section
	Gene_element_type	The type of the gene element shall be specified based on a controlled vocabulary. EXAMPLE: enhancer, promoter, silencer, terminator, repressor (..)
	Gene_element_id	The unique identifier for the gene element shall be specified based on a controlled vocabulary.
	Gene_element_name	The specific gene element name shall be described based on a controlled vocabulary.
reference_source		The reference source section This section described the reference sources of the information.
	Public_domain	It shall be specified if the reference source information is public or not. Yes or No values apply.
	Reference_source_type	The type of the reference source shall be specified based on a controlled vocabulary.
	Reference_source_class	The class of the reference source shall be specified based on a controlled vocabulary. EXAMPLE: public, regulatory submission
	Reference_source_id	The reference source identifier shall be specified.
	Reference_source_citation	The literature or regulatory document reference shall be referenced.

SSI level	Data element name	Data element description
target		The target section This section shall provide information on the target substance.
	Target_gene_id	The identifier of the target gene shall be provided.
	Target_gene_name	The target gene name shall be specified based on a controlled vocabulary. EXAMPLE: single substance, a pathway, an enzyme type
	Interaction_type	The type of interaction shall be specified based on a controlled vocabulary. EXAMPLE: inhibitor, inducer
	Target_organism_type	The type of target organism shall be specified based on a controlled vocabulary. EXAMPLE: human, viral, bacteria, fungal
	Target_type	The target type shall be specified based on a controlled vocabulary. EXAMPLE: enzyme, receptor, membrane
reference_source		The reference source section This section described the reference sources of the information.
	Public_domain	It shall be specified if the reference source information is public or not. Yes or No values apply.
	Reference_source_type	The type of the reference source shall be specified based on a controlled vocabulary.
	Reference_source_class	The class of the reference source shall be specified based on a controlled vocabulary. EXAMPLE: public, regulatory submission
	Reference_source_id	The reference source identifier shall be specified.
	Reference_source_citation	The literature or regulatory document reference shall be referenced.

SSI level	Data element name	Data element description
structure		The structure section The structure of the substance shall be described, where applicable
	Structural_representation_type	The type of the structural representation shall be described based on a controlled vocabulary. EXAMPLE: inchi, mol file
	Structural_representation	The structural representation shall be provided.
	Structural_representation_attachment	A copy of the structural representation shall be provided.
	Stereochemistry	The stereochemistry of the substance shall be described based on a controlled vocabulary. EXAMPLE: racemic; meso; mixed; unknown; axial, absolute; achiral (cis/trans or geometric isomerism indicated in structure)
	Optical_activity	The optical activity shall be described based on a controlled vocabulary. EXAMPLE: (+), (-), (+/-)
	Molecular_formula	The molecular formula shall be provided.
		The isotope section The isotope shall be described in this section, where applicable.
		Nuclide_id
	Nuclide_name	The name for the nuclide shall be provided.
	Substitution_type	The type of substitution shall be described using a controlled vocabulary. EXAMPLE: specific; non-specific; unknown

SSI level	Data element name	Data element description
structurally_Diverse_Substance		The structurally diverse substance section The identifying characteristics of the structurally diverse substances shall be specified.
	Comment	Additional characteristics for the structurally diverse substance can be specified.
modification		The modification section The modification details shall be specified.
	Modification_type	The type of the modification shall be provided based on a controlled vocabulary. EXAMPLE: enzymatic
	Residue_modified	The residue modified shall be described based on controlled vocabulary. EXAMPLES: 20 amino acids plus 5 nucleotides
	Residue_site	The position of specific modifications shall be described. EXAMPLE: 1_10 refers to the 10th residue on the 1st subunit
physical_modification		The physical modification section
	Role	The role of the physical modification shall be provided based on a controlled vocabulary. EXAMPLE: inactivation, activation
	Number_of_parameters	The number of parameter describing the physical modification shall be provided.
parameter		The parameter section
	Parameter	The parameter shall be described based on controlled vocabulary. EXAMPLE: time, temperature
	Amount_type	The type of the amount based on a controlled vocabulary shall be specified. EXAMPLE: mole ratio, weight percent

SSI level	Data element name	Data element description
amount		The amount section
	Average	The average amount or single value of the substance shall be specified.
	Low_limit	The lower limit of the substance shall be specified, where available.
	High_limit	The higher limit of the substance shall be specified, where available.
	Unit	The applicable unit for the amount shall be specified.
	Non_numeric_value	The non numeric value shall be specified based on a controlled vocabulary.
structural_modification		The structural modification section
	Structural_modification_type	The type of the structural modification shall be described based on a controlled vocabulary example: moiety, molecular fragment
moiety		The moiety section
	Moiety_role	The role of the moiety shall be described based on a controlled vocabulary. EXAMPLE: antigen, linker, conjugate
	Moiety_id	The unique identifier of the moiety shall be provided.
	Moiety_name	The name of the moiety shall be provided.
	Amount_type	The type of the amount based on a controlled vocabulary. EXAMPLE: mole ratio, weight percent
amount		The amount section
	Average	The average amount or single value of the substance shall be specified.
	Low_limit	The lower limit of the substance shall be specified, where available.
	High_limit	The higher limit of the substance shall be specified, where available.
	Unit	The applicable unit for the amount shall be specified.

SSI level	Data element name	Data element description
	Non_numeric_value	The non numeric value shall be specified based on a controlled vocabulary.
molecular_fragment		The molecular fragment section
	Role	The role of the molecular fragment shall be described based on a controlled vocabulary. EXAMPLE: antigen, linker, conjugate
	Molecular_fragment_id	The unique identifier for molecular fragment shall be provided.
	Molecular_fragment_name	The name for molecular fragment shall be specified.
	Amount_type	The type of the amount based on a controlled vocabulary. EXAMPLE: mole ratio, weight percent
amount		The amount section
	Average	The average amount or single value of the substance shall be specified.
	Low_limit	The lower limit of the substance shall be specified, where available.
	High_limit	The higher limit of the substance shall be specified, where available.
	Unit	The applicable unit for the amount shall be specified.
	Non_numeric_value	The non numeric value shall be specified based on a controlled vocabulary.
agent_modification		The modification agent section
	Agent_modification_type	The type of the agent used for the modification shall be specified based on a controlled vocabulary. EXAMPLE: chemical, enzymatic, immunological, organismal
	Role	The role of the modification agent shall be specified based on a controlled vocabulary. EXAMPLE: inactivation, activation, pegylation, phosphorylation

SSI level	Data element name	Data element description
	Modification_agent	The name of modifying agent shall be specified.
	Modification_agent_id	The unique identifier of modifying agent shall be provided.
	Modification_process	The modification process shall be specified based on a controlled vocabulary. EXAMPLE: cell culture, UV irradiation
	Amount_type	The type of the amount based on a controlled vocabulary shall be specified. EXAMPLE: mole ratio, weight percent
amount		The amount section
	Average	The average amount or single value of the substance shall be specified.
	Low_limit	The lower limit of the substance shall be specified, where available.
	High_limit	The higher limit of the substance shall be specified, where available.
	Unit	The applicable unit for the amount shall be specified.
	Non_numeric_value	The non numeric value shall be specified based on a controlled vocabulary.
source_material		The source material section The source material shall be specified in this section.
	Source_material_classes	The classification of the source material shall be specified based on controlled vocabulary. EXAMPLE: organism, mineral
	Source_material_type	The type of the source material shall be specified based on controlled vocabulary. For vaccines this is the class of infectious agent. EXAMPLE: bacterium, human, mammal, fungus, virus, plant, virus

SSI level	Data element name	Data element description
	Source_material_state	The state of the source material shall be specified based on controlled vocabulary. EXAMPLE: live, activated, inactivated, attenuated, conjugated, live (attenuated).
	Organism_name_id	The unique identifier associated with the source material parent organism shall be specified.
	Organism_name	The organism accepted Latin name shall be provided.
	Developmental_stage	The developmental stage shall be defined based on a controlled vocabulary. EXAMPLE: foetus, infant, juvenile, adult, senescent, leafing, pre-flowering, flowering, fruiting
part		The part section
	Part	The portion of an organism with a definable anatomical location shall be described based on a controlled vocabulary.
	Part_location	The anatomical location shall be specified based on a controlled vocabulary.
fraction		The fraction section
	Material_type	The material type shall be specified based on a controlled vocabulary. EXAMPLE: cell, protein, polysaccharide, nucleic acid, expressed oil, essential oil
	Fraction	The fraction shall be specified based on a controlled vocabulary.
organism		The organism section The organism shall be defined based on specific elements defined in this section.

SSI level	Data element name	Data element description
	Kingdom	The kingdom of an organism shall be specified based on a controlled vocabulary.
	Phylum	The phylum of an organism shall be specified based on a controlled vocabulary.
	Class	The class of an organism shall be specified based on a controlled vocabulary.
	Order	The order of an organism shall be specified based on a controlled vocabulary.
	Family	The family of an organism shall be specified based on a controlled vocabulary.
	Genus	The genus of an organism shall be specified based on a controlled vocabulary.
	Species	The species of an organism shall be specified based on a controlled vocabulary.
	Species_parenthetical_author	The parenthetical author of an organism species shall be specified based on a controlled vocabulary.
	Species_parenthetical_author_year	The parenthetical author year of an organism species an organism shall be specified based on a controlled vocabulary.
	Species_primary_auth or	The primary author of an organism species shall be specified based on a controlled vocabulary.
	Species_primary_auth or_year	The primary author year of an organism species shall be specified based on a controlled vocabulary.
	Hybrid_species_mater nal_organism_id	The identifier of the maternal species constituting the hybrid organism shall be specified based on a controlled vocabulary.
	Hybrid_species_pater nal_organism_id	The identifier of the paternal species constituting the hybrid organism shall be specified based on a controlled vocabulary.

SSI level	Data element name	Data element description
	Hybrid_type	The hybrid type of an organism shall be defined. EXAMPLE: yes/no
	Infraspecific_type	The infraspecific type of an organism shall be specified based on a controlled vocabulary.
	Infraspecific_descripti	The infraspecific type of an organism shall be specified based on a controlled vocabulary.
	Infraspecific_parenthe tical_author	The infraspecific parenthetical author of an organism shall be specified based on a controlled vocabulary.
	Infraspecific_parenthe tical_author_year	The infraspecific parenthetical author year of an organism shall be specified based on a controlled vocabulary.
	Infraspecific_primary _author	The infraspecific primary author of an organism shall be specified based on a controlled vocabulary.
	Infraspecific_primary _author_year	The infraspecific primary author year of an organism shall be specified based on a controlled vocabulary.
property		The property section The characteristics of the property shall be described.
	Property_type	The type of property shall be specified based on a controlled vocabulary. EXAMPLE: physical, chemical, enzymatic, immunological
	Property_name	The name of property shall be specified.
	Substance_id	The identifier of the substance related to a defining property shall be described. EXAMPLE: for cell surface antigens, the substance id for cd4 would be captured to define cd4 positive cells
	Substance_name	The name of the substance related to a defining property shall be described. EXAMPLE: for cell surface antigens

SSI level	Data element name	Data element description
	Amount_type	The type of the amount based on a controlled vocabulary shall be specified. EXAMPLE: mole ratio, weight percent
amount		The amount section
	Average	The average amount or single value of the substance shall be specified.
	Low_limit	The lower limit of the substance shall be specified, where available.
	High_limit	The higher limit of the substance shall be specified, where available.
	Unit	The applicable unit for the amount shall be specified.
	Non_numeric_value	The non numeric value shall be specified based on a controlled vocabulary.
glycosylation		The glycosilation section
	Glycosylation_type	The type of the glycosilation shall be specified based on a controlled vocabulary. EXAMPLE: human, mammalian, avian, fungal, bacterial, viral, plant, insect
	N_glycosylation	The site of n-glycosylation shall be described according to the protein sequence. The extent and type of modification at a given site is not captured. EXAMPLE: asparagine
	O_glycosylation	The site of the o-glycosylation shall be described. EXAMPLE: serine, threonine, etc
	C_glycosylation	The site of the c-glycosylation shall be described. EXAMPLE: tryptophan
molecular_weight		The molecular weight section

SSI level	Data element name	Data element description
	Molecular_weight_method	The method used to measure the molecular weight shall be specified based on a controlled vocabulary. Example: sds_page, calculated, light scattering viscosity, gel permeation
	Molecular_weight_type	The type of the molecular weight shall be specified based on a controlled vocabulary. Example: exact, average (aka. Number average), weight average
	Amount_type	The type of the amount based on a controlled vocabulary shall be specified. EXAMPLE: mole ratio, weight percent
amount		The amount section
	Average	The average amount or single value of the substance shall be specified.
	Low_limit	The lower limit of the substance shall be specified, where available.
	High_limit	The higher limit of the substance shall be specified, where available.
	Unit	The applicable unit for the amount shall be specified.
	Non_numeric_value	The non numeric value shall be specified based on a controlled vocabulary.
reference_source		The reference source section This section described the reference sources of the information.
	Public_domain	It shall be specified if the reference source information is public or not. Yes or No values apply.
	Reference_source_type	The type of the reference source shall be specified based on a controlled vocabulary.

SSI level	Data element name	Data element description
	Reference_source_classes	The class of the reference source shall be specified based on a controlled vocabulary. EXAMPLE: public, regulatory submission
	Reference_source_id	The reference source identifier shall be specified.
	Reference_source_citation	The literature or regulatory document reference shall be referenced.

4.2.6. SSI for mixture substances

For substances that can be classified as a mixture substance, the following data elements shall be specified:

SSI level	Data Element Name	Data Element Description
	Substance ID	The unique identifier assigned to the substance.
substance_name		The substance name section This section contains the set of elements for the description of the name of the substance.
	Substance_name	The name of the substance shall be specified.
	Substance_name_type	The type of the name shall be specified based on a controlled vocabulary. EXAMPLE: code, brand name, established name, primary name, other name.
	Language	The language of the substance name shall be specified according to ISO 639-2 alpha-3 codes.
official_name		The official name section
	Official_name_type	The type of the official name shall be specified based on a controlled vocabulary. EXAMPLE: USAN, INN, JAN, BAN, USP, EP, INCI, JECFA

SSI level	Data Element Name	Data Element Description
	Official_name_status	The status of the official name shall be specified based on a controlled vocabulary. EXAMPLE: current, alternate, superceded, proposed
	Official_name_status_change_date	The change date of the status of the official name shall be specified in line with the ISO 8601 date format, which shall be only entered when name is changed.
official_name_domain		The official domain name section
	Official_name_domain	The domain of the name shall be provided based on a controlled vocabulary. EXAMPLE: biologic
official_name_jurisdiction		The jurisdiction of the official name section
	Official_name_jurisdiction	The jurisdiction of the official name shall be provided based on ISO 3166-1 alpha-2 codes with two exceptions: EL (not GR) is used to represent Greece, and UK (not GB) is used to represent the United Kingdom.
reference_source		The reference source section This section describes the reference source information.
	Public_domain	It shall be specified if the reference source information is public or not. Yes or No values apply.
	Reference_source_type	The type of the reference source shall be specified based on a controlled vocabulary. EXAMPLE: INN
	Reference_source_class	The class of the reference source shall be specified based on a controlled vocabulary. EXAMPLE: public, regulatory submission
	Reference_source_id	The reference source identifier shall be specified.
	Reference_source_citation	The literature or regulatory document reference shall be described.

SSI level	Data Element Name	Data Element Description
substance_code		The substance code section This section describes the code system(s) that apply to a substance.
	Code	The specific code with regard to a referenced code system shall be provided.
	Code_system	The code system shall be specified based on a controlled vocabulary EXAMPLE: CAS, EINECS, NSC, ASK, ATC, Ndf-Rt; Rx-Cui
	Code_system_id	The identifier for the code system shall be provided based on a controlled vocabulary.
	Code_system_status	The status of the code system shall be specified based on a controlled vocabulary. EXAMPLE: current, alternate, superceded.
	Code_system_change_date	The change date of the code system shall be specified in line with the ISO 8601 date format, where applicable. This shall be generated when the status changes.
	Comment	Any comment shall be provided in this field, if required.
	reference_source	
Public_domain		It shall be specified if the reference source information is public or not. Yes or No values apply.
Reference_source_type		The type of the reference source shall be specified based on a controlled vocabulary.
Reference_source_class		The class of the reference source shall be specified based on a controlled vocabulary. EXAMPLE: public, regulatory submission

SSI level	Data Element Name	Data Element Description
	Reference_source_id	The reference source identifier shall be specified.
	Reference_source_citation	The literature or regulatory document reference shall be referenced.
version		The version section This section shall provide information on the version of the substance information.
	Version_number	The number of the version of the SSI shall be provided.
	Effective_date	The date when the SSI was effective shall be provided in line with the ISO 8601 date format. This shall be defined when the SSI is generated or modified.
	Change_made	The description of the updates or changes of the SSI shall be specified.
reference_information		The reference information section This section is used to provide details about the reference information.
	Comment	Additional information as regards the applicable references can be specified.
substance_classification		The substance classification
	Domain	The domain of the substance classification shall be provided based on a controlled vocabulary. EXAMPLE: vaccine, colorant, flavor
	Substance_classification	The substance classification shall be provided based on a controlled vocabulary. EXAMPLE: hmg-coreductase inhibitor
	Substance_classification_type	The type of the classification applied shall be provided based on a controlled vocabulary. EXAMPLE: WHO-ATC, NDF-RT

SSI level	Data Element Name	Data Element Description
	Substance_classification_code	The code of the classification type shall be specified based on a controlled vocabulary. EXAMPLE: ATC code, NDF-RT code
subtype		The subtype section
	Substance_class_subtype	The sub-type of the classification shall be described based on a controlled vocabulary. EXAMPLE: human, viral, bacteria, fungal
reference_source		The reference source section This section described the reference sources of the information.
	Public_domain	It shall be specified if the reference source information is public or not. Yes or No values apply.
	Reference_source_type	The type of the reference source shall be specified based on a controlled vocabulary.
	Reference_source_class	The class of the reference source shall be specified based on a controlled vocabulary. EXAMPLE: public, regulatory submission
	Reference_source_id	The reference source identifier shall be specified.
	Reference_source_citation	The literature or regulatory document reference shall be referenced.
substance_relationship		The substance relationship This section shall provide information related to relationship of a substance, where this is applicable.
	Relationship	The relationship of a substance shall be defined based on a controlled vocabulary. EXAMPLE: active moiety, constituent, impurity, degradant, may contain, metabolite, target, transporter, metabolic enzyme, gene element, etc

SSI level	Data Element Name	Data Element Description
	Interaction_type	The type of interaction shall be specified based on a controlled vocabulary, where applicable. EXAMPLE: substrate, agonist, partial agonist, antagonist
	Substance_id	The substance identifier, for which the relationship is specified, shall be described.
	Substance_name	The substance name shall be specified.
	Amount_type	The type of the amount of the substance shall be specified using a controlled vocabulary. EXAMPLE: mole ratio, weight percent
amount		The amount section
	Average	The average amount or single value of the substance shall be specified.
	Low_limit	The lower limit of the substance shall be specified, where available.
	High_limit	The higher limit of the substance shall be specified, where available.
	Unit	The applicable unit for the amount shall be specified.
	Non_numeric_value	The non numeric value shall be specified based on a controlled vocabulary.
reference_source		The reference source section This section described the reference sources of the information.
	Public_domain	It shall be specified if the reference source information is public or not. Yes or No values apply.
	Reference_source_type	The type of the reference source shall be specified based on a controlled vocabulary.
	Reference_source_class	The class of the reference source shall be specified based on a controlled vocabulary. EXAMPLE: public, regulatory submission

SSI level	Data Element Name	Data Element Description
	Reference_source_id	The reference source identifier shall be specified.
	Reference_source_citation	The literature or regulatory document reference shall be referenced.
gene		<p>The gene section</p> <p>This section shall provide a description of the gene in relation to a substance, where applicable.</p>
	Gene_sequence_origin	The common name for the organism from which the final gene sequence originated shall be specified; this applies primarily to proteins.
	Gene_id	The identifier of the gene shall be provided.
	Gene_name	The complete name given for a gene shall be provided.
reference_source		<p>The reference source section</p> <p>This section described the reference sources of the information.</p>
	Public_domain	It shall be specified if the reference source information is public or not. Yes or No values apply.
	Reference_source_type	The type of the reference source shall be specified based on a controlled vocabulary.
	Reference_source_class	<p>The class of the reference source shall be specified based on a controlled vocabulary.</p> <p>EXAMPLE: public, regulatory submission</p>
	Reference_source_id	The reference source identifier shall be specified.
	Reference_source_citation	The literature or regulatory document reference shall be referenced.
gene_element		The gene element section

SSI level	Data Element Name	Data Element Description
	Gene_element_type	The type of the gene element shall be specified based on a controlled vocabulary. EXAMPLE: enhancer, promoter, silencer, terminator, repressor (..)
	Gene_element_id	The unique identifier for the gene element shall be specified based on a controlled vocabulary.
	Gene_element_name	The specific gene element name shall be described based on a controlled vocabulary.
reference_source		The reference source section This section described the reference sources of the information.
	Public_domain	It shall be specified if the reference source information is public or not. Yes or No values apply.
	Reference_source_type	The type of the reference source shall be specified based on a controlled vocabulary.
	Reference_source_class	The class of the reference source shall be specified based on a controlled vocabulary. EXAMPLE: public, regulatory submission
	Reference_source_id	The reference source identifier shall be specified.
	Reference_source_citation	The literature or regulatory document reference shall be referenced.
target		The target section This section shall provide information on the target substance.
	Target_gene_id	The identifier of the target gene shall be provided.
	Target_gene_name	The target gene name shall be specified based on a controlled vocabulary. EXAMPLE: single substance, a pathway, an enzyme type

SSI level	Data Element Name	Data Element Description
	Interaction_type	The type of interaction shall be specified based on a controlled vocabulary. EXAMPLE: inhibitor, inducer
	Target_organism_type	The type of target organism shall be specified based on a controlled vocabulary. EXAMPLE: human, viral, bacteria, fungal
	Target_type	The target type shall be specified based on a controlled vocabulary. EXAMPLE: enzyme, receptor, membrane
reference_source		The reference source section This section described the reference sources of the information.
	Public_domain	It shall be specified if the reference source information is public or not. Yes or No values apply.
	Reference_source_type	The type of the reference source shall be specified based on a controlled vocabulary.
	Reference_source_class	The class of the reference source shall be specified based on a controlled vocabulary. EXAMPLE: public, regulatory submission
	Reference_source_id	The reference source identifier shall be specified.
	Reference_source_citation	The literature or regulatory document reference shall be referenced.
mixture_substance		The mixture substance section The identifying characteristics for a mixture substance shall be described.
	Mixture_type	The type of the mixture shall be specified based on a controlled vocabulary. Example: one of, all of, any of

SSI level	Data Element Name	Data Element Description
source_material		The source material section The source material shall be specified in this section.
	Source_material_classes	The classification of the source material shall be specified based on controlled vocabulary. EXAMPLE: organism, mineral
	Source_material_type	The type of the source material shall be specified based on controlled vocabulary. For vaccines this is the class of infectious agent. EXAMPLE: bacterium, human, mammal, fungus, virus, plant, virus
	Source_material_state	The state of the source material shall be specified based on controlled vocabulary. EXAMPLE: live, activated, inactivated, attenuated, conjugated, live (attenuated).
	Organism_name_id	The unique identifier associated with the source material parent organism shall be specified.
	Organism_name	The organism accepted Latin name shall be provided.
	Developmental_stage	The developmental stage shall be defined based on a controlled vocabulary. EXAMPLE: foetus, infant, juvenile, adult, senescent, leafing, pre-flowering, flowering, fruiting
part		The part section
	Part	The portion of an organism with a definable anatomical location shall be described based on a controlled vocabulary.
	Part_location	The anatomical location shall be specified based on a controlled vocabulary.
fraction		The fraction section

SSI level	Data Element Name	Data Element Description
	Material_type	The material type shall be specified based on a controlled vocabulary. EXAMPLE: cell, protein, polysaccharide, nucleic acid, expressed oil, essential oil
	Fraction	The fraction shall be specified based on a controlled vocabulary.
organism		The organism section The organism shall be defined based on specific elements defined in this section.
	Kingdom	The kingdom of an organism shall be specified based on a controlled vocabulary.
	Phylum	The phylum of an organism shall be specified based on a controlled vocabulary.
	Class	The class of an organism shall be specified based on a controlled vocabulary.
	Order	The order of an organism shall be specified based on a controlled vocabulary.
	Family	The family of an organism shall be specified based on a controlled vocabulary.
	Genus	The genus of an organism shall be specified based on a controlled vocabulary.
	Species	The species of an organism shall be specified based on a controlled vocabulary.
	Species_parenthetical_author	The parenthetical author of an organism species shall be specified based on a controlled vocabulary.
	Species_parenthetical_author_year	The parenthetical author year of an organism species an organism shall be specified based on a controlled vocabulary.

SSI level	Data Element Name	Data Element Description
	Species_primary_auth or	The primary author of an organism species shall be specified based on a controlled vocabulary.
	Species_primary_auth or_year	The primary author year of an organism species shall be specified based on a controlled vocabulary.
	Hybrid_species_maternal_organism_id	The identifier of the maternal species constituting the hybrid organism shall be specified based on a controlled vocabulary.
	Hybrid_species_paternal_organism_id	The identifier of the paternal species constituting the hybrid organism shall be specified based on a controlled vocabulary.
	Hybrid_type	The hybrid type of an organism shall be defined. EXAMPLE: yes/no
	Intraspecific_type	The intraspecific type of an organism shall be specified based on a controlled vocabulary.
	Intraspecific_descripti	The intraspecific type of an organism shall be specified based on a controlled vocabulary.
	Intraspecific_parenthetical_author	The intraspecific parenthetical author of an organism shall be specified based on a controlled vocabulary.
	Intraspecific_parenthetical_author_year	The intraspecific parenthetical author year of an organism shall be specified based on a controlled vocabulary.
	Intraspecific_primary_author	The intraspecific primary author of an organism shall be specified based on a controlled vocabulary.
	Intraspecific_primary_author_year	The intraspecific primary author year of an organism shall be specified based on a controlled vocabulary.
modification		The modification section The modification details shall be specified.

SSI level	Data Element Name	Data Element Description
	Modification_type	The type of the modification shall be provided based on a controlled vocabulary. EXAMPLE: enzymatic
	Residue_modified	The residue modified shall be described based on controlled vocabulary. EXAMPLES: 20 amino acids plus 5 nucleotides
	Residue_site	The position of specific modifications shall be described. EXAMPLE: 1_10 refers to the 10th residue on the 1st subunit
physical_modification		The physical modification section
	Role	The role of the physical modification shall be provided based on a controlled vocabulary. EXAMPLE: inactivation, activation
	Number_of_parameters	The number of parameter describing the physical modification shall be provided.
parameter		The parameter section
	Parameter	The parameter shall be described based on controlled vocabulary. EXAMPLE: time, temperature
	Amount_type	The type of the amount based on a controlled vocabulary shall be specified. EXAMPLE: mole ratio, weight percent
amount		The amount section
	Average	The average amount or single value of the substance shall be specified.
	Low_limit	The lower limit of the substance shall be specified, where available.
	High_limit	The higher limit of the substance shall be specified, where available.
	Unit	The applicable unit for the amount shall be specified.
	Non_numeric_value	The non numeric value shall be specified based on a controlled vocabulary.

SSI level	Data Element Name	Data Element Description
structural_modification		The structural modification section
	Structural_modification_type	The type of the structural modification shall be described based on a controlled vocabulary example: moiety, molecular fragment
moiety		The moiety section
	Moiety_role	The role of the moiety shall be described based on a controlled vocabulary. EXAMPLE: antigen, linker, conjugate
	Moiety_id	The unique identifier of the moiety shall be provided.
	Moiety_name	The name of the moiety shall be provided.
	Amount_type	The type of the amount based on a controlled vocabulary. EXAMPLE: mole ratio, weight percent
amount		The amount section
	Average	The average amount or single value of the substance shall be specified.
	Low_limit	The lower limit of the substance shall be specified, where available.
	High_limit	The higher limit of the substance shall be specified, where available.
	Unit	The applicable unit for the amount shall be specified.
	Non_numeric_value	The non numeric value shall be specified based on a controlled vocabulary.
molecular_fragment		The molecular fragment section
	Role	The role of the molecular fragment shall be described based on a controlled vocabulary. EXAMPLE: antigen, linker, conjugate
	Molecular_fragment_id	The unique identifier for molecular fragment shall be provided.
	Molecular_fragment_name	The name for molecular fragment shall be specified.

SSI level	Data Element Name	Data Element Description
	Amount_type	The type of the amount based on a controlled vocabulary. EXAMPLE: mole ratio, weight percent
amount		The amount section
	Average	The average amount or single value of the substance shall be specified.
	Low_limit	The lower limit of the substance shall be specified, where available.
	High_limit	The higher limit of the substance shall be specified, where available.
	Unit	The applicable unit for the amount shall be specified.
	Non_numeric_value	The non numeric value shall be specified based on a controlled vocabulary.
agent_modification		The modification agent section
	Agent_modification_type	The type of the agent used for the modification shall be specified based on a controlled vocabulary. EXAMPLE: chemical, enzymatic, immunological, organismal
	Role	The role of the modification agent shall be specified based on a controlled vocabulary. EXAMPLE: inactivation, activation, pegylation, phosphorylation
	Modification_agent	The name of modifying agent shall be specified.
	Modification_agent_id	The unique identifier of modifying agent shall be provided.
	Modification_process	The modification process shall be specified based on a controlled vocabulary. EXAMPLE: cell culture, UV irradiation
	Amount_type	The type of the amount based on a controlled vocabulary shall be specified. EXAMPLE: mole ratio, weight percent

SSI level	Data Element Name	Data Element Description
amount		The amount section
	Average	The average amount or single value of the substance shall be specified.
	Low_limit	The lower limit of the substance shall be specified, where available.
	High_limit	The higher limit of the substance shall be specified, where available.
	Unit	The applicable unit for the amount shall be specified.
	Non_numeric_value	The non numeric value shall be specified based on a controlled vocabulary.
mixture_constituent		The mixture constituent section The substance constituting the mixture shall be described.
	Constituent_id	The unique identifier of the substance constituting the mixture shall be specified.
	Constituent_name	The name of the substance constituting the mixture shall be specified.
	Constituent_requirement	The requirement of the constituent shall be described based on a controlled vocabulary. EXAMPLE: always present, may be present

4.2.7. SSI for specified substance – group 1

For Specified Substance Group 1, the SSI shall be described based on the following data elements:

Data element level	Data element name	Data element description
specified_substance_group1		The specified substance group 1 section The identifying characteristics for the specified substance group 1 shall be specified.

Data element level	Data element name	Data element description
	Specified_substance_group1_id	The unique identifier of the specified substance shall be described.
	Specified_substance_group1_name	The name of the specified substance group 1 shall be described.
substance		
	Substance ID	The unique identifier assigned to the substance.
substance_name		The substance name section This section contains the set of elements for the description of the name of the substance.
	Substance_name	The name of the substance shall be specified.
	Substance_name_type	The type of the name shall be specified based on a controlled vocabulary. EXAMPLE: code, brand name, established name, primary name, other name.
	Language	The language of the substance name shall be specified according to ISO 639-2 alpha-3 codes.
official_name		The official name section
	Official_name_type	The type of the official name shall be specified based on a controlled vocabulary. EXAMPLE: USAN, INN, JAN, BAN, USP, EP, INCI, JECFA
	Official_name_status	The status of the official name shall be specified based on a controlled vocabulary. EXAMPLE: current, alternate, superceded, proposed
	Official_name_status_change_date	The change date of the status of the official name shall be specified in line with the ISO 8601 date format, which shall be only entered when name is changed.
official_name_domain		The official domain name section

Data element level	Data element name	Data element description
	Official_name_domain	The domain of the name shall be provided based on a controlled vocabulary. EXAMPLE: biologic
official_name_jurisdiction		The jurisdiction of the official name section
	Official_name_jurisdiction	The jurisdiction of the official name shall be provided based on ISO 3166-1 alpha-2 codes with two exceptions: EL (not GR) is used to represent Greece, and UK (not GB) is used to represent the United Kingdom.
reference_source		The reference source section This section describes the reference source information.
	Public_domain	It shall be specified if the reference source information is public or not. Yes or No values apply.
	Reference_source_type	The type of the reference source shall be specified based on a controlled vocabulary. EXAMPLE: INN
	Reference_source_class	The class of the reference source shall be specified based on a controlled vocabulary. EXAMPLE: public, regulatory submission
	Reference_source_id	The reference source identifier shall be specified.
	Reference_source_citation	The literature or regulatory document reference shall be described.
substance_code		The substance code section This section describes the code system(s) that apply to a substance.
	Code	The specific code with regard to a referenced code system shall be provided.

Data element level	Data element name	Data element description
	Code_system	The code system shall be specified based on a controlled vocabulary EXAMPLE: CAS, EINECS, NSC, ASK, ATC, Ndf-Rt; Rx-Cui
	Code_system_id	The identifier for the code system shall be provided based on a controlled vocabulary.
	Code_system_status	The status of the code system shall be specified based on a controlled vocabulary. EXAMPLE: current, alternate, superceded.
	Code_system_change_date	The change date of the code system shall be specified in line with the ISO 8601 date format, where applicable. This shall be generated when the status changes.
	Comment	Any comment shall be provided in this field, if required.
reference_source		The reference source section This section described the reference sources of the information.
	Public_domain	It shall be specified if the reference source information is public or not. Yes or No values apply.
	Reference_source_type	The type of the reference source shall be specified based on a controlled vocabulary.
	Reference_source_class	The class of the reference source shall be specified based on a controlled vocabulary. EXAMPLE: public, regulatory submission
	Reference_source_id	The reference source identifier shall be specified.
	Reference_source_citation	The literature or regulatory document reference shall be referenced.

Data element level	Data element name	Data element description
version		The version section This section shall provide information on the version of the substance information.
	Version_number	The number of the version of the SSI shall be provided.
	Effective_date	The date when the SSI was effective shall be provided in line with the ISO 8601 date format. This shall be defined when the SSI is generated or modified.
	Change_made	The description of the updates or changes of the SSI shall be specified.
reference_information		The reference information section This section is used to provide details about the reference information.
	Comment	Additional information as regards the applicable references can be specified.
substance_classification		The substance classification
	Domain	The domain of the substance classification shall be provided based on a controlled vocabulary. EXAMPLE: vaccine, colorant, flavor
	Substance_classification	The substance classification shall be provided based on a controlled vocabulary. EXAMPLE: hmg-coreductase inhibitor
	Substance_classification_type	The type of the classification applied shall be provided based on a controlled vocabulary. EXAMPLE: WHO-ATC, NDF-RT
	Substance_classification_code	The code of the classification type shall be specified based on a controlled vocabulary. EXAMPLE: ATC code, NDF-RT code
subtype		The subtype section

Data element level	Data element name	Data element description
	Substance_class_subtype	The sub-type of the classification shall be described based on a controlled vocabulary. EXAMPLE: human, viral, bacteria, fungal
reference_source		The reference source section This section described the reference sources of the information.
	Public_domain	It shall be specified if the reference source information is public or not. Yes or No values apply.
	Reference_source_type	The type of the reference source shall be specified based on a controlled vocabulary.
	Reference_source_class	The class of the reference source shall be specified based on a controlled vocabulary. EXAMPLE: public, regulatory submission
	Reference_source_id	The reference source identifier shall be specified.
	Reference_source_citation	The literature or regulatory document reference shall be referenced.
substance_relationship		The substance relationship This section shall provide information related to relationship of a substance, where this is applicable.
	Relationship	The relationship of a substance shall be defined based on a controlled vocabulary. EXAMPLE: active moiety, constituent, impurity, degradant, may contain, metabolite, target, transporter, metabolic enzyme, gene element, etc
	Interaction_type	The type of interaction shall be specified based on a controlled vocabulary, where applicable. EXAMPLE: substrate, agonist, partial agonist, antagonist

Data element level	Data element name	Data element description
	Substance_id	The substance identifier, for which the relationship is specified, shall be described.
	Substance_name	The substance name shall be specified.
	Amount_type	The type of the amount of the substance shall be specified using a controlled vocabulary. EXAMPLE: mole ratio, weight percent
amount		The amount section
	Average	The average amount or single value of the substance shall be specified.
	Low_limit	The lower limit of the substance shall be specified, where available.
	High_limit	The higher limit of the substance shall be specified, where available.
	Unit	The applicable unit for the amount shall be specified.
	Non_numeric_value	The non numeric value shall be specified based on a controlled vocabulary.
reference_source		The reference source section This section described the reference sources of the information.
	Public_domain	It shall be specified if the reference source information is public or not. Yes or No values apply.
	Reference_source_type	The type of the reference source shall be specified based on a controlled vocabulary.
	Reference_source_class	The class of the reference source shall be specified based on a controlled vocabulary. EXAMPLE: public, regulatory submission
	Reference_source_id	The reference source identifier shall be specified.
	Reference_source_citation	The literature or regulatory document reference shall be referenced.

Data element level	Data element name	Data element description
gene		The gene section This section shall provide a description of the gene in relation to a substance, where applicable.
	Gene_sequence_origin	The common name for the organism from which the final gene sequence originated shall be specified; this applies primarily to proteins.
	Gene_id	The identifier of the gene shall be provided.
	Gene_name	The complete name given for a gene shall be provided.
reference_source		The reference source section This section described the reference sources of the information.
	Public_domain	It shall be specified if the reference source information is public or not. Yes or No values apply.
	Reference_source_type	The type of the reference source shall be specified based on a controlled vocabulary.
	Reference_source_class	The class of the reference source shall be specified based on a controlled vocabulary. EXAMPLE: public, regulatory submission
	Reference_source_id	The reference source identifier shall be specified.
	Reference_source_citation	The literature or regulatory document reference shall be referenced.
gene_element		The gene element section
	Gene_element_type	The type of the gene element shall be specified based on a controlled vocabulary. EXAMPLE: enhancer, promoter, silencer, terminator, repressor (..)
	Gene_element_id	The unique identifier for the gene element shall be specified based on a controlled vocabulary.

Data element level	Data element name	Data element description
	Gene_element_name	The specific gene element name shall be described based on a controlled vocabulary.
reference_source		<p>The reference source section</p> <p>This section described the reference sources of the information.</p>
	Public_domain	It shall be specified if the reference source information is public or not. Yes or No values apply.
	Reference_source_type	The type of the reference source shall be specified based on a controlled vocabulary.
	Reference_source_class	<p>The class of the reference source shall be specified based on a controlled vocabulary.</p> <p>EXAMPLE: public, regulatory submission</p>
	Reference_source_id	The reference source identifier shall be specified.
	Reference_source_citation	The literature or regulatory document reference shall be referenced.
target		<p>The target section</p> <p>This section shall provide information on the target substance.</p>
	Target_gene_id	The identifier of the target gene shall be provided.
	Target_gene_name	<p>The target gene name shall be specified based on a controlled vocabulary.</p> <p>EXAMPLE: single substance, a pathway, an enzyme type</p>
	Interaction_type	<p>The type of interaction shall be specified based on a controlled vocabulary.</p> <p>EXAMPLE: inhibitor, inducer</p>
	Target_organism_type	<p>The type of target organism shall be specified based on a controlled vocabulary.</p> <p>EXAMPLE: human, viral, bacteria, fungal</p>

Data element level	Data element name	Data element description
	Target_type	The target type shall be specified based on a controlled vocabulary. EXAMPLE: enzyme, receptor, membrane
reference_source		The reference source section This section described the reference sources of the information.
	Public_domain	It shall be specified if the reference source information is public or not. Yes or No values apply.
	Reference_source_type	The type of the reference source shall be specified based on a controlled vocabulary.
	Reference_source_class	The class of the reference source shall be specified based on a controlled vocabulary. EXAMPLE: public, regulatory submission
	Reference_source_id	The reference source identifier shall be specified.
	Reference_source_citation	The literature or regulatory document reference shall be referenced.
constituent		The constituent section The identifying characteristics of the constituent of the specified substance group 1 shall be specified.
	Substance_id	The substance or specified substance unique identifier of the substance constituting the specified substance group 1 shall be described.
	Substance_name	The name of the constituent substance shall be described.
	Substance_role	The role of the substance in the specified substance shall be described based on a controlled vocabulary. EXAMPLE: active marker, component, impurity, degradant, metabolite

Data element level	Data element name	Data element description
	Amount_type	The type of the amount based on a controlled vocabulary. EXAMPLE: mole ratio, weight percent
amount		The amount section
	Average	The average amount or single value of the substance shall be specified.
	Low_limit	The lower limit of the substance shall be specified, where available.
	High_limit	The higher limit of the substance shall be specified, where available.
	Unit	The applicable unit for the amount shall be specified.
	Non_numeric_value	The non numeric value shall be specified based on a controlled vocabulary.
property		The property section The characteristics of the property shall be described.
	Property_type	The type of property shall be specified based on a controlled vocabulary. EXAMPLE: physical, chemical, enzymatic, immunological
	Property_name	The name of property shall be specified.
	Substance_id	The identifier of the substance related to a defining property shall be described. EXAMPLE: for cell surface antigens, the substance id for cd4 would be captured to define cd4 positive cells
	Substance_name	The name of the substance related to a defining property shall be described. EXAMPLE: for cell surface antigens
	Amount_type	The type of the amount based on a controlled vocabulary shall be specified. EXAMPLE: mole ratio, weight percent

Data element level	Data element name	Data element description
amount		The amount section
	Average	The average amount or single value of the substance shall be specified.
	Low_limit	The lower limit of the substance shall be specified, where available.
	High_limit	The higher limit of the substance shall be specified, where available.
	Unit	The applicable unit for the amount shall be specified.
	Non_numeric_value	The non numeric value shall be specified based on a controlled vocabulary.
physical_form		The physical form section The characteristics of the physical form of the specified substance shall be described.
	Physical_state	The physical state shall be specified based on a controlled vocabulary. EXAMPLE: solid, liquid, gas, emulsion
	Physical_form_type	The physical form type shall be specified based on a controlled vocabulary. EXAMPLE: crystalline, amorphous, tincture, dry, extract
	Amount_type	The type of the amount based on a controlled vocabulary shall be specified. EXAMPLE: mole ratio, weight percent
amount		The amount section
	Average	The average amount or single value of the substance shall be specified.
	Low_limit	The lower limit of the substance shall be specified, where available.
	High_limit	The higher limit of the substance shall be specified, where available.
	Unit	The applicable unit for the amount shall be specified.
	Non_numeric_value	The non numeric value shall be specified based on a controlled vocabulary.

Data element level	Data element name	Data element description
reference_source		The reference source section This section described the reference sources of the information.
	Public_domain	It shall be specified if the reference source information is public or not. Yes or No values apply.
	Reference_source_type	The type of the reference source shall be specified based on a controlled vocabulary.
	Reference_source_class	The class of the reference source shall be specified based on a controlled vocabulary. EXAMPLE: public, regulatory submission
	Reference_source_id	The reference source identifier shall be specified.
	Reference_source_citation	The literature or regulatory document reference shall be referenced.

4.2.8. SSI for specified substance – group 2

For Specified Substance Group 2, the SSI shall be described based on the following data elements:

Data element level	Data element name	Data element description
specified_substance_group2		The specified substance group 2 section The identifying characteristics of the specified substance group 2 shall be described.
	Specified_substance_group2_id	The specified substance group 2 unique identifier shall be specified.
	Specified_substance_group2_name	The specified substance group 2 name shall be specified.
	Parent_substance_id	The ID of the parent shall be specified. The ID of the parent for the specified substance group 1 may refer to either a substance ID or a specified substance group 1 ID.

Data element level	Data element name	Data element description
manufacturing		The manufacturing section The main characteristics in relation to the manufacturing of the substance shall be specified.
	Manufacturer_id	The unique code used to track manufacturers shall be provided.
	Manufacturer_name	The name of the manufacturer of the specified substance shall be provided.
	Manufacturer_type	The type of the manufacturer shall be provided based on a controlled vocabulary.
	Production_method_type	The type of the production method shall be provided based on a controlled vocabulary. EXAMPLE: synthetic, extractive, semisynthetic, biosynthetic, etc
	Production_system_type	The type of the production system shall be provided based on a controlled vocabulary. EXAMPLE: cell line, animal, tissue, egg
	Production_system	The production system description shall be provided. EXAMPLE: cho cell, goat, bovine lungs
	Number_of_critical_processes	The number of critical processes shall be specified.
reference_source		The reference source section This section described the reference sources of the information.
	Public_domain	It shall be specified if the reference source information is public or not. Yes or No values apply.
	Reference_source_type	The type of the reference source shall be specified based on a controlled vocabulary.

Data element level	Data element name	Data element description
	Reference_source_class	The class of the reference source shall be specified based on a controlled vocabulary. EXAMPLE: public, regulatory submission
	Reference_source_id	The reference source identifier shall be specified.
	Reference_source_citation	The literature or regulatory document reference shall be referenced.
Substance		
	Substance ID	The unique identifier assigned to the substance.
substance_name		The substance name section This section contains the set of elements for the description of the name of the substance.
	Substance_name	The name of the substance shall be specified.
	Substance_name_type	The type of the name shall be specified based on a controlled vocabulary. EXAMPLE: code, brand name, established name, primary name, other name.
	Language	The language of the substance name shall be specified according to ISO 639-2 alpha-3 codes.
official_name		The official name section
	Official_name_type	The type of the official name shall be specified based on a controlled vocabulary. EXAMPLE: USAN, INN, JAN, BAN, USP, EP, INCI, JECFA
	Official_name_status	The status of the official name shall be specified based on a controlled vocabulary. EXAMPLE: current, alternate, superceded, proposed

Data element level	Data element name	Data element description
	Official_name_status_change_date	The change date of the status of the official name shall be specified in line with the ISO 8601 date format, which shall be only entered when name is changed.
official_name_domain		The official domain name section
	Official_name_domain	The domain of the name shall be provided based on a controlled vocabulary. EXAMPLE: biologic
official_name_jurisdiction		The jurisdiction of the official name section
	Official_name_jurisdiction	The jurisdiction of the official name shall be provided based on ISO 3166-1 alpha-2 codes with two exceptions: EL (not GR) is used to represent Greece, and UK (not GB) is used to represent the United Kingdom.
reference_source		The reference source section This section describes the reference source information.
	Public_domain	It shall be specified if the reference source information is public or not. Yes or No values apply.
	Reference_source_type	The type of the reference source shall be specified based on a controlled vocabulary. EXAMPLE: INN
	Reference_source_class	The class of the reference source shall be specified based on a controlled vocabulary. EXAMPLE: public, regulatory submission
	Reference_source_id	The reference source identifier shall be specified.
	Reference_source_citation	The literature or regulatory document reference shall be described.
substance_code		The substance code section This section describes the code system(s) that apply to a substance.

Data element level	Data element name	Data element description
	Code	The specific code with regard to a referenced code system shall be provided.
	Code_system	The code system shall be specified based on a controlled vocabulary EXAMPLE: CAS, EINECS, NSC, ASK, ATC, Ndf-Rt; Rx-Cui
	Code_system_id	The identifier for the code system shall be provided based on a controlled vocabulary.
	Code_system_status	The status of the code system shall be specified based on a controlled vocabulary. EXAMPLE: current, alternate, superceded.
	Code_system_change_date	The change date of the code system shall be specified in line with the ISO 8601 date format, where applicable. This shall be generated when the status changes.
	Comment	Any comment shall be provided in this field, if required.
reference_source		The reference source section This section described the reference sources of the information.
	Public_domain	It shall be specified if the reference source information is public or not. Yes or No values apply.
	Reference_source_type	The type of the reference source shall be specified based on a controlled vocabulary.
	Reference_source_class	The class of the reference source shall be specified based on a controlled vocabulary. EXAMPLE: public, regulatory submission
	Reference_source_id	The reference source identifier shall be specified.

Data element level	Data element name	Data element description
	Reference_source_citation	The literature or regulatory document reference shall be referenced.
version		The version section This section shall provide information on the version of the substance information.
	Version_number	The number of the version of the SSI shall be provided.
	Effective_date	The date when the SSI was effective shall be provided in line with the ISO 8601 date format. This shall be defined when the SSI is generated or modified.
	Change_made	The description of the updates or changes of the SSI shall be specified.
reference_information		The reference information section This section is used to provide details about the reference information.
	Comment	Additional information as regards the applicable references can be specified.
substance_classification		The substance classification
	Domain	The domain of the substance classification shall be provided based on a controlled vocabulary. EXAMPLE: vaccine, colorant, flavor
	Substance_classification	The substance classification shall be provided based on a controlled vocabulary. EXAMPLE: hmg-coeductase inhibitor
	Substance_classification_type	The type of the classification applied shall be provided based on a controlled vocabulary. EXAMPLE: WHO-ATC, NDF-RT
	Substance_classification_code	The code of the classification type shall be specified based on a controlled vocabulary. EXAMPLE: ATC code, NDF-RT code
subtype		The subtype section

Data element level	Data element name	Data element description
	Substance_class_subtype	The sub-type of the classification shall be described based on a controlled vocabulary. EXAMPLE: human, viral, bacteria, fungal
reference_source		The reference source section This section described the reference sources of the information.
	Public_domain	It shall be specified if the reference source information is public or not. Yes or No values apply.
	Reference_source_type	The type of the reference source shall be specified based on a controlled vocabulary.
	Reference_source_class	The class of the reference source shall be specified based on a controlled vocabulary. EXAMPLE: public, regulatory submission
	Reference_source_id	The reference source identifier shall be specified.
	Reference_source_citation	The literature or regulatory document reference shall be referenced.
substance_relationship		The substance relationship This section shall provide information related to relationship of a substance, where this is applicable.
	Relationship	The relationship of a substance shall be defined based on a controlled vocabulary. EXAMPLE: active moiety, constituent, impurity, degradant, may contain, metabolite, target, transporter, metabolic enzyme, gene element, etc
	Interaction_type	The type of interaction shall be specified based on a controlled vocabulary, where applicable. EXAMPLE: substrate, agonist, partial agonist, antagonist

Data element level	Data element name	Data element description
	Substance_id	The substance identifier, for which the relationship is specified, shall be described.
	Substance_name	The substance name shall be specified.
	Amount_type	The type of the amount of the substance shall be specified using a controlled vocabulary. EXAMPLE: mole ratio, weight percent
amount		The amount section
	Average	The average amount or single value of the substance shall be specified.
	Low_limit	The lower limit of the substance shall be specified, where available.
	High_limit	The higher limit of the substance shall be specified, where available.
	Unit	The applicable unit for the amount shall be specified.
	Non_numeric_value	The non numeric value shall be specified based on a controlled vocabulary.
reference_source		The reference source section This section described the reference sources of the information.
	Public_domain	It shall be specified if the reference source information is public or not. Yes or No values apply.
	Reference_source_type	The type of the reference source shall be specified based on a controlled vocabulary.
	Reference_source_class	The class of the reference source shall be specified based on a controlled vocabulary. EXAMPLE: public, regulatory submission
	Reference_source_id	The reference source identifier shall be specified.
	Reference_source_citation	The literature or regulatory document reference shall be referenced.

Data element level	Data element name	Data element description
gene		The gene section This section shall provide a description of the gene in relation to a substance, where applicable.
	Gene_sequence_origin	The common name for the organism from which the final gene sequence originated shall be specified; this applies primarily to proteins.
	Gene_id	The identifier of the gene shall be provided.
	Gene_name	The complete name given for a gene shall be provided.
reference_source		The reference source section This section described the reference sources of the information.
	Public_domain	It shall be specified if the reference source information is public or not. Yes or No values apply.
	Reference_source_type	The type of the reference source shall be specified based on a controlled vocabulary.
	Reference_source_class	The class of the reference source shall be specified based on a controlled vocabulary. EXAMPLE: public, regulatory submission
	Reference_source_id	The reference source identifier shall be specified.
	Reference_source_citation	The literature or regulatory document reference shall be referenced.
gene_element		The gene element section
	Gene_element_type	The type of the gene element shall be specified based on a controlled vocabulary. EXAMPLE: enhancer, promoter, silencer, terminator, repressor (..)
	Gene_element_id	The unique identifier for the gene element shall be specified based on a controlled vocabulary.

Data element level	Data element name	Data element description
	Gene_element_name	The specific gene element name shall be described based on a controlled vocabulary.
reference_source		<p>The reference source section</p> <p>This section described the reference sources of the information.</p>
	Public_domain	It shall be specified if the reference source information is public or not. Yes or No values apply.
	Reference_source_type	The type of the reference source shall be specified based on a controlled vocabulary.
	Reference_source_class	<p>The class of the reference source shall be specified based on a controlled vocabulary.</p> <p>EXAMPLE: public, regulatory submission</p>
	Reference_source_id	The reference source identifier shall be specified.
	Reference_source_citation	The literature or regulatory document reference shall be referenced.
target		<p>The target section</p> <p>This section shall provide information on the target substance.</p>
	Target_gene_id	The identifier of the target gene shall be provided.
	Target_gene_name	<p>The target gene name shall be specified based on a controlled vocabulary.</p> <p>EXAMPLE: single substance, a pathway, an enzyme type</p>
	Interaction_type	<p>The type of interaction shall be specified based on a controlled vocabulary.</p> <p>EXAMPLE: inhibitor, inducer</p>
	Target_organism_type	<p>The type of target organism shall be specified based on a controlled vocabulary.</p> <p>EXAMPLE: human, viral, bacteria, fungal</p>

Data element level	Data element name	Data element description
	Target_type	The target type shall be specified based on a controlled vocabulary. EXAMPLE: enzyme, receptor, membrane
reference_source		The reference source section This section described the reference sources of the information.
	Public_domain	It shall be specified if the reference source information is public or not. Yes or No values apply.
	Reference_source_type	The type of the reference source shall be specified based on a controlled vocabulary.
	Reference_source_class	The class of the reference source shall be specified based on a controlled vocabulary. EXAMPLE: public, regulatory submission
	Reference_source_id	The reference source identifier shall be specified.
	Reference_source_citation	The literature or regulatory document reference shall be referenced.

4.2.9. SSI for specified substance – group 3

For Specified Substance Group 3, the SSI shall be described based on the following data elements:

Data element level	Data element name	Data element description
specified_substance_group3		The specified substance group 3 section The identifying characteristics of the specified substancegroup 3 shall be specified.
	Specified_substance_group3_id	The specified substance unique identifier shall be specified.
	Specified_substance_group3_name	The specified substance name shall be specified.

Data element level	Data element name	Data element description
	Parent_substance_id	The ID of the parent shall be specified. The ID of the parent for specified substance group 3 may refer to either a substance ID and/or a specified substance ID of group 1 and/or group 2.
grade		The grade section The characteristics of the grade of the substance shall be specified.
	Grade_type	The type of the grade shall be provided based on a controlled vocabulary.
	Grade_name	The name of the grade as specified in the monograph shall be provided. EXAMPLE: purified water, water for injection
	Grade_reference_source	The specific reference to a monograph source shall be provided. EXAMPLE: USP 33 (USP, EP, ACS, Technical)
reference_source		The reference source section This section described the reference sources of the information.
	Public_domain	It shall be specified if the reference source information is public or not. Yes or No values apply.
	Reference_source_type	The type of the reference source shall be specified based on a controlled vocabulary.
	Reference_source_class	The class of the reference source shall be specified based on a controlled vocabulary. EXAMPLE: public, regulatory submission
	Reference_source_id	The reference source identifier shall be specified.
	Reference_source_citation	The literature or regulatory document reference shall be referenced.
Substance		

Data element level	Data element name	Data element description
	Substance ID	The unique identifier assigned to the substance.
substance_name		The substance name section This section contains the set of elements for the description of the name of the substance.
	Substance_name	The name of the substance shall be specified.
	Substance_name_type	The type of the name shall be specified based on a controlled vocabulary. EXAMPLE: code, brand name, established name, primary name, other name.
	Language	The language of the substance name shall be specified according to ISO 639-2 alpha-3 codes.
official_name		The official name section
	Official_name_type	The type of the official name shall be specified based on a controlled vocabulary. EXAMPLE: USAN, INN, JAN, BAN, USP, EP, INCI, JECFA
	Official_name_status	The status of the official name shall be specified based on a controlled vocabulary. EXAMPLE: current, alternate, superceded, proposed
	Official_name_status_change_date	The change date of the status of the official name shall be specified in line with the ISO 8601 date format, which shall be only entered when name is changed.
official_name_domain		The official domain name section
	Official_name_domain	The domain of the name shall be provided based on a controlled vocabulary. EXAMPLE: biologic
official_name_jurisdiction		The jurisdiction of the official name section

Data element level	Data element name	Data element description
	Official_name_jurisdiction	The jurisdiction of the official name shall be provided based on ISO 3166-1 alpha-2 codes with two exceptions: EL (not GR) is used to represent Greece, and UK (not GB) is used to represent the United Kingdom.
reference_source		<p>The reference source section</p> <p>This section describes the reference source information.</p>
	Public_domain	It shall be specified if the reference source information is public or not. Yes or No values apply.
	Reference_source_type	<p>The type of the reference source shall be specified based on a controlled vocabulary.</p> <p>EXAMPLE: INN</p>
	Reference_source_class	<p>The class of the reference source shall be specified based on a controlled vocabulary.</p> <p>EXAMPLE: public, regulatory submission</p>
	Reference_source_id	The reference source identifier shall be specified.
	Reference_source_citation	The literature or regulatory document reference shall be described.
substance_code		<p>The substance code section</p> <p>This section describes the code system(s) that apply to a substance.</p>
	Code	The specific code with regard to a referenced code system shall be provided.
	Code_system	<p>The code system shall be specified based on a controlled vocabulary</p> <p>EXAMPLE: CAS, EINECS, NSC, ASK, ATC, Ndf-Rt; Rx-Cui</p>
	Code_system_id	The identifier for the code system shall be provided based on a controlled vocabulary.

Data element level	Data element name	Data element description
	Code_system_status	The status of the code system shall be specified based on a controlled vocabulary. EXAMPLE: current, alternate, superceded.
	Code_system_change_date	The change date of the code system shall be specified in line with the ISO 8601 date format, where applicable. This shall be generated when the status changes.
	Comment	Any comment shall be provided in this field, if required.
reference_source		The reference source section This section described the reference sources of the information.
	Public_domain	It shall be specified if the reference source information is public or not. Yes or No values apply.
	Reference_source_type	The type of the reference source shall be specified based on a controlled vocabulary.
	Reference_source_class	The class of the reference source shall be specified based on a controlled vocabulary. EXAMPLE: public, regulatory submission
	Reference_source_id	The reference source identifier shall be specified.
	Reference_source_citation	The literature or regulatory document reference shall be referenced.
version		The version section This section shall provide information on the version of the substance information.
	Version_number	The number of the version of the SSI shall be provided.

Data element level	Data element name	Data element description
	Effective_date	The date when the SSI was effective shall be provided in line with the ISO 8601 date format. This shall be defined when the SSI is generated or modified.
	Change_made	The description of the updates or changes of the SSI shall be specified.
reference_information		The reference information section This section is used to provide details about the reference information.
	Comment	Additional information as regards the applicable references can be specified.
substance_classification		The substance classification
	Domain	The domain of the substance classification shall be provided based on a controlled vocabulary. EXAMPLE: vaccine, colorant, flavor
	Substance_classification	The substance classification shall be provided based on a controlled vocabulary. EXAMPLE: hmg-coreductase inhibitor
	Substance_classification_type	The type of the classification applied shall be provided based on a controlled vocabulary. EXAMPLE: WHO-ATC, NDF-RT
	Substance_classification_code	The code of the classification type shall be specified based on a controlled vocabulary. EXAMPLE: ATC code, NDF-RT code
subtype		The subtype section
	Substance_class_subtype	The sub-type of the classification shall be described based on a controlled vocabulary. EXAMPLE: human, viral, bacteria, fungal
reference_source		The reference source section This section described the reference sources of the information.

Data element level	Data element name	Data element description
	Public_domain	It shall be specified if the reference source information is public or not. Yes or No values apply.
	Reference_source_type	The type of the reference source shall be specified based on a controlled vocabulary.
	Reference_source_class	The class of the reference source shall be specified based on a controlled vocabulary. EXAMPLE: public, regulatory submission
	Reference_source_id	The reference source identifier shall be specified.
	Reference_source_citation	The literature or regulatory document reference shall be referenced.
substance_relationship		The substance relationship This section shall provide information related to relationship of a substance, where this is applicable.
	Relationship	The relationship of a substance shall be defined based on a controlled vocabulary. EXAMPLE: active moiety, constituent, impurity, degradant, may contain, metabolite, target, transporter, metabolic enzyme, gene element, etc
	Interaction_type	The type of interaction shall be specified based on a controlled vocabulary, where applicable. EXAMPLE: substrate, agonist, partial agonist, antagonist
	Substance_id	The substance identifier, for which the relationship is specified, shall be described.
	Substance_name	The substance name shall be specified.
	Amount_type	The type of the amount of the substance shall be specified using a controlled vocabulary. EXAMPLE: mole ratio, weight percent

Data element level	Data element name	Data element description
amount		The amount section
	Average	The average amount or single value of the substance shall be specified.
	Low_limit	The lower limit of the substance shall be specified, where available.
	High_limit	The higher limit of the substance shall be specified, where available.
	Unit	The applicable unit for the amount shall be specified.
	Non_numeric_value	The non numeric value shall be specified based on a controlled vocabulary.
reference_source		The reference source section This section described the reference sources of the information.
	Public_domain	It shall be specified if the reference source information is public or not. Yes or No values apply.
	Reference_source_type	The type of the reference source shall be specified based on a controlled vocabulary.
	Reference_source_class	The class of the reference source shall be specified based on a controlled vocabulary. EXAMPLE: public, regulatory submission
	Reference_source_id	The reference source identifier shall be specified.
	Reference_source_citation	The literature or regulatory document reference shall be referenced.
gene		The gene section This section shall provide a description of the gene in relation to a substance, where applicable.
	Gene_sequence_origin	The common name for the organism from which the final gene sequence originated shall be specified; this applies primarily to proteins.

Data element level	Data element name	Data element description
	Gene_id	The identifier of the gene shall be provided.
	Gene_name	The complete name given for a gene shall be provided.
reference_source		The reference source section This section described the reference sources of the information.
	Public_domain	It shall be specified if the reference source information is public or not. Yes or No values apply.
	Reference_source_type	The type of the reference source shall be specified based on a controlled vocabulary.
	Reference_source_class	The class of the reference source shall be specified based on a controlled vocabulary. EXAMPLE: public, regulatory submission
	Reference_source_id	The reference source identifier shall be specified.
	Reference_source_citation	The literature or regulatory document reference shall be referenced.
gene_element		The gene element section
	Gene_element_type	The type of the gene element shall be specified based on a controlled vocabulary. EXAMPLE: enhancer, promoter, silencer, terminator, repressor (..)
	Gene_element_id	The unique identifier for the gene element shall be specified based on a controlled vocabulary.
	Gene_element_name	The specific gene element name shall be described based on a controlled vocabulary.
reference_source		The reference source section This section described the reference sources of the information.

Data element level	Data element name	Data element description
	Public_domain	It shall be specified if the reference source information is public or not. Yes or No values apply.
	Reference_source_type	The type of the reference source shall be specified based on a controlled vocabulary.
	Reference_source_class	The class of the reference source shall be specified based on a controlled vocabulary. EXAMPLE: public, regulatory submission
	Reference_source_id	The reference source identifier shall be specified.
	Reference_source_citation	The literature or regulatory document reference shall be referenced.
target		The target section This section shall provide information on the target substance.
	Target_gene_id	The identifier of the target gene shall be provided.
	Target_gene_name	The target gene name shall be specified based on a controlled vocabulary. EXAMPLE: single substance, a pathway, an enzyme type
	Interaction_type	The type of interaction shall be specified based on a controlled vocabulary. EXAMPLE: inhibitor, inducer
	Target_organism_type	The type of target organism shall be specified based on a controlled vocabulary. EXAMPLE: human, viral, bacteria, fungal
	Target_type	The target type shall be specified based on a controlled vocabulary. EXAMPLE: enzyme, receptor, membrane
reference_source		The reference source section This section described the reference sources of the information.

Data element level	Data element name	Data element description
	Public_domain	It shall be specified if the reference source information is public or not. Yes or No values apply.
	Reference_source_type	The type of the reference source shall be specified based on a controlled vocabulary.
	Reference_source_class	The class of the reference source shall be specified based on a controlled vocabulary. EXAMPLE: public, regulatory submission
	Reference_source_id	The reference source identifier shall be specified.
	Reference_source_citation	The literature or regulatory document reference shall be referenced.

5. EV Product Report Message Acknowledgement Message

5.1. Acknowledgement Message (EVPRM_ACK)

Upon receipt of an EVPRM the Agency will generate an Acknowledgement Message (EVPRM_ACK). This EVPRM_ACK contains the result for each report operation type specified in the EVPRM. If errors are present in the EVPRM, the EVPRM_ACK will also report the description of each error identified.

5.2. Acknowledgement structure

The EVPRM_ACK contains two levels of acknowledgements:

The first level is the Message Acknowledgement (*messageacknowledgement - Section A*). This level summarises the results of the electronic submission of medicinal product information via the EVPRM. The possible results at this level are:

- a) All medicinal product reports (medicinal product entries) loaded into the database:

All the reports contained in the EVPRM have been processed successfully.
- b) EVPRM Error, not all information processed successfully

Some reports contained in the EVPRM have not been processed successfully. The errors are listed in the reportacknowledgement section (Section B of the EVPRM_ACK).
- c) XML parsing error, no data extracted

The parser could not read and process the EVPRM received due to some errors of the XML file.

The second level is the Report Acknowledgement (*reportacknowledgement* (Section B)). This level summarises the result of the operation type requested for each medicinal product entry in an EVPRM. This section also contains the mapping between the “local number” and the “EV Code” for those product entries that have been loaded successfully.

For the medicinal product entries that are not loaded successfully, the section *reportcomments* contains the list of errors encountered during the loading process.

The figures and data elements presented in this chapter are for illustration purposes.

Details on the mandatory sections and elements as well as the business rules applicable for each element will be addressed as part of the EVPRM_ACK XML Schema Definition Language (XSD) and technical instructions.

In the figures below the *mandatory sections/data elements* are presented as boxes with *solid lines* (as the message header) and the *non-mandatory sections/data elements* as boxes with *dotted lines* (as the Message Header).

The EVPRM acknowledgment XML schema is presented in Figure 29 - EVPRM Acknowledgement.

5.2.1. General structure

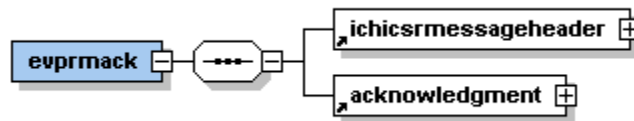

Figure 29 - EVPRM Acknowledgement

5.2.2. Acknowledgement message header

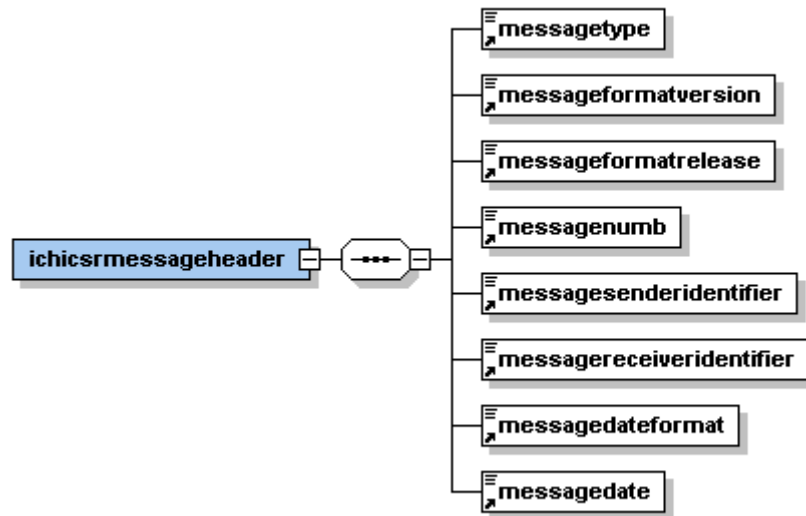

Figure 30 - EVPRM Acknowledgement - Message Header

5.2.3. Acknowledgment sections

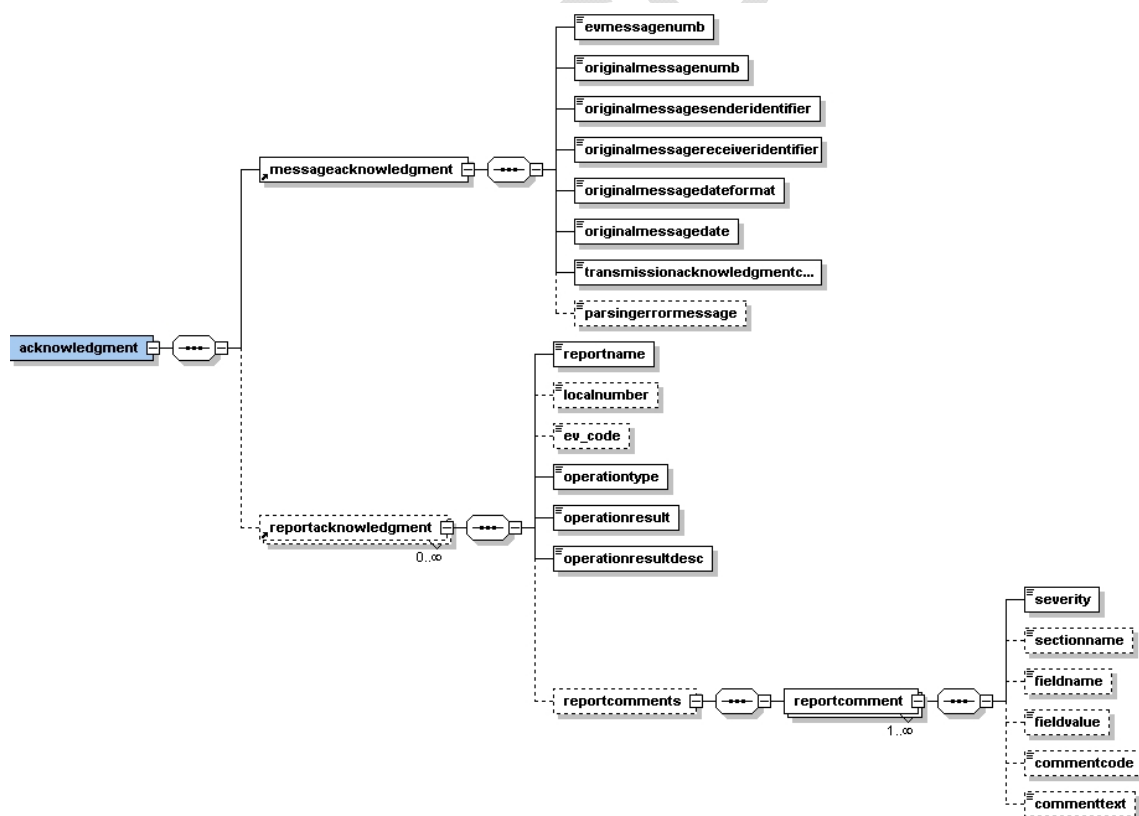

Figure 31 - EVPRM Acknowledgement - Acknowledgement Section

5.3. EVPRM Acknowledgement elements description

The EVPRM_ACK data elements are presented below with a reference to mandatory elements and the cardinalities of each element.

- **Mandatory:**

- Yes: indicates that the data element is mandatory.
- No: indicates that the data element is not mandatory.

- **Cardinality:**

The cardinality indicates the number of occurrences of the data elements.

- 0:1: optional data element with up to one occurrence
- 0:N: optional data element with one or more occurrence
- 1:1: mandatory data element with only one occurrence
- 1:N: mandatory data element with one or more occurrence

Data element reference	Data element name	Type	Cardinality	Data element description
A	evprmack See chapter 5.2.1.		YES	
B	ichicsrmessageheader See chapter 5.2.2.		YES	The message header section It refers to the Sender Organisation, the Receiver Organisation, the type of information being transmitted and the transmission date. This section requires the establishments of an EDI trading partnership agreement that will help define the message number, sender ID, receiver ID and message date.
B.1	messagetype	xs:string (16)	Yes	The message type contains information on the type of information being transmitted. The value of this field shall be "EVPRMACK".
B.2	messageformatversion	xs:string (3)	01:01	The message format version contains the version number of the schema.
B.3	messageformatrelease	xs:string (3)	01:01	The message format release contains the release number of the message format version of the schema.

Data element reference	Data element name	Type	Cardinality	Data element description
B.4	messagenumb	xs:string (100)	01:01	The message number is a unique tracking number assigned to a specific EVPRM transmitted by the sender organisation. This message number is unique to the sender organisation.
B.5	messagesenderidentifier	xs:string (60)	01:01	The message sender identifier uniquely identifies the sender of the EVPRM, e.g. company name identifier or regulatory authority name identifier.
B.6	messagereceiveridentifier	xs:string (60)	01:01	The message receiver identifier uniquely identifies the receiver of the EVPRM, e.g. company name identifier or regulatory authority name identifier.
B.7	messagedateformat	xs:string (3)	01:01	The original message date: The unique value admitted is "204" corresponding to "CCYYMMDDHHMMSS"
B.8	messagedate	xs:string (14)	01:01	Message Date: the message date on which the EVPRM was initiated.
E	messageacknowledgment See chapter 5.2.3.		Yes	The message acknowledgment section
E.1	evmessagenumb	xs:string (100)	Yes	The message number assigned to the EVPRM that the acknowledgement message refers to.
E.2	originalmessagenumb	xs:string (100)	Yes	The message number specified by the sender organisation in the EVPRM to which the acknowledgement message refers to.
E.4	originalmessagesenderidentifier	xs:string (60)	Yes	The message sender identifier specified by the sender organisation in the EVPRM to which the acknowledgement message refers to.
E.5	originalmessagereceiveridentifier	xs:string (60)	Yes	The message receiver identifier specified by the sender organisation in the EVPRM to which the acknowledgement message refers to.

Data element reference	Data element name	Type	Cardinality	Data element description
E.6	originalmessagedateformat	xs:string (3)	Yes	The message date format specified by the sender organisation in the EVPRM to which the acknowledgement message refers to.
E.7	originalmessagedate	xs:string (14)	Yes	The message date specified by the sender organisation in the EVPRM to which the acknowledgement message refers to.
E.8	transmissionacknowledgmentcode	Xs:string (2)	Yes	The general acknowledgement for the EVPRM: 01= All reports (medicinal product entries) loaded into database 02 = EVPRM Error, not all reports loaded into the database, check section B 03= SGML parsing error, no data extracted
E.9	parsingerrormessage	xs:string (250)	No	This data element contains the description of the problem when an error has occurred during the EVPRM parsing process. The data element is mandatory when the transmission acknowledgment code is 03.
G	reportacknowledgment		0:N	The report (medicinal product entry) acknowledgement This section contains information the acknowledgment for each report attached to the EVPRM.
G.1	reportname	xs:string (60)	Yes	This data element refers to the report section of the EVPRM.
G.2	localnumber	xs:string (60)	No	This data element reflects the local number assigned by the sender organisation to identify the report in the XML file. The local number may be Null for all operation types other than 'Insert' and is mandatory for the operation type 'Insert'.
G.3	Ev_code	xs:string (60)	No	The reference to the EV_CODE assigned by the EVMPD. May be Null if the operation type 'Insert' is unsuccessful.

Data element reference	Data element name	Type	Cardinality	Data element description
G.4	operationtype	xs:nonNegativeInteger value<7	Yes	This data element refers to the Operation Type requested 1 = Insert 2 = Update 3 = Variation 4 = Nullify 5 = Change Ownership 6 = Withdrawn
G.5	operationresult	xs:nonNegativeInteger	Yes	The outcome of the Operation for a particular section is referenced.
G.6	operationresultdesc	xs:string (240)	Yes	The description of the outcome of the operation.
G.7	reportcomments		No	The report comment section This section contains the list of errors and warnings detected during the parsing process of each report (medicinal product entry) contained in the EVPRM.
G.7.1	reportcomment		Yes	The parsing process will add a specific report comment for each parsing warning or error detected during the validation process.
G.7.1.1	severity	xs:nonNegativeInteger	Yes	The severity flag describes if the report comment is an error or a warning.
G.7.1.2	sectionname	xs:string (60)	No	The EVPRM section reference to which the comment is referring.
G.7.1.3	fieldname	xs:string (60)	No	This data element contains the field name(s) in which the first error was detected.
G.7.1.4	fieldvalue	xs:string (1000)	No	This data element contains the field value of the data element in which the first error was detected.
G.7.1.5	commentcode	xs:nonNegativeInteger (3)	No	This data element contains a comment about the error type.
G.7.1.6	commenttext	xs:string (1000)	No	This data element contains a detailed explanation of the detected error.
G.7.1.2	sectionname	xs:string (60)	No	The EVPRM section to which the comment is referring.

Data element reference	Data element name	Type	Cardinality	Data element description
G.7.1.3	fieldname	xs:string (60)	No	This data element contains the field name(s) in which the first error was detected.
G.7.1.4	fieldvalue	xs:string (1000)	No	This data element contains the field value of the data element in which the first error was detected.

6. Annex: Definitions

- Chemical refers to a type of substance defined by a single molecular structure that is not a protein or nucleic acid substance.

NOTE: Chemical substances are generally considered “small” molecules which have associated salts, solvates or ions and may be described using a single definitive or representative structure.

- Component refers to an intended constituent of a specified substance.

EXAMPLE: Dimethicone and silicon dioxide are components of simethicone. Human Insulin protamine and zinc are the components in Human Insulin Isophane.

NOTE: Components are used to describe the substances and specified substances that form a multi-substance material.

- Constituent refers to a substance or specified substance present within a specified substance.

NOTE: Constituents can be impurities, degradants, active marker or signature substances, or single substances mixed together to form a product. Constituents shall have an associated role and amount. Constituent specifications shall be used to describe components as well as limits on impurities or related substances for a given material.

- Controlled vocabulary refers to a finite set of values that represent the only allowed values for a data item.

NOTE: The allowed values can be codes, text, or numeric.

- Fraction refers to a distinct portion of material derived from a complex matrix, the composition of which differs from antecedent material.

EXAMPLE: Sera to Immunoglobulins to polyclonal IgG is an example of recursive fractionation.

NOTE: Concept used to describe source material. Concept is recursive in that a subsequent fraction can be derived from an antecedent fraction, which is implied in the order of listing.

- Grade refers to a set of specifications indicating the quality of a specified substance.
- Manufacturing refers to the process of production for a substance or medicinal product from the acquisition of all materials through all processing stages.
- Material refers to any entity that has mass, occupies space and consists of one or more substances.
- Mixture Substance is a type of polydisperse substance that is a combination of single substances isolated together or produced in the same synthetic process. Single substances of diverse origin that are brought together and do not undergo a chemical transformation shall be defined as multi-substance materials (Group 1 specified substances) and not as mixture substances.

EXAMPLE: Gentamicin would be defined as a mixture substance of Gentamicin C1A, Gentamicin C1, and Gentamicin C2. Glyceryl monoesters could be defined as a mixture substance of two single substances which differ in the position of esterification. Simethicone which consists of dimethicone and silicon dioxide would not be defined as a mixture substance since these are diverse materials brought together to form a product.

- Moiety refers to an entity within a substance that has a complete and continuous molecular structure. Moiety in this document may also be used to represent modification to a given substance.

EXAMPLE: The strength of a medicinal product is often based on what is referred to as the active moiety and should be defined in a consistent manner across all products. To avoid ambiguity the free acid and/or free base should be used as the moiety upon which strength is based.

NOTE: Within this document, moiety shall be used in the context of non-stoichiometric chemical substances and in modification of nucleic acid, proteins, polymers and structurally diverse substances. Moieties shall be single substances, ions, or solvate molecules.

- Molecular Fragment refers to the portion of a molecule that has one or more sites of attachment to other fragments or moieties.

NOTE: Molecular fragments will be used in the description of polymers to represent substituents and structural modifications to a given substance.

- Molecular Structure refers to the unambiguous representation of the arrangement of atoms. For the purposes of defining substances, the three dimensional conformations shall not be captured. Individual conformations or conformers of substances would only be captured in either a general sense for proteins (i.e. denatured) or when a given rotation about a single bond is restricted in such a way that the two different conformers are isolatable from each other and do not interconvert at room temperature (i.e. substituted biphenyls).

NOTE: This representation should be generally translatable into a graphical representation.

- Molecular Weight refers to the mass of one molecule of a homogenous substance or the average mass of molecules that comprise a heterogeneous substance. The unified atomic mass unit is the unit of molecular weight. The type of molecular weight should always be captured.

NOTE: For polymers there are several different types of molecular weight (weight average, number average).

- Multi-Substance Material refers to multiple substances and/or specified substances of diverse origin used as a component in the formulation of a medicinal product.

EXAMPLE: Materials such as Human Insulin Isophane, Simethicone (Simeticone), Aluminum Lakes, Nicotine Polacrilex, and Phosphate Buffered Saline are all multi-substance ingredients.

NOTE: Multi-substance materials are Group 1 specified substances. Any medicinal product used to formulate another medicinal product could also be considered a multi-substance material.

- Nucleic Acid Substance refers to the type of substance that can be defined by a linear sequence of nucleosides typically linked through phosphate esters.

NOTE: The type of nucleic acid substance (RNA, DNA) shall also be identified. Oligonucleotides and gene elements (i.e. promoters, enhancers, coding sequences, and silencers) shall be defined as nucleic acid substances.

- Official name refers to the name given by an official registration authority.
- Pharmaceutical Product refers to the qualitative and quantitative composition of a medicinal product in the dose form approved for administration in line with the regulated product information.

NOTE 1: A medicinal product may contain one or more pharmaceutical products.

NOTE 2: In many instances the pharmaceutical product is equal to the manufactured item. However, there are instances where the manufactured item must undergo a transformation before being administered to the patient (as the pharmaceutical product) and the two are not equal.

- Polydisperse Substance refers to a substance containing multiple related molecular components.

NOTE: Chemical substance salts and solvates shall not be defined as polydisperse substances.

- Polymer refers to the type of polydisperse substance that contains structural repeating units linked by covalent bonds.

NOTE: Monodisperse proteins and nucleic acids with defined sequences shall not be defined using the polymer substance elements.

- Protein refers to the type of substance with a defined sequence of alpha-amino-acids connected through peptide bonds.

NOTE 1: Synthetic peptides and proteins with defined sequences, recombinant proteins and highly purified proteins extracted from biological matrices shall be described as protein substances. Sites of glycosylation, disulfide linkages and glycosylation type (e.g. fungal, plant, arthropod, avian, mammalian, human) shall be defining elements of protein substances when known. A graphical molecular structure shall also be included in the definition of all peptides of 15 amino acid residues or less.

NOTE 2: Protein substance may refer to one of the following type: Vaccine or Other

- Salt refers to an ionic substances formed from the neutralization reaction of an acid and base. Salts are ionic compounds composed of cations (positive ions) and anions (negative ions).
- Single Substance refers to a substance that can be described by a single representation or set of descriptive elements. A single substance can be described

using one or more of five types of elements; chemical, protein, nucleic acid, polymer and structurally diverse substances.

NOTE: Racemates and substances with unknown, epimeric or mixed chirality can be defined as single substances because a single structural representation may be generated and the stereochemistry indicated as descriptive text.

- Specified Substance refers to groups of elements which describe multi-substance materials and specify further information on substances and multi-substance materials relevant to the description of medicinal products.

NOTE 1: For example, this could include grade, units of measure, physical form, constituents, manufacturer, critical manufacturing processes (i.e. extraction, synthetic, recombinant processes), specification and the analytical methods used to determine that a substance is in compliance with a specification.

NOTE 2: There are four different groups of elements that can be used to define a given specified substance and specific relationships between each group of elements.

- Specified Substance – Group 1 refers to material that contains multiple substances, solvents used in the preparation of herbal or allergenic extracts, specific marker or signature substances present in materials derived from biological matrices, the physical form of a substance when relevant and any properties essential to the description of the material.

Specified Substance Level 1 includes constituents, physical form and property. Constituents consist of intended substances added to create a multi-substance material, solvents used in the preparation of extracts, marker or signature substances present in animal derived material.

Impurities or degradants shall not be constituents for Group 1 specified substances.

NOTE 1: This grouping of constituents allows for the definitions of many materials in commerce that are used in the formulation of medicinal products.

- Specified Substance – Group 2 refers to the manufacturer of either a substance or a specified substance Group 1, along with minimal manufacturing information.

The minimal manufacturing information shall include the overall production method type (e.g. synthetic, extractive, recombinant) production system type (e.g. cell line, plant or animal tissue), production system (specific cell line).

NOTE: Group 2 elements would allow the tracking of the substance to the manufacturer. This is important for substances in biosimilar or other generic products. It also allows the distinguishing of synthetic peptides from recombinant peptides and the capture of the product cell line.

- Specified Substance – Group 3 refers to the grade of the material along with the source that defines the given grade.

Group 3 elements shall be used to distinguish specific pharmacopoeial and technical grades of material.

If the pharmacopoeial monographs related to a substance are not harmonized, the grade for each pharmacopeia shall be a separate Group 3 specified substance.

NOTE: For most active pharmaceutical substances, typical grades are USP, EP, or JP. For herbal substances the grades would be standardized, quantified and unstandardized.

EXAMPLE: For the substance *Water*, the Group 3 specified substance shall be *Sterile Water for Injection USP*.

- Stoichiometric refers to substances that contain moieties in simple integral ratios.

NOTE 1: Defined composition stoichiometry shall be represented in the structural representation of a given substance. Moieties shall be represented using the lowest common factors such that a fractional representation is avoided. Substances will either be defined as stoichiometric or non-stoichiometric.

NOTE 2: Chemicals have defined composition stoichiometry when the ratio of all moieties, (ion, counter ion and solvate) can be represented as simple integral ratios.

- Stereochemistry refers to relative spatial arrangement of atoms within molecules.
- Structurally Diverse Substance refers to a type of polydisperse substance isolated from a single source that is a complex mixture which cannot be described as a mixture of a limited number of single substances.

NOTE 1: Structurally diverse substances are defined based on immutable properties of a given material. Modifications that irreversibly alter the structure of the material, distinctive physical properties or components subsumed into the material, e.g. a gene in gene therapy substances are defining elements for structurally diverse substance. Fractions derived from source material (oils and juices) are also captured in the definition. Protein mixtures containing a large number of diverse sequences such as polyclonal immunoglobulins shall be defined as structurally diverse substances.

NOTE 2: Structurally Diverse Substance may refer to one of the following type

- Vaccine
 - Immunoglobulin
 - Blood derived
 - Herbal
 - Allergen
 - Cell therapy
 - Other
- Substance refers to any matter of defined composition that has discrete existence, whose origin may be biological, mineral or chemical.

NOTE 1: Substances can be single substances, mixture substances or one of a group of specified substances. Single substances shall be defined using a minimally sufficient set of data elements divided into five types; chemical, protein, nucleic acid, polymer,

and structurally diverse. Substances may be salts, solvates, free acids, free bases or mixtures of related compounds that are either isolated or synthesized together. Pharmacopeial terminology and defining characteristics will be used when available and appropriate. Defining elements are dependent on the type of substance.

NOTE 2: Discrete existence refers to the ability of a substance to exist independently of any other substance. Substances can either be well-defined entities containing definite chemical structures, synthetic (i.e. isomeric mixtures) or naturally-occurring (i.e. conjugated estrogens) mixtures of chemicals containing definite molecular structures, or materials derived from plants, animals, microorganisms or inorganic matrices for which the chemical structure may be unknown or difficult to define. Substances may be salts, solvates, free acids, free bases, mixtures of related compounds that are either isolated or synthesized together.

- Substituent refers to the molecular fragment attached to a structural repeat unit of a polymer that typically replaces a hydrogen atom.

NOTE: This information shall be captured as part of the structural repeat unit when the position of substitution is fully occupied. When occupancy of a site is incomplete, the amount of a substituent or substituents shall be specified as either a fragment or moiety structural modification.